



GRAFFIO®

Catalogo  
*Catalog Catalogue*

02

---

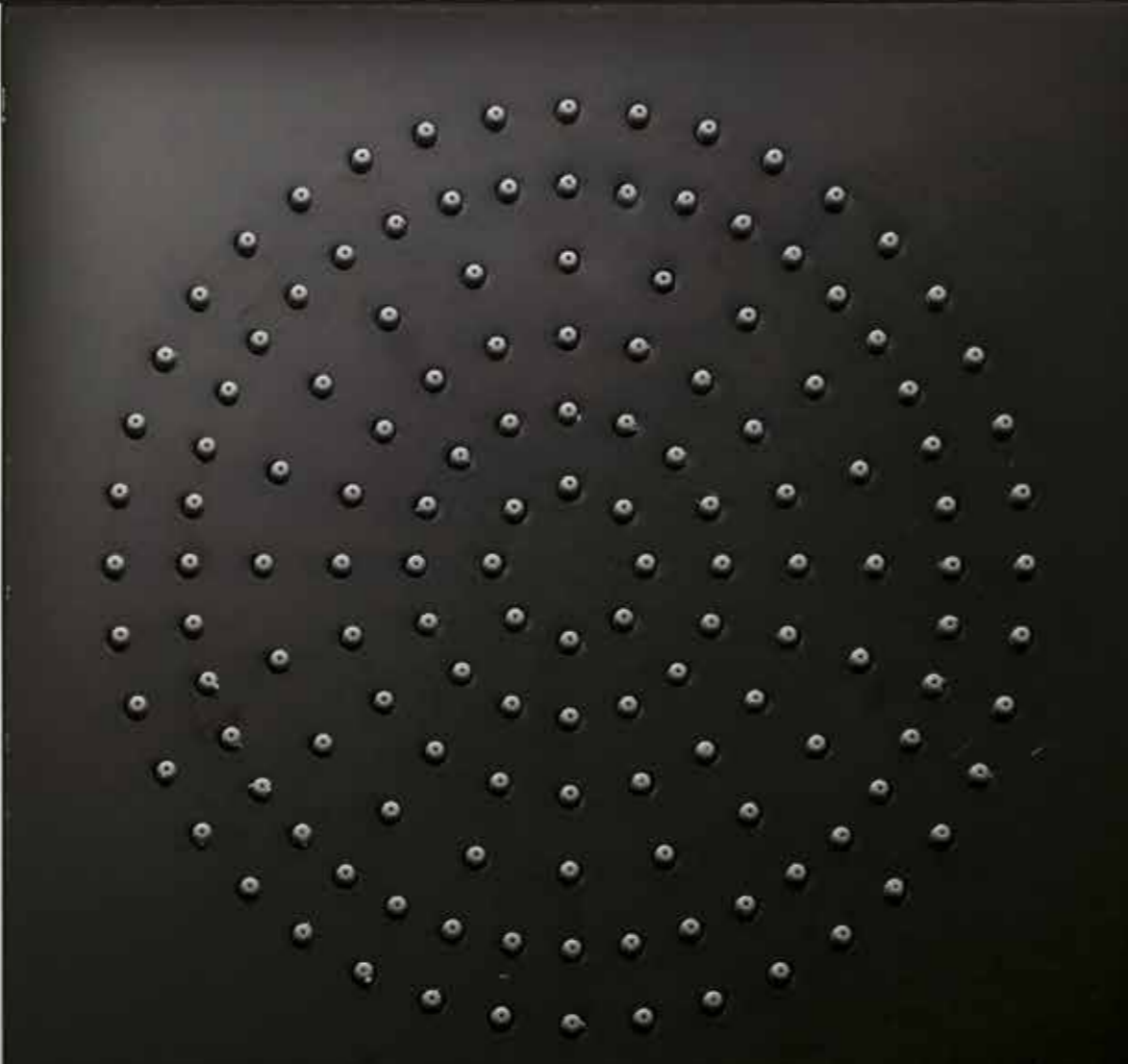
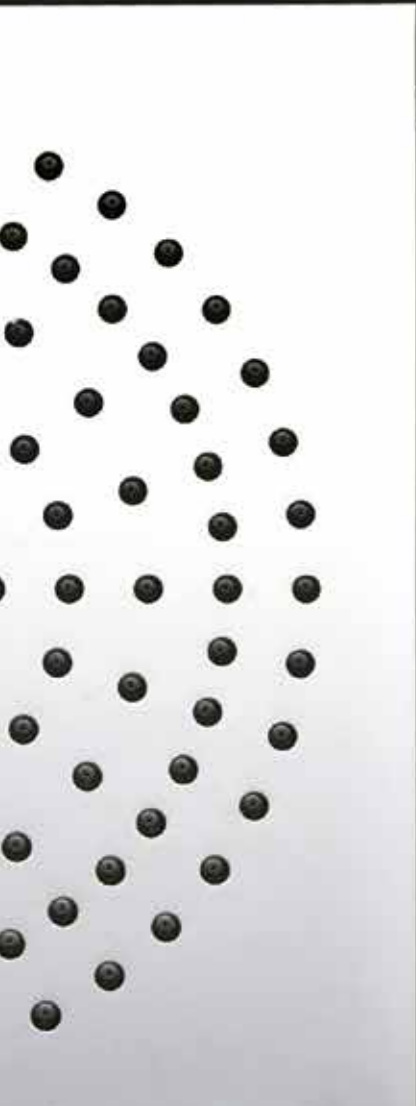
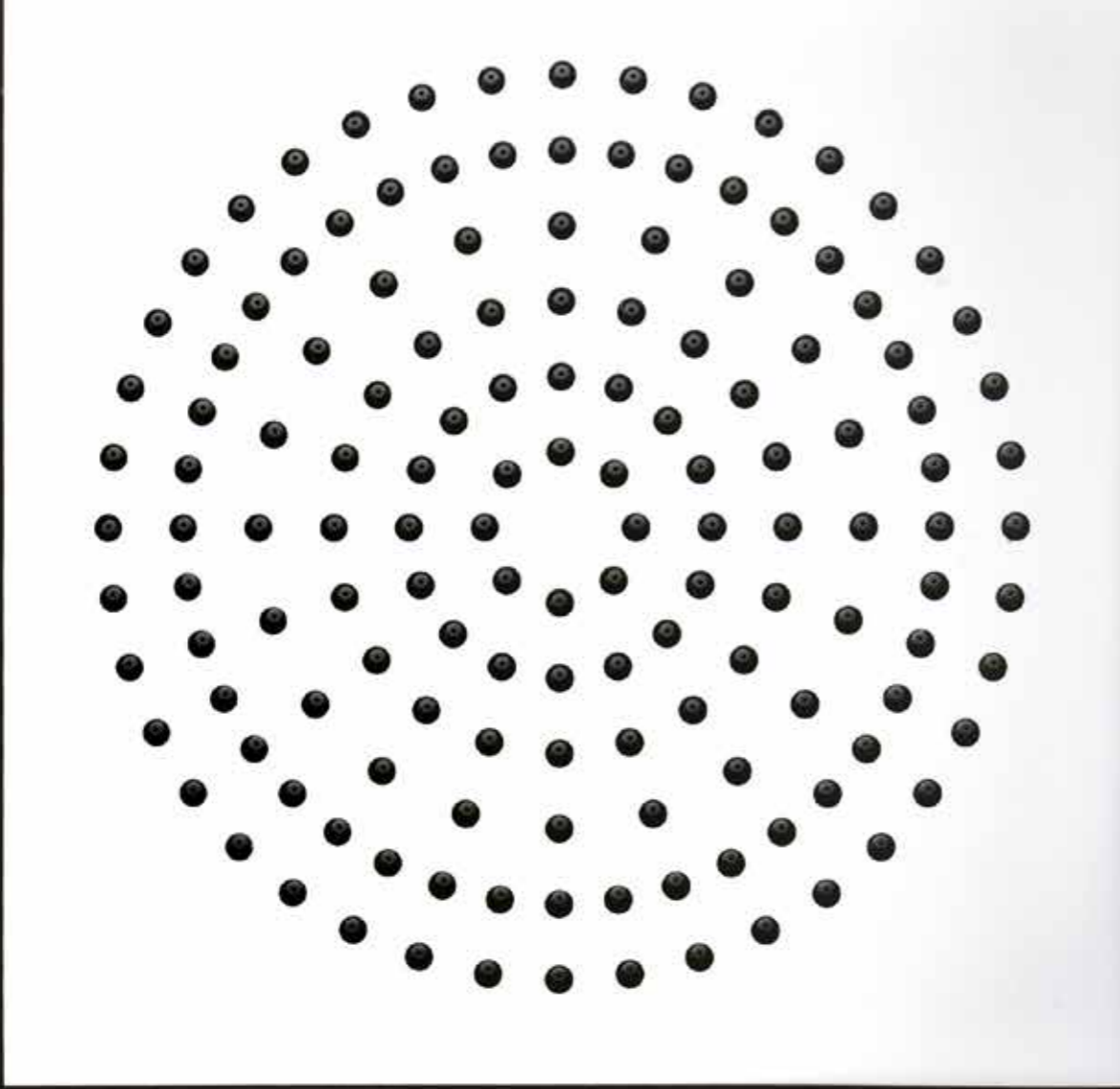

**Grafico**<sup>®</sup>  
Sign and design  
your lifestyle

GRAFFIO  
è la filosofia del sapere fare bene:  
imparare dalla natura per trovare forme nuove,  
usare l'ingegno e la manualità per reinventare il quotidiano.  
Nascono così collezioni uniche, dal carattere forte,  
realizzate in Italia e cosmopolite per vocazione.

*GRAFFIO*  
*embodies the philosophy of Know How in the best way:*  
*learning from Nature to capture new shapes*  
*and using art and dexterity to improve everyday life.*  
*Our unique collections have a strong character,*  
*are made in Italy and are Cosmopolitan by calling.*

*GRAFFIO*  
*représente la philosophie du savoir-faire au mieux:*  
*apprendre de la nature pour trouver nouvelles formes,*  
*profiter de l'ingéniosité et de l'habileté manuelle*  
*pour réinventer le quotidien.*  
*C'est comme ça qui naissent collections uniques,*  
*ayant un fort caractère, fabriquées en Italie*  
*et cosmopolites pour vocation.*

TU-YO	13
CIRANÒ	27
LAGUNA	33
FRAME	41
ARABESQUE	47
SKIN	55
MOND-RAIN	63
GIPZY	69
ONE WAY	77
CROMOTERAPIA	81
KINGS	89
STREET	95
CRYSTAL	99
ALLUMINIO	103
AMBIENTI	115
COLONNE DOCCIA	123
SALISCENDI	131
BODY JET	137
TERMOSTATICI	143
DOCCE IGIENICHE	147
IPERSCOPINI	159
HOOK	165

# GRAFFIO®

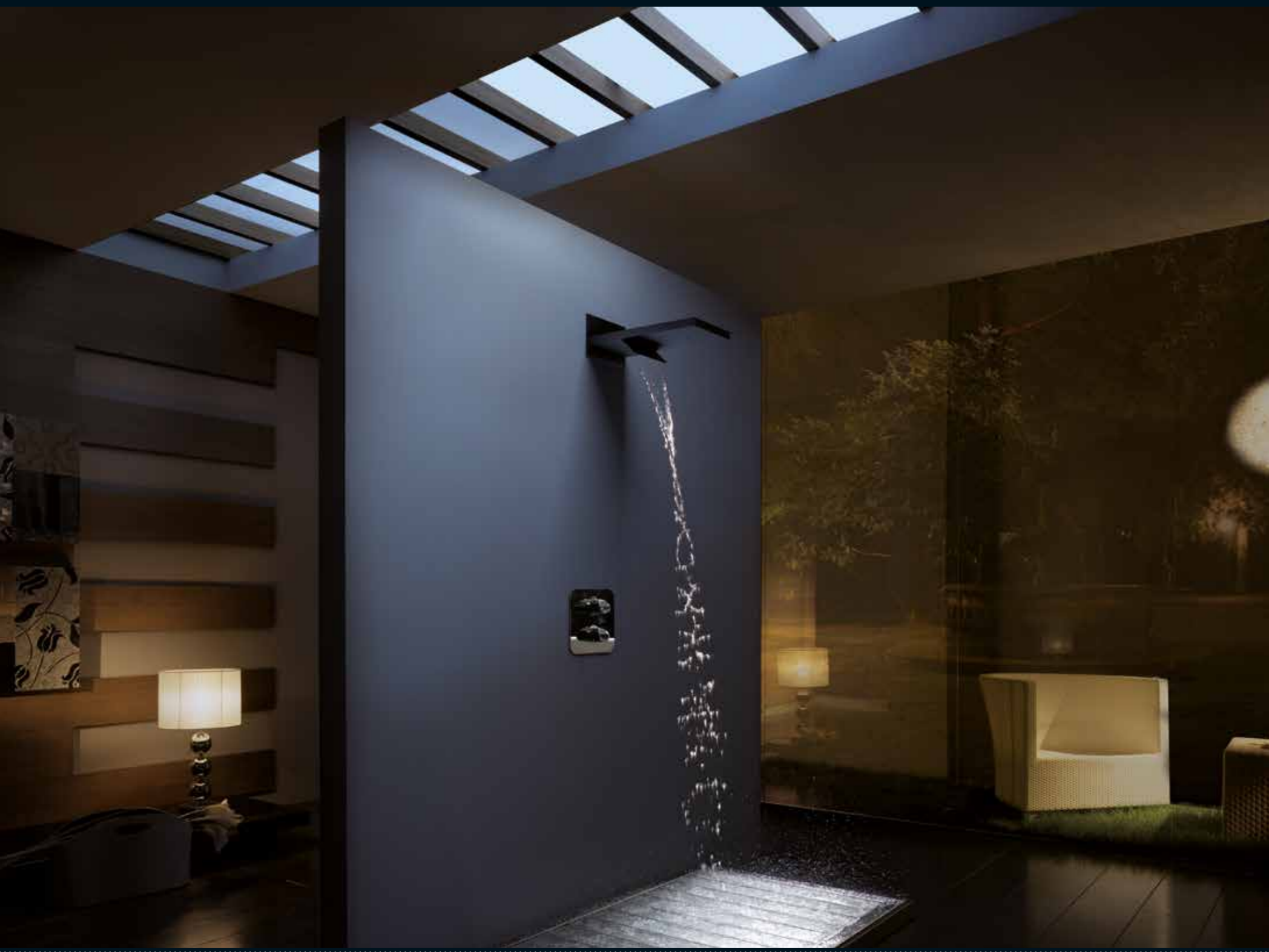

La linea GRAFFIO nasce dalla volontà di unire la consolidata esperienza di Nuova Osmo nella produzione di articoli per doccia al 100% Fabbricati in Italia, alla creatività, all'arte del "saper fare", all'unicità, tutta italiana, di lavorare materiali diversi traendo insegnamento da antiche tecniche di fabbricazione.

Questo forte sentimento di valorizzazione del lavoro e delle tradizioni artigiane ha trovato sviluppo in progetti innovativi con l'utilizzo di ceramica e vetro, rievocando il gesso, i tessuti damascati, la pelle, l'arte della luce e la forza dell'acqua nelle sue molteplici applicazioni. GRAFFIO: la forza e il coraggio dello Stile Fabbricato in Italia.

The GRAFFIO line was developed from the idea of combining the consolidated experience of the Nuova Osmo in the production of articles for showers "Made in Italy", with creativity and "know how" and the Italian uniqueness of working with diverse materials employing antique techniques. This strong sentiment and value of traditional craftsmanship has been developed within this innovative project utilising ceramic, glass, chalk, damask textiles, leather, the art of light and the strength of water in their multiple applications. GRAFFIO is the strength and courage of the Style Made in Italy.

La ligne GRAFFIO naît de la volonté d'unir à l'expérience que la Nuova Osmo a consolidée dans la Production 100% Italienne d'articles destinés à l'espace douche, la créativité, l'art du «savoir-faire», l'unicité typiquement italienne de travailler des matériaux divers et de s'enrichir d'anciennes techniques de fabrication. Le désir puissant de valoriser le travail et les traditions artisanales se retrouve dans le développement des projets innovants qui utilisent la céramique, le verre, et qui ré-invoquent le plâtre, les étoffes damassées, la peau, l'art de la lumière et la force de l'eau dans ses multiples applications. GRAFFIO: la force et le courage d'un Style Produit en Italie.

# E-COSCIENZA



GRAFFIO guarda al futuro: un costante impegno nella ricerca scientifica e tecnologica per prodotti ecosostenibili. L'azienda ha concentrato le sue capacità nello sviluppo di materiali alternativi, privi di sostanze tossiche, per trasformare le idee in articoli ben fatti, ecologici e riciclabili. L'attenzione a un bene prezioso come l'acqua e la sensibilità verso un utilizzo intelligente di questa risorsa hanno portato alla realizzazione di prodotti che racchiudono in sé estetica e rispetto per l'ambiente.

## ECOSCIENCE

GRAFFIO looks to the future: a constant commitment to researching technology and science to create environmentally sustainable products. The company has concentrated its ability on the development of alternative materials, not containing any toxic substances, to transform ideas into well made, ecological and recyclable articles. Attention paid to such a precious element as water, combined with the sensibility towards the intelligent use of this resource, brings us to the realisation of products that hold both style and respect for the environment.

## ECO CONSCIENCE

GRAFFIO regarde l'avenir: l'engagement constant dans la recherche scientifique et technologique pour produire dans le respect de l'environnement des articles écologiques. L'entreprise a concentré ses capacités sur le développement de matériaux alternatifs, non-toxiques, pour transformer ses idées en articles bien faits, écologiques et recyclables. L'attention réservée au bien précieux qu'est l'eau et la responsabilité de son intelligente utilisation a conduit l'entreprise vers la création de produits qui unissent l'esthétique et le respect de la nature.

# MADE IN ITALY



Vista del Lago d'Orta su cui si affaccia San Maurizio d'Opaglio, cuore del distretto industriale del rubinetto.  
Orta lake landscape. San Maurizio d'Opaglio, core of Italian faucets manufacturing district, is places along its bank.  
Vue du lac Orta, ou se trouve San Maurizio d'Opaglio, le cœur de l'industrie manufacturière de la robinetterie italienne.

## PRODOTTO IN ITALIA

Tutti gli articoli della linea GRAFFIO nascono e si sviluppano all'interno del processo produttivo Nuova Osmo a San Maurizio d'Opaglio in Piemonte. L'ufficio tecnico è attento allo sviluppo delle novità di mercato e sempre alla ricerca di innovazioni. La creatività e le capacità tecniche di Nuova Osmo consentono all'azienda di spaziare tra classico e moderno realizzando prodotti unici, senza tempo.

## MADE IN ITALY

All articles of the GRAFFIO line are made and developed within the production line Nuova Osmo at San Maurizio d'Opaglio, Piedmont. The technical department pays much attention to new developments on the market and is always searching for innovation. The creativity and technical ability of Nuova Osmo permits the company to range from classical to modern products thus remaining timeless.

## PRODUIT EN ITALIE

Tous les articles de la ligne GRAFFIO naissent et sont développés au sein du processus de production Nuova Osmo à San Maurizio d'Opaglio, Piémont. Attentif aux nouveautés du marché, le bureau technique est constamment à la recherche d'innovations. La créativité et les compétences techniques de Nuova Osmo permettent à l'entreprise de déployer, entre classique et moderne, sa création de produits intemporels.



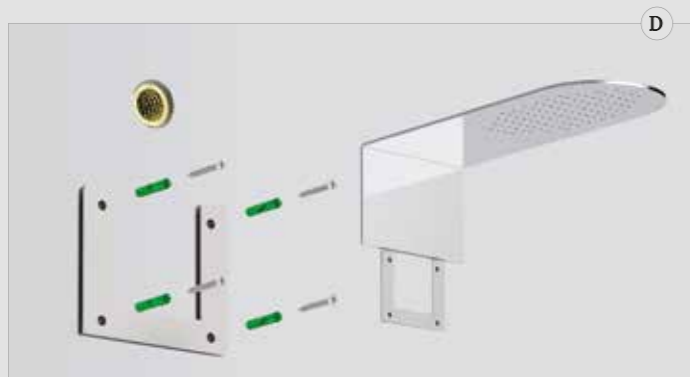
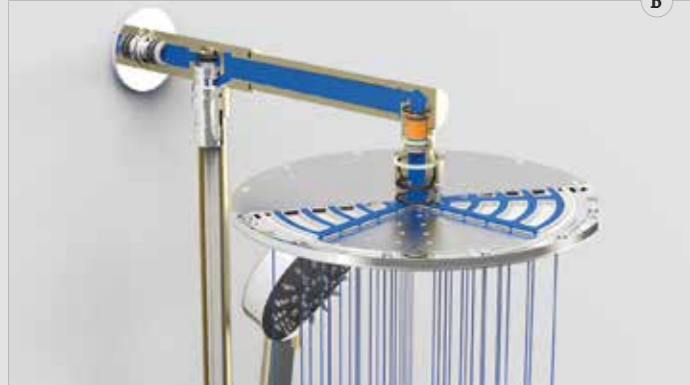
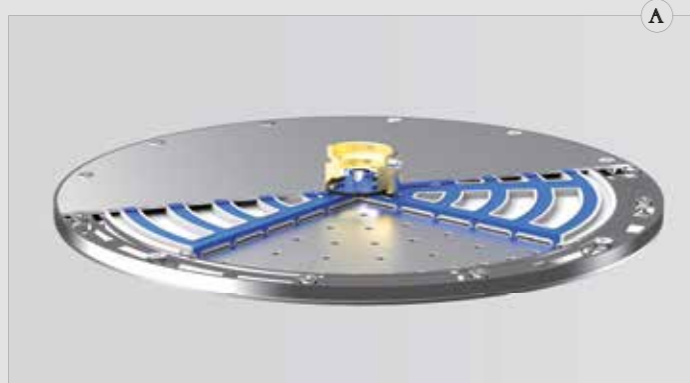

# TECNICA

GRAFFIO si distingue per i requisiti tecnici, le soluzioni innovative di installazione e l'utilizzo di materiali all'avanguardia.

I vantaggi di alcuni prodotti non sono sempre evidenti ma emergono con l'utilizzo.

- **EASY FIXING:** requisito semplice che rende facile e sicura l'installazione e la manutenzione.
- **MEMBRANE INTELLIGENTI e GETTI INNOVATIVI IN SILICONE (A)** per raggiungere minore spreco d'acqua ed energia e più comfort senza rilascio d'acqua alla chiusura dei rubinetti.
- Le cosiddette **LISTARELLE** dei soffioni **ONE WAY** termo-cromatiche permettono design innovativi e forniscono informazioni.
- Il **SILICONE** è il miglior materiale utilizzabile per i soffioni doccia. Materiale igienico, indistruttibile e di facile pulizia, può essere lavato anche in lavastoviglie. I soffioni **ISPEZIONABILI** della linea **GRAFFIO** garantiscono la possibilità di una semplice manutenzione che permette di avere nel tempo prodotti efficienti.
- **DIFFUSORI:** l'acqua all'interno dei soffioni viene distribuita in modo omogeneo grazie all'utilizzo di un apposito diffusore.
- **LIMITATORI DI PORTATA:** tutti i prodotti aziendali vengono studiati nell'ottica del miglior rapporto tra risparmio d'acqua ed energia e funzionalità.
- **DEVIATORE MINIMALISTA (B):** un progetto semplice ed innovativo che garantisce facilità di utilizzo e libertà progettuale.
- **BRACCI RINFORZATI (C):** garantiscono un'installazione più sicura anche per i soffioni di grandi dimensioni.
- **FISSAGGIO A SLITTA (D):** è ideale per le applicazioni più moderne, dove le pareti in cartongesso permettono agli architetti maggiore flessibilità. Fissare il prodotto alla parete senza pesare sulle tubature garantisce una perfetta applicazione anche in fase di ristrutturazione.

GRAFFIO distinguishes itself through its technical requisites; innovative solution for its installation and the utilisation of modern materials.

The advantages of many products are not always so evident, their quality emerges through their utilisation.

- **EASY FIXING:** a simple requisite which makes for an easy and secure installation and maintenance.
- **SMART MEMBRANES & INNOVATIVE SILICON JETS (A):** all research made by the technical department consent the perfection of the distribution of water in the showerhead. Achieving the least possible waste of water and energy, maximum comfort with no dripping once the tap has been turned off.
- The so called "**LISTARELLE ONE WAY**" of the shower head in the thermo-chromatic version permits innovative design and supply information.
- **SILICON** is the best material utilized for shower head. Hygienic, indestructible and easy to clean, it can even be cleaned in the dishwasher. Inspectionable shower heads from the **GRAFFIO** line are easily maintained, which permits one to keep efficient products over time.
- **DIFFUSERS:** the water inside the shower head is distributed evenly thanks to the use of a suitable diffuser.
- **FLOW LIMITERS:** All of our company products are studied with the objective to maximise the ratio between water and energy saving and functionality.
- **MINIMALISTIC DIVERTER (B):** a simple and innovative project, which guarantees ease of use and design freedom.
- **STRENGTHENED ARMS (C):** guarantee a more secure installation also for larger shower heads.
- **SLIDING FIXTURES (D):** through an innovative sliding fixture, the technical department of Nuova Osmo has developed a more modern application, whereby on walls made in plasterboard, the architects have more flexibility. The ability to fix the product onto the wall without weighing down the pipe-work, guarantees a perfect application in the restructuring phase.

GRAFFIO se distingue par sa technicité, par des solutions innovantes d'installation et par l'utilisation de matériaux à l'avant-garde.

Pas toujours évidents, les avantages de certains articles émergent en qualité à l'usage.

- **EASY:** le système qui simplifie et sécurise l'installation et en facilite l'entretien.
- **DES MEMBRANES INTELLIGENTES ET DES JETS INNOVANTS EN SILICONE (A):** les recherches menées par les bureaux techniques de l'entreprise ont abouti sur la distribution parfaite de l'eau à l'intérieur des pommes de douche. Ceci entraîne des économies d'eau et d'énergies et améliore le confort, sans qu'aucune perte d'eau n'advienne à la fermeture du robinet.
- Les **BAGUETTES** en silicone spécifiques aux pommes de douche **ONE WAY** versions thermochromatique permettent des esthétiques innovantes et fournissent des informations utiles.
- **DIFFUSEURS:** l'eau à l'intérieur des pommes de douche est distribuée de façon homogène grâce à l'utilisation de diffuseurs appropriés.
- Le silicone est, de fait, le meilleur matériel utilisable dans les pomme de douche car il est hygiénique, indestructible, facile à nettoyer et à entretenir.
- **LIMITEURS DE DEBIT:** tous les produits de l'entreprise sont étudiés dans l'optique du meilleur rapport entre l'économie de l'eau et de l'énergie et fonctionnalité.
- **INVERSEUR MINIMALISTE (B):** un projet simple et innovant qui garantit une facilité d'utilisation et une liberté de conception.
- **BRAS RENFORCES (C):** garantissant la bonne tenue des pommes de douche grands formats.
- **FIXATION COULISSANTE (D):** une innovation que le bureau technique de Nuova Osmo a réalisée pour que les architectes aient plus de flexibilité dans les applications modernes sur parois en carton plâtre. Fixer le produit à la paroi sans qu'il ne pèse sur la tuyauterie, garantit une installation parfaite même lors de rénovation.

Il tubo in ferro – il più tradizionale sistema di condotta d'acqua – è stato il vero ispiratore di TU-YO, linea completa di rubinetteria e articoli doccia applicabili sia in interno che in esterno.

*The most traditional system of water conduction, "iron tubes", was the true inspirer of the TU-YO project, a complete line of bathroom and shower articles having application both internally and externally.*

*"Le tuyau en fer", le plus traditionnel parmi les conduits d'eau, est la source inspiratrice du projet TU-YO, une collection complète de robinetterie pour la salle de bain et la douche, installables aussi bien à l'intérieur qu'à l'extérieur.*

# Tu-yo







Miscelatore lavabo TU-YO.  
✓ TU 003

TU-YO washbasin mixer.  
Mitigeur lavabo TU-YO.



VARIANTI / Variations / Variantes  
■ BI / NE / RU / AR / VE / IX



Miscelatore lavabo medio TU-YO.  
✓ TU 004

TU-YO medium high washbasin mixer.  
Mitigeur lavabo moyen TU-YO.



VARIANTI / Variations / Variantes  
■ BI / NE / RU / AR / VE / IX



Miscelatore lavabo alto TU-YO.  
✓ TU 005

TU-YO high washbasin mixer.  
Mitigeur lavabo col haut TU-YO.



VARIANTI / Variations / Variantes  
■ BI / NE / RU / AR / VE / IX

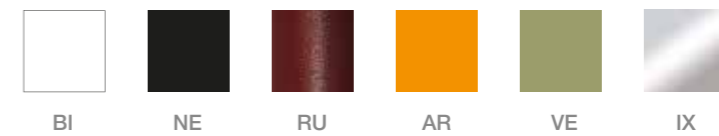

BI - Bianco/White/Blanc NE - Nero/Black/Noir RU - Ruggine/Rust/Rouille  
AR - Arancio/Orange VE - Verde/Green/Vert IX - Acciaio/Steel/Acier

CARTUCCIA IN CERAMICA/Ceramic cartridge/Cartouche céramique Ø 35 mm.  
SENZA SCARICO/Without waste/Sans vidage.

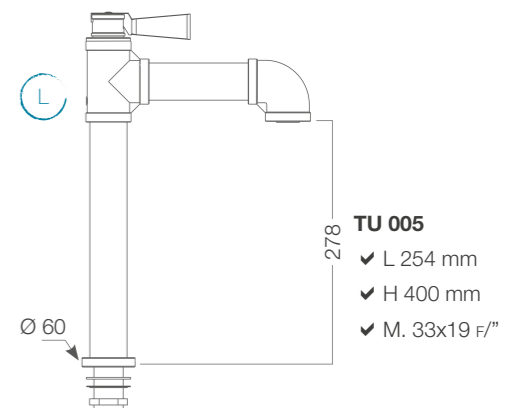
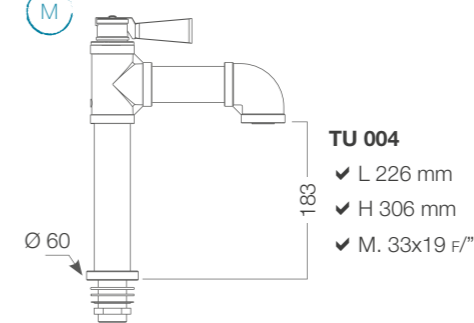
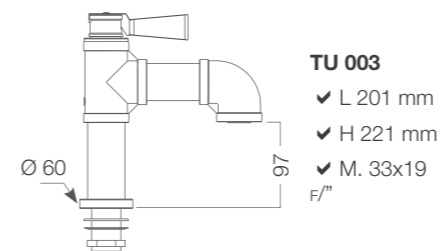



**Miscelatore lavabo incasso TU-YO con piastra tonda.**  
✓ TU 006

TU-YO built-in washbasin mixer with round plate.  
Mitigeur lavabo TU-YO encastré avec plaque ronde.



VARIANTI / Variations / Variantes  
■ BI / NE / RU / AR / VE / IX



**Miscelatore gruppo vasca incasso TU-YO con piastra tonda.**  
✓ TU 007

TU YO concealed bath mixer with round plate  
Mitigeur baignoire TU YO à encastrer avec plaque ronde.



VARIANTI / Variations / Variantes  
■ BI / NE / RU / AR / VE / IX

**Miscelatore TU-YO, piantana.**  
✓ TU 001

TU-YO floor mounted mixer.  
Mitigeur TU-YO, colonnette.



VARIANTI / Variations / Variantes  
■ BI / NE / RU / AR / VE / IX



**Miscelatore TU-YO, piantana con accessori\*.**  
✓ TU 002

TU-YO mixer, floor mounted with accessories\*.  
Mitigeur TU-YO, colonnette équipée\*.



VARIANTI / Variations / Variantes  
■ BI / NE / RU / AR / VE / IX



\*Portasciugamano e portasapone in ceramica tinta unita/  
Towel holder and plain colour ceramic soap dish/  
Porte-serviette et porte-savon en céramique couleur unie.  
Con portasapone decorato/With decorated soap dish/Avec porte-savon décoré (ASR ASV DM LE)



**Miscelatore bidet TU-YO.**  
✓ TU 010

TU-YO bidet mixer.  
Mitigeur bidet TU-YO.



VARIANTI / Variations / Variantes  
■ BI / NE / RU / AR / VE / IX



**Miscelatore incasso TU-YO, con deviatore 2 vie.**  
✓ TU 020

TU-YO built-in bath mixer with 2 ways diverter.  
Mitigeur baignoire encastré TU-YO avec inverseur 2 voies.



VARIANTI / Variations / Variantes  
■ BI / NE / RU / AR / VE / IX



**Miscelatore incasso TU-YO.**  
✓ TU 030

TU-YO built-in bath mixer.  
Mitigeur baignoire encastré TU-YO.



VARIANTI / Variations / Variantes  
■ BI / NE / RU / AR / VE / IX



BI - Bianco/White/Blanc NE - Nero/Black/Noir RU - Ruggine/Rust/Rouille  
AR - Arancio/Orange VE - Verde/Green/Vert IX - Acciaio/Steel/Acier

CARTUCCIA IN CERAMICA/Ceramic cartridge/Cartouche céramique Ø 35 mm.  
SENZA SCARICO/Without waste/Sans vidage.

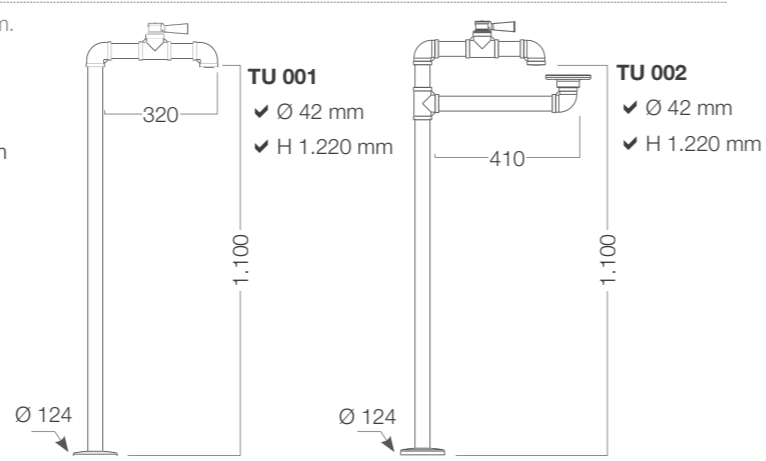
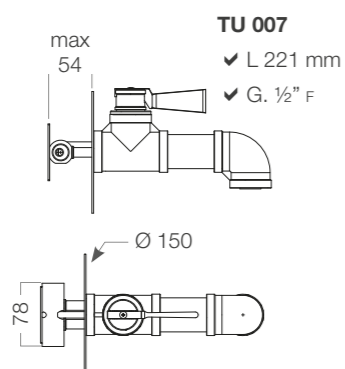
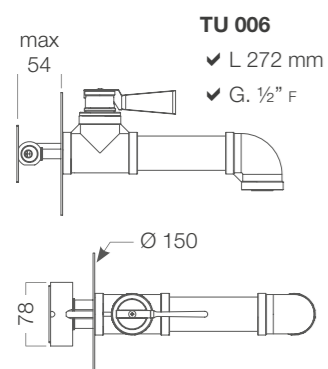

CARTUCCIA IN CERAMICA/Ceramic cartridge/Cartouche céramique Ø 35 mm.  
SENZA SCARICO/Without waste/Sans vidage.

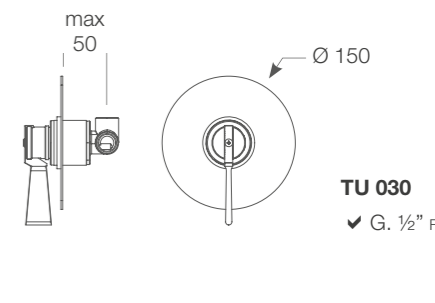
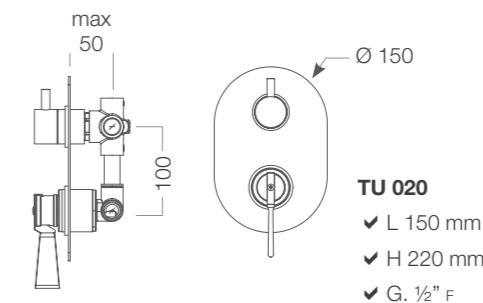
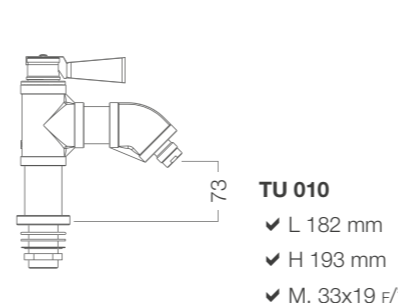



Miscelatore cucina TU-YO, leva laterale, girevole.

✓ TU 040

TU-YO kitchen faucet, integrated lateral handle, swivel neck.

Mitigeur cuisine TU-YO, levier latéral, tournant.



VARIANTI / Variations / Variantes

■ BI / NE / RU / AR / VE / IX



Miscelatore cucina TU-YO, canna alta, girevole.

✓ TU 041

TU-YO high kitchen faucet, swivel neck.

Mitigeur cuisine TU-YO, bec haut, tournant.



VARIANTI / Variations / Variantes

■ BI / NE / RU / AR / VE / IX

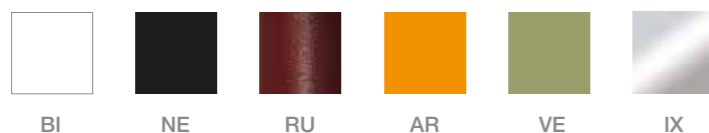

BI - Bianco/White/Blanc NE - Nero/Black/Noir RU - Ruggine/Rust/Rouille  
AR - Arancio/Orange VE - Verde/Green/Vert IX - Acciaio/Steel/Acier

CARTUCCIA IN CERAMICA/  
Ceramic cartridge/  
Cartouche céramique Ø 35 mm.

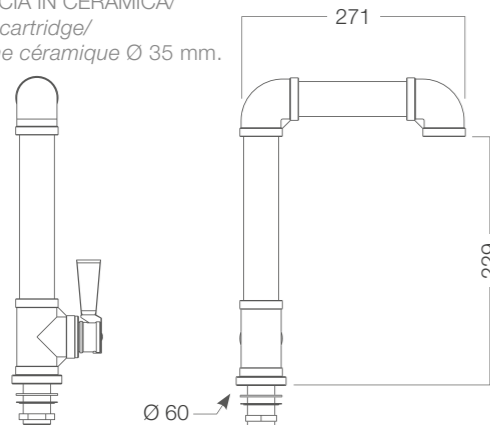

**TU 040**  
✓ H 370 mm  
✓ M. 33x19 F/"

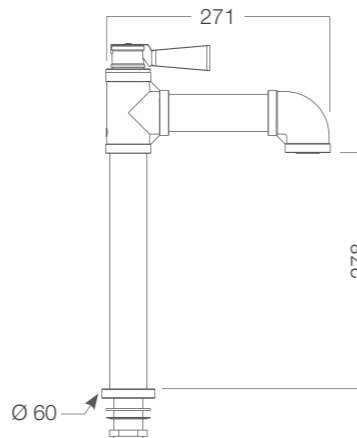

**TU 041**  
✓ H 400 mm  
✓ M. 33x19 F/"



Braccio doccia TU-YO con deviatore a catenella, soffione CIRANÒ Ø 250 mm, doccia MINIMALISTA in ABS\*, supporto doccia fisso TU-YO, flessibile RAGNO (per bianco e nero) o SILVER 1750 mm.

(Soffione tinta unita □ BI ■ RO ■ NE)\*\*

✓ TU 801

TU-YO shower arm with diverter chain, CIRANÒ showerhead Ø 250 mm, MINIMALISTA ABS hand shower\*, TU-YO fixed shower holder, RAGNO (on white and black) or SILVER flexible hose 1750 mm. (Plain colour showerhead)\*\*.

Bras douche TU-YO avec inverseur à chaîne, pomme de douche CIRANÒ Ø 250 mm, douchette MINIMALISTA en ABS\*, support fixe TU-YO, flexible RAGNO (pour blanc et noir) ou SILVER 1750 mm. (Pomme de douche couleur unie)\*\*.



VARIANTI / Variations / Variantes

■ BI / NE / RU / AR / VE / IX

\* BI / NE - Bianca o nera/White or black/Blanche ou noire.  
RU / AR / VE / IX - Cromata/Chrome plated/Chrome.

\*\* Con soffione decorato/With decorated showerhead/Avec pomme de douche décorée

(■ ASR ■ ASV ■ DM ■ LE)

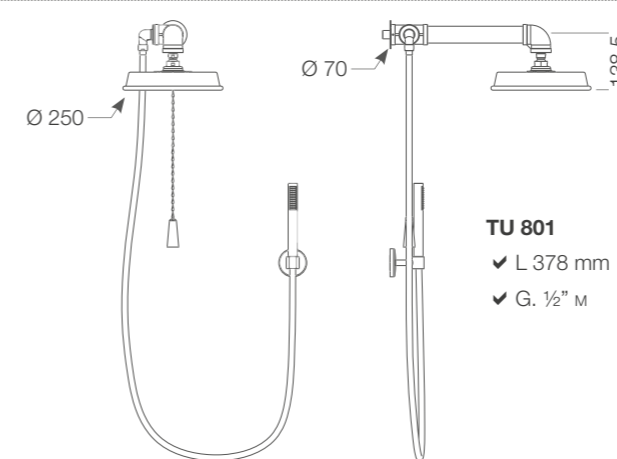

**TU 801**  
✓ L 378 mm  
✓ G. 1/2" M

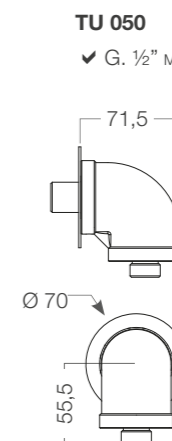

**TU 050**  
✓ G. 1/2" M



Presca acqua TU-YO con rosone Ø70 mm

✓ TU 050

TU YO water outlet with rosette Ø70 mm

Prise d'eau TU YO avec rosace Ø70 mm



VARIANTI / Variations / Variantes

■ BI / NE / RU / AR / VE / IX



Supporto fisso TU-YO. (Colore coordinato).

✓ TU 906

TU-YO fixed shower holder. (Coordinated colour).

Support fixe TU-YO. (Couleur coordonnée).

VARIANTI / Variations / Variantes

■ BI / NE / RU / AR / VE / IX

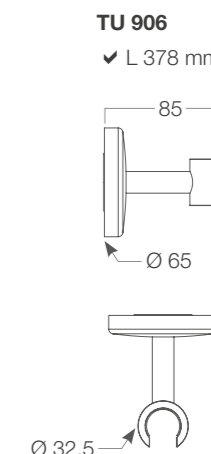

**TU 906**  
✓ L 378 mm



Braccio doccia TU-YO,  
soffione CIRANÒ Ø 250 mm.  
(Soffione tinta unita

□ BI ■ RO ■ NE)\*

✓ TU 800

TU-YO shower arm, CIRANÒ  
showerhead Ø 250 mm.  
(Plain colour showerhead)\*.

Bras douche TU-YO, pomme  
de douche CIRANÒ Ø 250 mm.  
(Pomme de douche couleur unie)\*.



VARIANTI / Variations / Variantes

■ BI / NE / RU / AR / VE / IX

\* Con soffione decorato/  
With decorated showerhead/  
Avec pomme de douche décorée  
(ASR ASV DM LE)



Braccio doccia TU-YO.

✓ TU 090

TU-YO shower arm.

Bras douche TU-YO.



VARIANTI / Variations / Variantes

■ BI / NE / RU / AR / VE / IX



Braccio doccia TU-YO  
con deviatore a catenella.

✓ TU 091

TU-YO shower arm with diverter pull.

Bras douche TU-YO avec inverseur  
à chaîne.



VARIANTI / Variations / Variantes

■ BI / NE / RU / AR / VE / IX

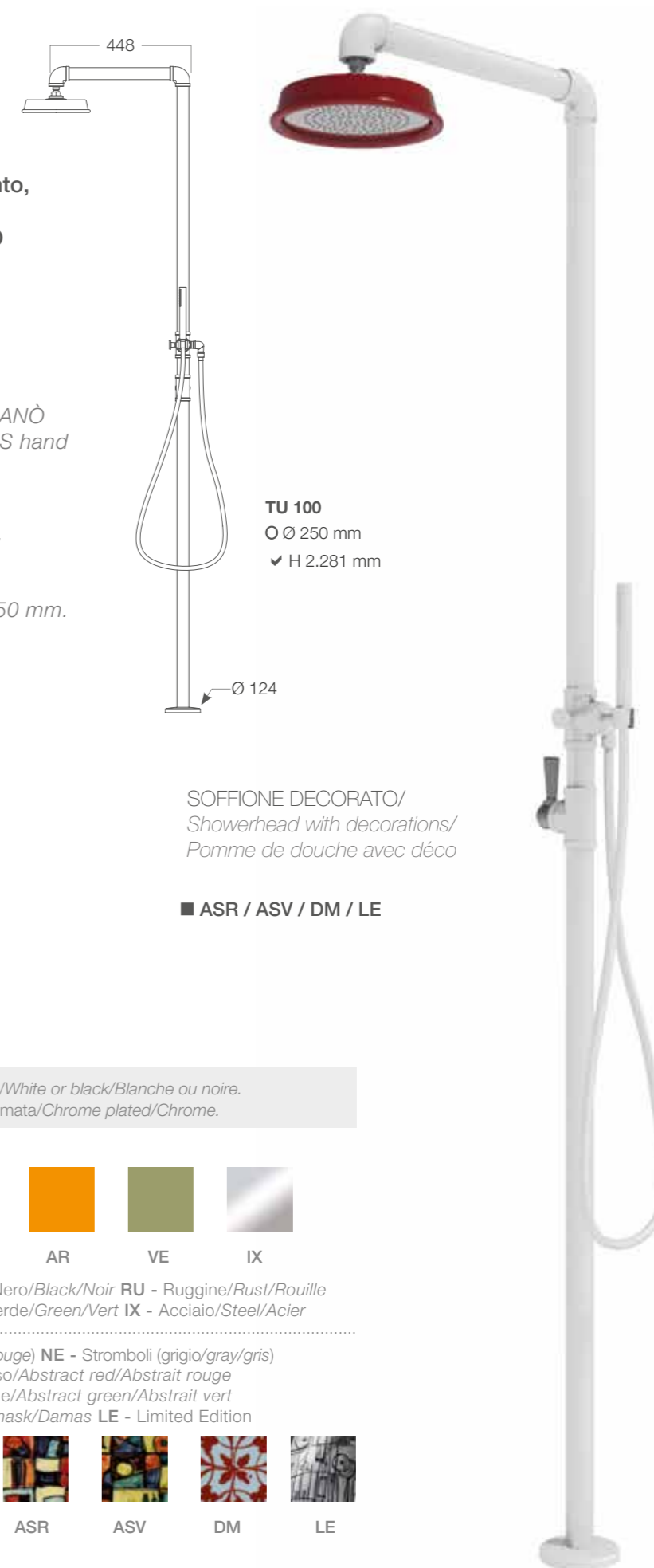

Colonna doccia TU-YO attacco pavimento,  
soffione CIRANÒ Ø 250 mm, doccia  
MINIMALISTA in ABS\*, flessibile RAGNO  
(per bianco e nero) o SILVER 1750 mm.  
(Soffione tinta unita □ BI ■ RO ■ NE)

✓ TU 100

TU-YO floor mounted shower column, CIRANÒ  
showerhead Ø 250 mm, MINIMALISTA ABS hand  
shower\*, RAGNO (on white and black)  
or SILVER flexible hose 1750 mm.

Colonne de douche TU-YO raccord au sol,  
pomme de douche CIRANÒ Ø 250 mm,  
douchette MINIMALISTA en ABS\*, flexible  
RAGNO (pour blanc et noir) ou SILVER 1750 mm.



VARIANTI-COLONNA/

Variations-column/  
Variantes-colonne

■ BI / NE / RU / AR / VE / IX

TU 100  
O Ø 250 mm  
✓ H 2.281 mm

SOFFIONE DECORATO/  
Showerhead with decorations/  
Pomme de douche avec déco

■ ASR / ASV / DM / LE

\* BI / NE - Bianca o nera/White or black/Blanche ou noire.  
RU / AR / VE / IX - Cromata/Chrome plated/Chrome.



BI NE RU AR VE IX

BI - Bianco/White/Blanc NE - Nero/Black/Noir RU - Ruggine/Rust/Rouille  
AR - Arancio/Orange VE - Verde/Green/Vert IX - Acciaio/Steel/Acier

RO - Jessica (rosso/red/rouge) NE - Stromboli (grigio/gray/gris)  
ASR - Astratto rosso/Abstract red/Abstrait rouge  
ASV - Astratto verde/Abstract green/Abstrait vert  
DM - Damascato/Damask/Damas LE - Limited Edition



BI RO NE ASR ASV DM LE

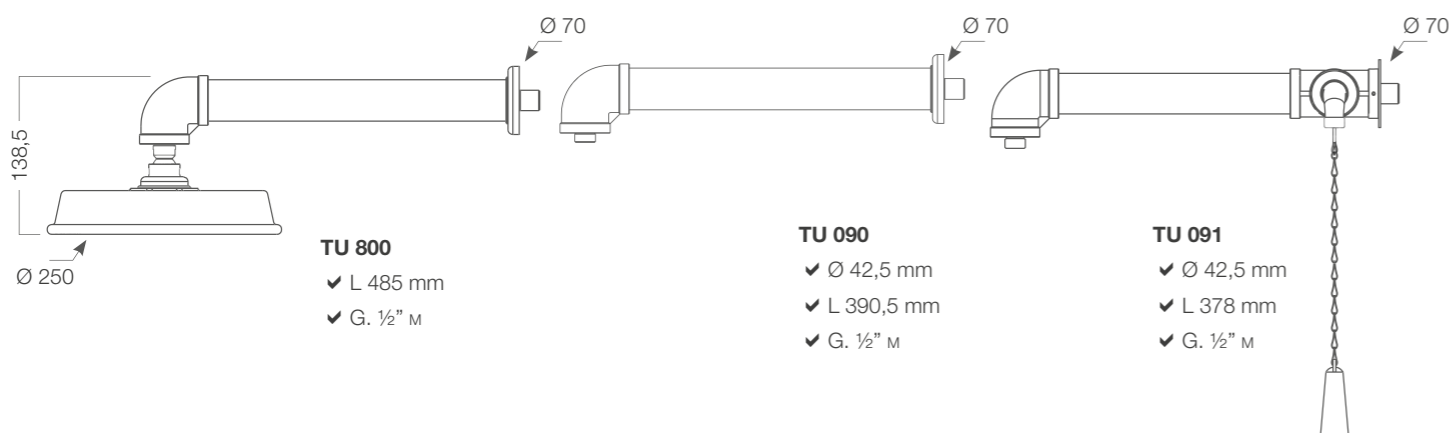

TU 800

✓ L 485 mm  
✓ G. ½" M

TU 090

✓ Ø 42,5 mm  
✓ L 390,5 mm  
✓ G. ½" M

TU 091

✓ Ø 42,5 mm  
✓ L 378 mm  
✓ G. ½" M

Colonna doccia TU-YO attacco pavimento con deviatore.

✓ TU 190

*TU-YO floor mounted shower column with diverter.*

*Colonne de douche TU-YO raccord au sol avec inverseur.*



VARIANTI / Variations / Variantes

■ BI / NE / RU / AR / VE / IX

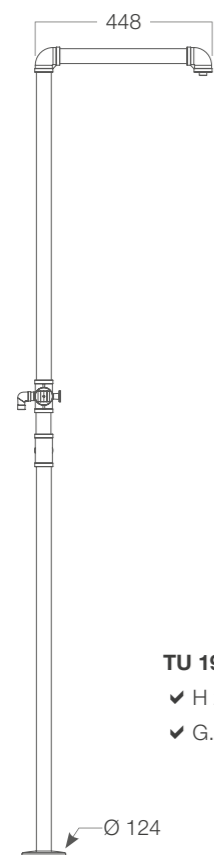

**TU 190**

✓ H 2.281 mm

✓ G. ½" M



BI - Bianco/White/Blanc NE - Nero/Black/Noir RU - Ruggine/Rust/Rouille  
AR - Arancio/Orange VE - Verde/Green/Vert IX - Acciaio/Steel/Acier

Colonna doccia TU-YO attacco pavimento per esterno.

✓ TU 180-00

*TU-YO outdoors floor mounted shower column.*

*Colonne de douche TU-YO raccord au sol pour extérieur.*



VARIANTI / Variations / Variantes

■ BI / NE / RU / AR / VE / IX



Colonna doccia TU-YO attacco pavimento per esterno, soffione tondo SCATTO in ABS.

✓ TU 180

*TU-YO outdoors floor mounted shower column, SCATTO round ABS showerhead.*

*Colonne de douche TU-YO raccord au sol pour extérieur, pomme de douche ronde SCATTO en ABS.*



VARIANTI / Variations / Variantes

■ BI / NE / RU / AR / VE / IX

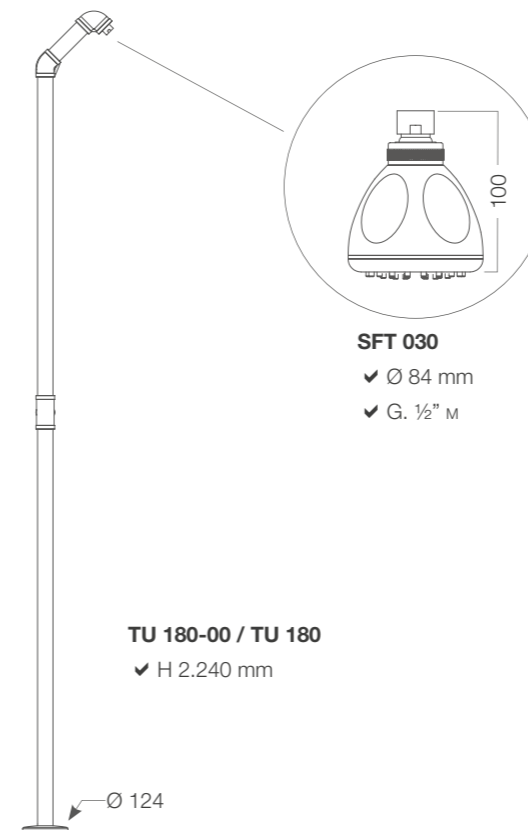

**SFT 030**

✓ Ø 84 mm

✓ G. ½" M

**TU 180-00 / TU 180**

✓ H 2.240 mm

Colonna doccia incasso TU-YO, soffione CIRANÒ Ø 250 mm, doccia MINIMALISTA in ABS\*, flessibile RAGNO (per bianco e nero) o SILVER 1750 mm.  
(Soffione tinta unita  BI  RO  NE)

✓ TU 120

TU-YO built-in shower column, CIRANÒ showerhead Ø 250 mm, MINIMALISTA ABS hand shower\*, RAGNO (on white and black) or SILVER flexible hose 1750 mm.

Colonne de douche encastrée TU-YO, pomme de douche CIRANÒ Ø 250 mm, douchette MINIMALISTA en ABS\*, flexible RAGNO (pour blanc et noir) ou SILVER 1750 mm.



\* BI / NE - Bianca o nera/White or black/Blanche ou noire.  
RU / AR / VE / IX - Cromata/Chrome plated/Chrome.



SOFFIONE DECORATO/  
Showerhead with decorations/  
Pomme de douche avec déco

ASR / ASV / DM / LE

VARIANTI-COLONNA/  
Variations-column/  
Variantes-colonne

■ BI / NE / RU / AR / VE / IX

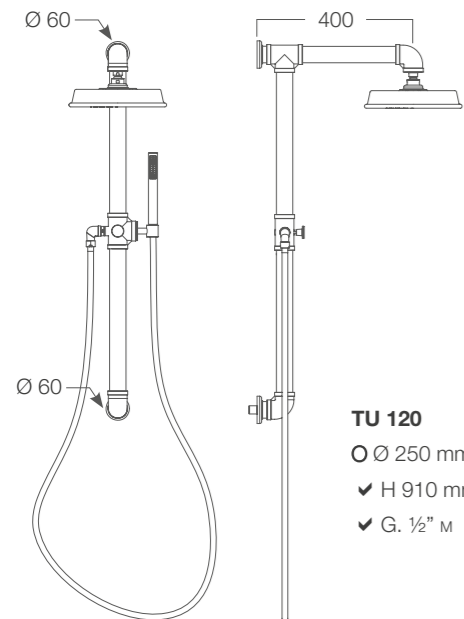

**TU 120**  
O Ø 250 mm  
✓ H 910 mm  
✓ G. 1/2" M



BI - Bianco/White/Blanc NE - Nero/Black/Noir RU - Ruggine/Rust/Rouille  
AR - Arancio/Orange VE - Verde/Green/Vert IX - Acciaio/Steel/Acier

RO - Jessica (rosso/red/rouge) NE - Stromboli (grigio/gray/gris)  
ASR - Astratto rosso/Abstract red/Abstrait rouge  
ASV - Astratto verde/Abstract green/Abstrait vert  
DM - Damascato/Damask/Damas LE - Limited Edition



BI RO NE ASR ASV DM LE



Lo spirito di ricerca di Graffio incontra la creatività delle ceramiche siciliane dell'artigiano Giovanni D'Angelo: così nascono le forme e i colori di CIRANÒ, una collezione di pezzi unici lavorati secondo le tecniche tradizionali.

*Graffio's spirit of research meets the creativity of the Sicilian ceramic made by craftsman Giovanni D'Angelo: that's the birth of the shapes and colours of CIRANÒ, a collection of unique pieces, hand crafted according to traditional techniques.*

*L'esprit de recherche de Graffio rencontre la créativité des Céramiques Siciliennes du maître artisan Giovanni D'Angelo: ainsi naissent les formes et les couleurs de CIRANÒ, une collection des pièces uniques travaillées et décorées selon techniques traditionnelles.*

# Ciranò





Soffione tondo CIRANÒ Ø 160 mm,  
braccio doccia tondo 350 mm.

✓ CI 801

CIRANÒ round showerhead Ø 160 mm,  
round shower arm 350 mm.

Pomme de douche ronde CIRANÒ  
Ø 160 mm, bras mural rond 350 mm.



VARIANTI / Variations / Variantes

■ BI / RO / NE / ASR / ASV / DM / LE

Soffione tondo CIRANÒ Ø 200 mm,  
braccio doccia tondo 350 mm.

✓ CI 802

CIRANÒ round showerhead Ø 200 mm,  
round shower arm 350 mm.

Pomme de douche ronde CIRANÒ  
Ø 200 mm, bras mural rond 350 mm.



VARIANTI / Variations / Variantes

■ BI / RO / NE / ASR / ASV / DM / LE

Soffione tondo CIRANÒ Ø 250 mm,  
braccio doccia tondo 400 mm.

✓ CI 803

CIRANÒ round showerhead Ø 250 mm,  
round shower arm 400 mm.

Pomme de douche ronde CIRANÒ  
Ø 250 mm, bras mural rond 400 mm.



VARIANTI / Variations / Variantes

■ BI / RO / NE / ASR / ASV / DM / LE



BI - Bianco/White/Blanc RO - Jessica (rosso/red/rouge) NE - Stromboli (grigio/gray/gris) ASR - Astratto rosso/Abstract red/Abstrait rouge

ASV - Astratto verde/Abstract green/Abstrait vert DM - Damascato/Damask/Damas LE - Limited Edition

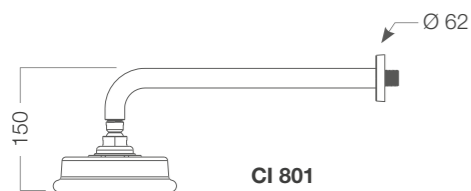

CI 801

Ø Ø 160 mm  
✓ L 438,5 mm  
✓ G. ½" M

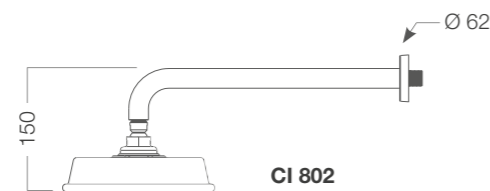

CI 802

Ø Ø 200 mm  
✓ L 458 mm  
✓ G. ½" M

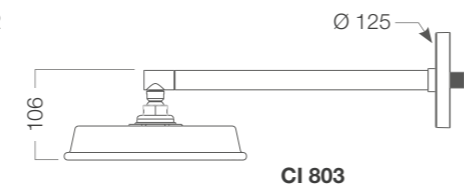

CI 803

Ø Ø 250 mm  
✓ L 510 mm  
✓ G. ½" M

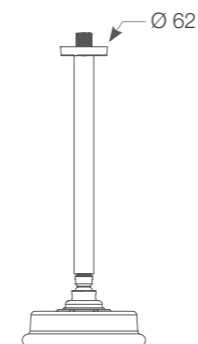

CI 804

Ø Ø 160 mm  
✓ H 395 mm  
✓ G. ½" M

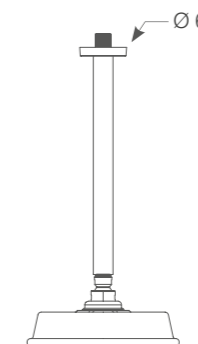

CI 805

Ø Ø 200 mm  
✓ H 395 mm  
✓ G. ½" M

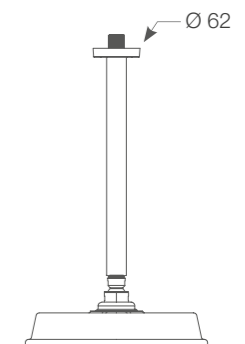

CI 806

Ø Ø 250 mm  
✓ H 395 mm  
✓ G. ½" M

Soffione tondo CIRANÒ Ø 160 mm,  
braccio doccia tondo a soffitto 300 mm.

✓ CI 804

CIRANÒ round showerhead Ø 160 mm,  
round ceiling mounted shower arm 300 mm.

Pomme de douche ronde CIRANÒ Ø 160 mm,  
bras plafond rond 300 mm.



VARIANTI / Variations / Variantes

■ BI / RO / NE / ASR / ASV / DM / LE

Soffione tondo CIRANÒ Ø 200 mm,  
braccio doccia tondo a soffitto 300 mm.

✓ CI 805

CIRANÒ round showerhead Ø 200 mm,  
round ceiling mounted shower arm 300 mm.

Pomme de douche ronde CIRANÒ Ø 200 mm,  
bras plafond rond 300 mm.



VARIANTI / Variations / Variantes

■ BI / RO / NE / ASR / ASV / DM / LE

Soffione tondo CIRANÒ Ø 250 mm,  
braccio doccia tondo a soffitto 300 mm.

✓ CI 806

CIRANÒ round showerhead Ø 250 mm,  
round ceiling mounted shower arm 300 mm.

Pomme de douche ronde CIRANÒ Ø 250 mm,  
bras plafond rond 300 mm.



VARIANTI / Variations / Variantes

■ BI / RO / NE / ASR / ASV / DM / LE





**Soffione tondo CIRANÒ Ø 160 mm.**

✓ CI 001

*CIRANÒ round showerhead Ø 160 mm.*

*Pomme de douche ronde CIRANÒ Ø 160 mm.*



VARIANTI / Variations / Variantes

■ BI / RO / NE / ASR / ASV / DM / LE

**Soffione tondo CIRANÒ Ø 250 mm.**

✓ CI 003

*CIRANÒ round showerhead Ø 250 mm.*

*Pomme de douche ronde CIRANÒ Ø 250 mm.*



VARIANTI / Variations / Variantes

■ BI / RO / NE / ASR / ASV / DM / LE

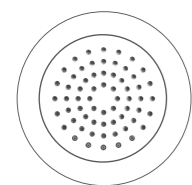

**CI 001**  
 ✓ Ø 160 mm  
 ✓ H 46 mm  
 ✓ G. ½" F

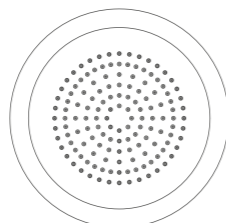

**CI 002**  
 ✓ Ø 200 mm  
 ✓ H 46 mm  
 ✓ G. ½" F

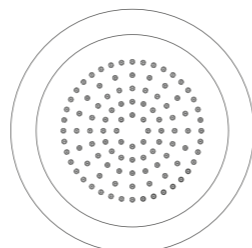

**CI 003**  
 ✓ Ø 250 mm  
 ✓ H 46 mm  
 ✓ G. ½" F

**Soffione tondo CIRANÒ Ø 200 mm.**

✓ CI 002

*CIRANÒ round showerhead Ø 200 mm.*

*Pomme de douche ronde CIRANÒ Ø 200 mm.*



VARIANTI / Variations / Variantes

■ BI / RO / NE / ASR / ASV / DM / LE



**Seduta in ceramica CIRANÒ.**

✓ CI 900

*CIRANÒ ceramic stool, dimensions.*

*Assise en céramique CIRANÒ, dimensions.*



VARIANTI / Variations / Variantes

■ BI / RO / NE / ASR / ASV / DM / LE



**CI 900**  
 ✓ Ø MAX 400 mm  
 ✓ H MAX 420 mm

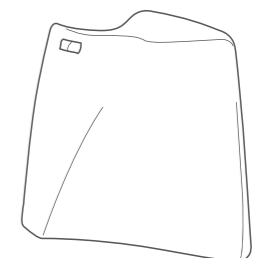

BI - Bianco/White/Blanc RO - Jessica (rosso/red/rouge) NE - Stromboli (grigio/gray/gris)  
 ASR - Astratto rosso/Abstract red/Abstrait rouge ASV - Astratto verde/Abstract green/Abstrait vert  
 DM - Damascato/Damask/Damas LE - Limited Edition

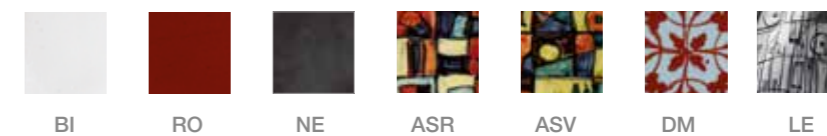

Grazie al sodalizio con il mastro vetraio Nicodemo Marcon, nella linea LAGUNA le esigenze tecniche della doccia incontrano l'arte del vetro di Murano, con risultati d'eccellenza in termini di colore, eleganza e pregio.

*Thanks to the association with "maestro" glazier Nicodemo Marcon, in the LAGUNA Collection the technical requirements of the shower meet the venetian art of Murano glass, with excellent results in terms of colours, elegance and prestige.*

*Grâce à l'alliance établie avec le renommé Maître verrier Nicodemo Marcon, dans la collection LAGUNA les exigences techniques de la pomme de douche rencontrent l'art du verre de Murano, aboutissant à l'excellence d'une esthétique aux transparences colorées, précieuse et raffinée.*

# Laguna

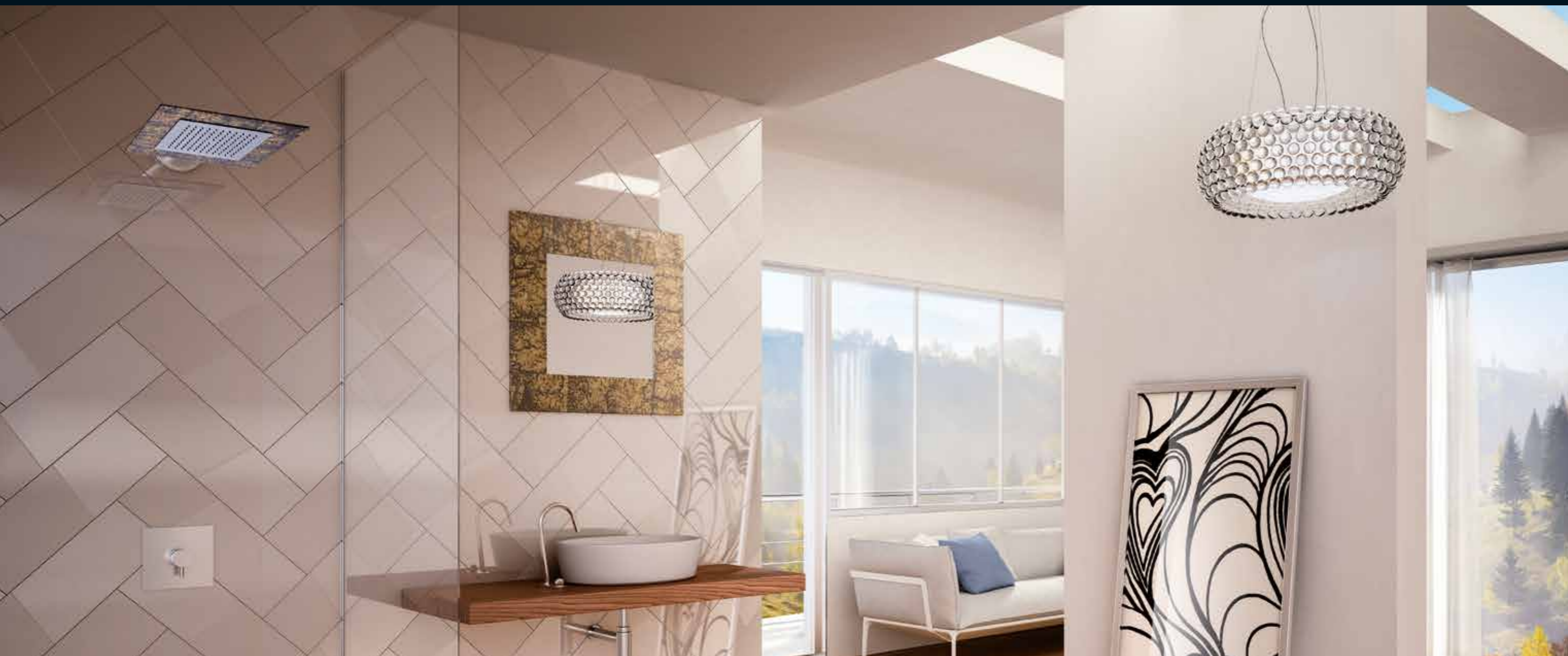



Soffione tondo LAGUNA Ø 400 mm.

✓ LA 001

LAGUNA round showerhead Ø 400 mm.

Pomme de douche ronde LAGUNA Ø 400 mm.



VARIANTI / Variations / Variantes

- PME502 / PM110 / MA77 / MA02 / AG
- EOD191 / EO40 / ORO / NO40
- NO40 NEO / EOD191 NEO

SOFFIONE CROMO /  
Chrome showerhead / Pomme de douche chrome

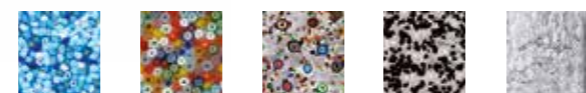

PME502 PM110 MA77 MA02 AG

SOFFIONE ORO /  
Gold showerhead / Pomme de douche or

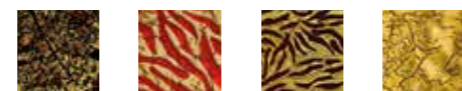

EOD191 EO40 NO40 ORO

SOFFIONE NERO OPACO /  
Matte black showerhead / Pomme de douche noire mate



EOD191 NO40

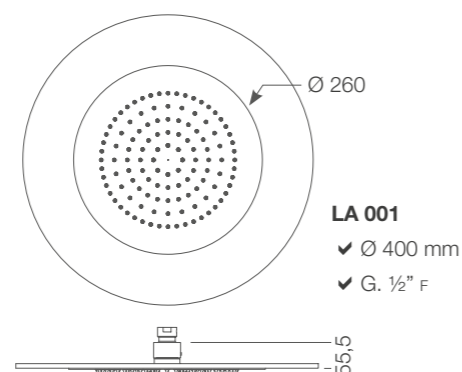

**LA 001**  
✓ Ø 400 mm  
✓ G. ½" F



Soffione tondo LAGUNA Ø 400 mm,  
braccio doccia tondo 400 mm.

✓ LA 801

LAGUNA round showerhead Ø 400 mm,  
round shower arm 400 mm.

Pomme de douche ronde LAGUNA  
Ø 400 mm, bras mural rond 400 mm.



VARIANTI / Variations / Variantes

- PME502 / PM110 / MA77 / MA02 / AG
- EOD191 / EO40 / ORO / NO40
- NO40 NEO / EOD191 NEO

PME502 - Murrina azzurra/Light blue murrina/Murrina bleu clair PM110 - Murrina pastello/Pastel colour murrina/Murrina pastel  
MA77 - Murrina pastello-base argento/Pastel colour murrina-silver leaf/Murrina pastel-base argent  
MA02 - Murrina nera-base argento/Black murrina-silver leaf/Murrina noir-base argent EOD191 - Fantasia scura-base oro/Dark pattern-golden leaf/  
Fantaisie foncée-base or EO40 - Alga rossa-base oro/Red seaweed-golden leaf/Algue rouge-base or  
NO40 - Alga nera/Black Seaweed/Algue noire ORO - Oro/Gold/Or AG - Argento/Silver/Argent



Soffione tondo LAGUNA Ø 400 mm,  
braccio doccia tondo attacco a soffitto  
300 mm.

✓ LA 803

LAGUNA round showerhead Ø 400 mm,  
round ceiling mounted shower arm 300 mm.

Pomme de douche ronde LAGUNA  
Ø 400 mm, bras plafond rond 300 mm.



VARIANTI / Variations / Variantes

- PME502 / PM110 / MA77 / MA02 / AG
- EOD191 / EO40 / ORO / NO40
- NO40 NEO / EOD191 NEO



**LA 801**  
O Ø 400 mm  
✓ L 590 mm  
✓ G. ½" M

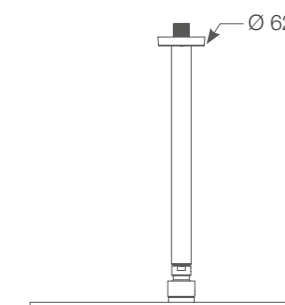

**LA 803**  
O Ø 400 mm  
✓ H 357 mm  
✓ G. ½" M

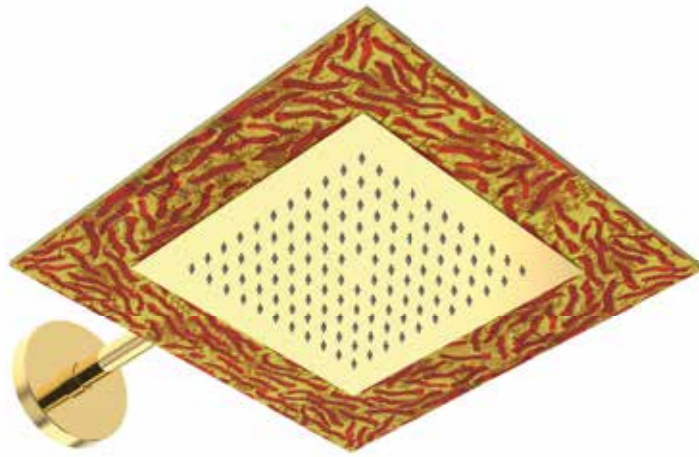

Soffione quadro LAGUNA 400x400 mm,  
braccio doccia tondo 400 mm.

✓ LA 802

LAGUNA square showerhead 400x400 mm,  
round shower arm 400 mm.

Pomme de douche carrée LAGUNA  
400x400 mm, bras mural rond 400 mm.



VARIANTI / Variations / Variantes

- PME502 / PM110 / MA77 / MA02 / AG
- EOD191 / EO40 / ORO / NO40
- NO40 NEO / EOD191 NEO



Soffione quadro LAGUNA 400x400 mm,  
braccio doccia tondo attacco a soffitto 300 mm.

✓ LA 804

LAGUNA square showerhead 400x400 mm,  
round ceiling mounted shower arm 300 mm.

Pomme de douche carrée LAGUNA 400x400 mm,  
bras plafond rond 300 mm.



VARIANTI / Variations / Variantes

- PME502 / PM110 / MA77 / MA02 / AG
- EOD191 / EO40 / ORO / NO40
- NO40 NEO / EOD191 NEO

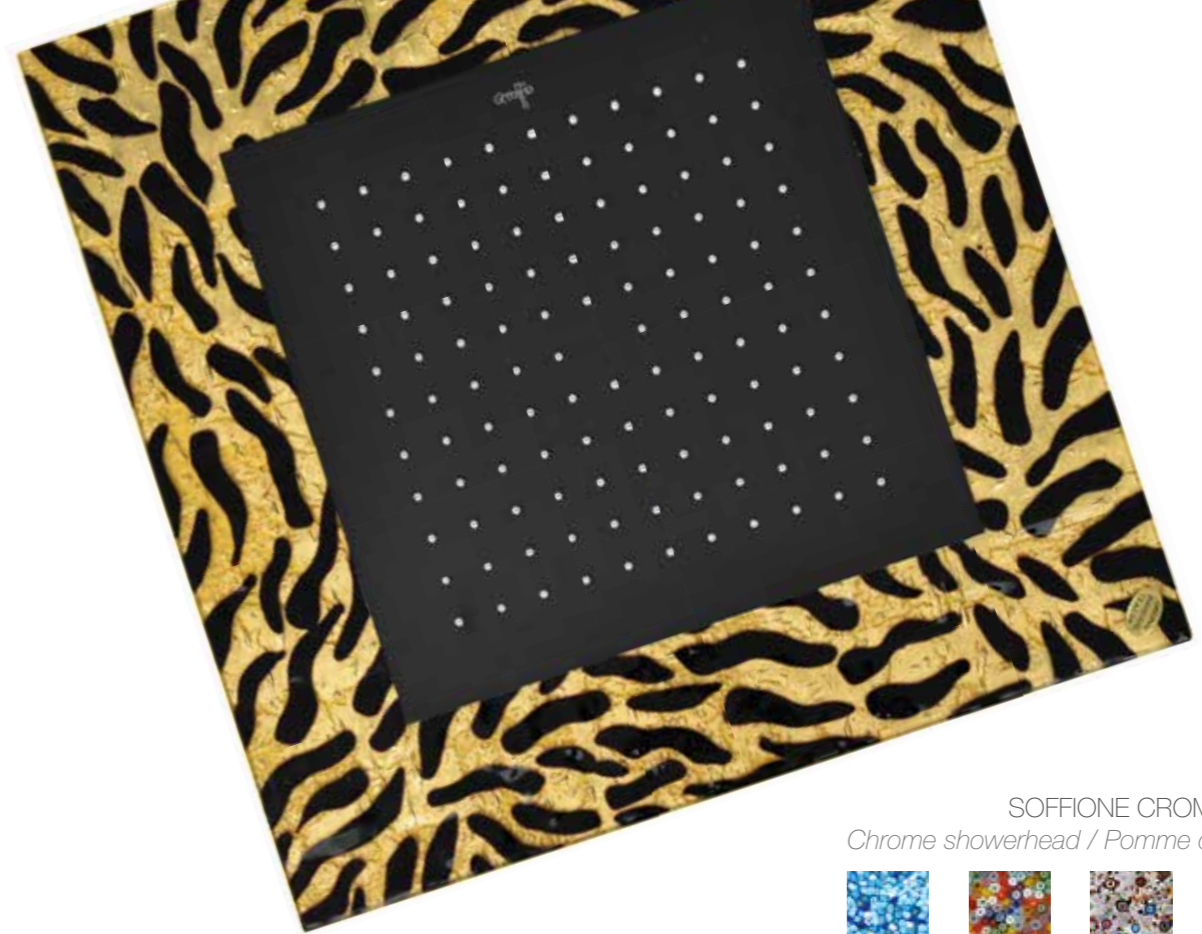

Soffione quadro LAGUNA 400x400 mm.

✓ LA 401

LAGUNA square showerhead 400x400 mm.

Pomme de douche carrée LAGUNA 400x400 mm.



VARIANTI / Variations / Variantes

- PME502 / PM110 / MA77 / MA02 / AG
- EOD191 / EO40 / ORO / NO40
- NO40 NEO / EOD191 NEO

SOFFIONE CROMO /  
Chrome showerhead / Pomme de douche chrome



PME502 PM110 MA77 MA02 AG

SOFFIONE ORO /  
Gold showerhead / Pomme de douche or



EOD191 EO40 NO40 ORO

SOFFIONE NERO OPACO /  
Matte black showerhead / Pomme de douche noire mate



EOD191 NO40

PME502 - Murrina azzurra/Light blue murrina/Murrina bleu clair PM110 - Murrina pastello/Pastel colour murrina/Murrina pastel  
MA77 - Murrina pastello-base argento/Pastel colour murrina-silver leaf/Murrina pastel-base argent  
MA02 - Murrina nera-base argento/Black murrina-silver leaf/Murrina noir-base argent EOD191 - Fantasia scura-base oro/Dark pattern-golden leaf/  
Fantaisie foncée-base or EO40 - Alga rossa-base oro/Red seaweed-golden leaf/Algue rouge-base or  
NO40 - Alga nera/Black Seaweed/Algue noire ORO - Oro/Gold/Or AG - Argento/Silver/Argent



LA 802

- 400x400 mm
- ✓ L 590 mm
- ✓ G. 1/2" M

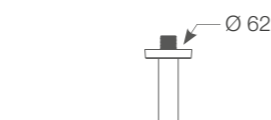

LA 804

- 400x400 mm
- ✓ H 357 mm
- ✓ G. 1/2" M

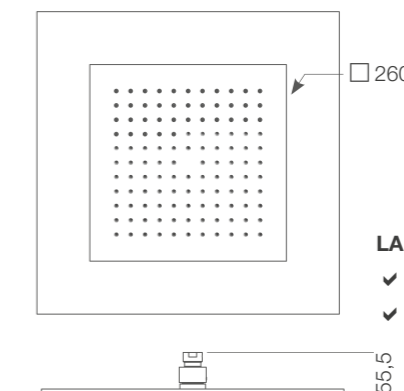

LA 401

- ✓ L/H 400 mm
- ✓ G. 1/2" F

Specchio rettangolare LAGUNA 900x600 mm.

✓ LA 920

LAGUNA rectangular mirror 900x600 mm.

Miroir rectangulaire LAGUNA 900x600 mm.



VARIANTI / Variations / Variantes

■ PME502 / PM110 / MA77 / MA02 / AG / EOD191  
EO40 / NO40 / ORO



Specchio rettangolare LAGUNA 700x500 mm.

✓ LA 975

LAGUNA rectangular mirror 700x500 mm.

Miroir rectangulaire LAGUNA 700x500 mm.



VARIANTI / Variations / Variantes

■ PME502 / PM110 / MA77 / MA02 / AG / EOD191  
EO40 / NO40 / ORO



PME502    PM110    MA77    MA02    EOD191    EO40    NO40    ORO    AG

PME502 - Murrina azzurra/Light blue murrina/Murrina bleu clair PM110 - Murrina pastello/Pastel colour murrina/Murrina pastel  
MA77 - Murrina pastello-base argento/Pastel colour murrina-silver leaf/Murrina pastel-base argent  
MA02 - Murrina nera-base argento/Black murrina-silver leaf/Murrina noir-base argent EOD191 - Fantasia scura-base oro/Dark pattern-golden leaf/  
Fantaisie foncée-base or EO40 - Alga rossa-base oro/Red seaweed-golden leaf/Algue rouge-base or  
NO40 - Alga nera/Black Seaweed/Algue noire ORO - Oro/Gold/Or AG - Argento/Silver/Argent

Il gesso e gli stucchi che hanno da sempre caratterizzato lo stile delle residenze di lusso italiane hanno ispirato la linea FRAME, che con l'utilizzo di nuovi materiali, più leggeri e maneggevoli, raggiunge sorprendenti risultati estetici.

*Chalk and rendering that have always characterised the style of luxury Italian residences, inspired the FRAME Collection that, using new and lighter materials, which are easy to apply, achieves a surprising finished result.*

*Le plâtre et les moulures qui ont toujours caractérisé les résidences de luxe italiennes, ont inspiré la collection FRAME, la quelle, en utilisant de nouveaux matériaux plus légers et plus malléables, obtient des résultats esthétiques surprenants.*

# Frame





Soffione tondo FRAME Ø 320 mm,  
braccio doccia tondo 350 mm.  
✓ FR 801

FRAME round showerhead Ø 320 mm,  
round shower arm 350 mm.

Pomme de douche ronde FRAME  
Ø 320 mm, bras mural rond 350 mm.



VARIANTI CORNICE / Frame variations /  
Variantes cadre

■ BI / ORO / AG



Soffione tondo FRAME Ø 320 mm.  
✓ FR 001

FRAME round showerhead Ø 320 mm.

Pomme de douche ronde FRAME  
Ø 320 mm.



VARIANTI CORNICE / Frame variations /  
Variantes cadre

■ BI / ORO / AG

Soffione tondo FRAME Ø 320 mm  
ad incasso.  
✓ FR 011

FRAME round built-in ceiling mounted  
showerhead Ø 320 mm.

Pomme de douche plafond ronde  
FRAME Ø 320 mm, encastrée.



VARIANTI CORNICE / Frame variations /  
Variantes cadre

■ BI / ORO / AG



BI - Bianco/White/Blanc ORO - Oro/Gold/Or AG - Argento/Silver/Argent

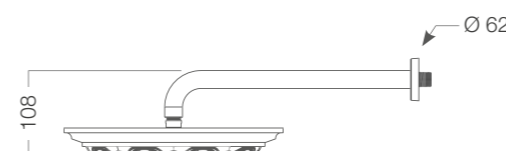

**FR 801**  
O Ø 320 mm  
✓ L 516,5 mm  
✓ G. ½" M

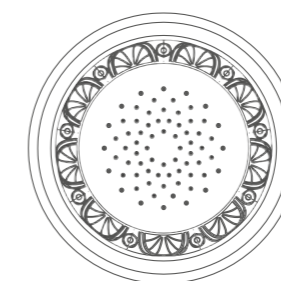

**FR 001**  
✓ Ø 320 mm  
✓ G. ½" F

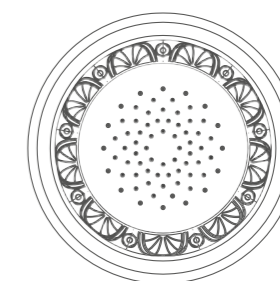

**FR 011**  
✓ Ø 320 mm  
✓ G. ½" M





Soffione tondo FRAME Ø 900 mm,  
applicazione a soffitto incasso o esterna.

✓ FR 004

FRAME round exposed ceiling mounted showerhead  
Ø 900 mm.

Pomme de douche plafond ronde FRAME Ø 900 mm,  
externe.



VARIANTI CORNICE / Frame variations / Variantes cadre

■ BI / ORO / AG

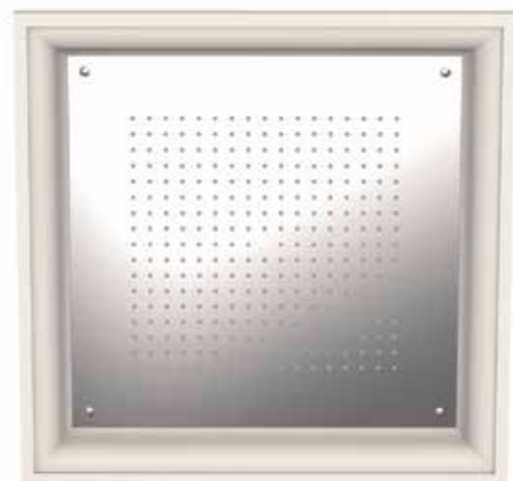

Soffione quadro FRAME 600x600 mm,  
applicazione a soffitto incasso o esterna.

✓ FR 401

FRAME square exposed or built-in ceiling mounted  
showerhead 600x600 mm.

Pomme de douche plafond carrée FRAME 600x600 mm,  
encastrée ou externe.



VARIANTI CORNICE / Frame variations / Variantes cadre

■ BI / ORO / AG



Soffione tondo FRAME Ø 750 mm ad incasso.

✓ FR 003

FRAME round built-in ceiling mounted showerhead  
Ø 750 mm.

Pomme de douche plafond ronde FRAME  
Ø 750 mm, encastrée.



VARIANTI CORNICE / Frame variations /  
Variantes cadre

■ BI / ORO / AG



Soffione tondo FRAME Ø 540 mm ad incasso.

✓ FR 012

FRAME round built-in ceiling mounted showerhead  
Ø 540 mm.

Pomme de douche plafond ronde FRAME  
Ø 540 mm, encastrée.



VARIANTI CORNICE / Frame variations /  
Variantes cadre

■ BI / ORO / AG



BI - Bianco/White/Blanc ORO - Oro/Gold/Or AG - Argento/Silver/Argent

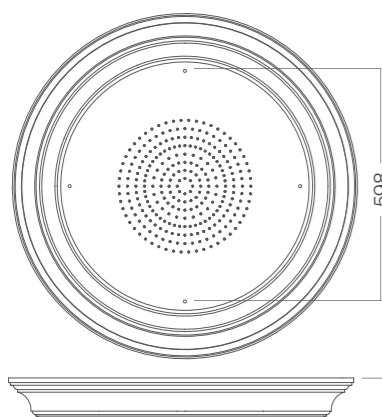

FR 004

✓ Ø 900 mm  
✓ G. 1/2" M

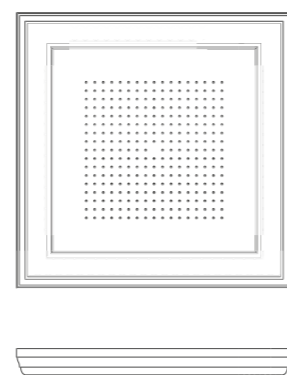

FR 401

✓ L/H 600 mm  
✓ G. 1/2" M

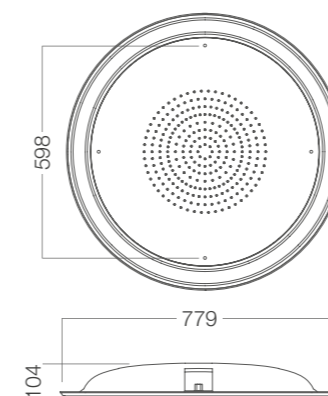

FR 003

✓ Ø 750 mm  
✓ G. 1/2" M

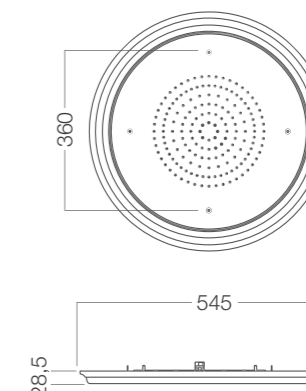

FR 012

✓ Ø 540 mm  
✓ G. 1/2" M



La tradizione decorativa barocca e l'eccellenza italiana nella produzione di tessuti pregiati hanno ispirato la creazione di ARABESQUE, soffioni doccia che riproducono i motivi e i colori di antichi ornamenti attraverso tecniche innovative e ricercate.

*The Baroque decorative tradition and the Italian excellence in the production of prestigious textiles have inspired the creation of ARABESQUE, shower heads which reproduce textile patterns and colours of the antique ornaments using brand new and sophisticated techniques.*

*La tradition décorative baroque et l'excellence italienne de la production des tissus précieux ont inspiré la création de ARABESQUE, pommes de douche qui reproduisent l'esthétique et les couleurs des antiques ornements grâce à des techniques pointues et innovatrices.*

# Arabesque





**Soffione tondo ARABESQUE  
Ø 400 mm ad incasso.**

✓ AR 014

*ARABESQUE round ceiling mounted  
showerhead Ø 400 mm.*

*Pomme de douche plafond ronde  
ARABESQUE Ø 400 mm, encastrée.*



VARIANTI / Variations / Variantes

■ ORO / AG / BL / MA / RO / VE

**Soffione tondo ARABESQUE  
Ø 500 mm ad incasso.**

✓ AR 016

*ARABESQUE round ceiling mounted  
showerhead Ø 500 mm.*

*Pomme de douche plafond ronde  
ARABESQUE Ø 500 mm, encastrée.*



VARIANTI / Variations / Variantes

■ ORO / AG / BL / MA / RO / VE

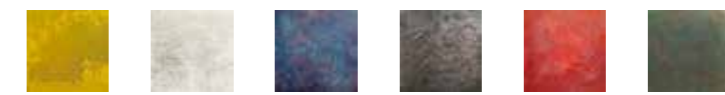

ORO    AG    BL    MA    RO    VE

ORO - Base oro/Gold base/Base or AG - Base argento/Silver base/Base argent BL - Base blu/Blue base/Base bleu  
MA - Base marrone/Brown base/Base brun RO - Base rosso/Red base/Base rouge VE - Base verde/Green base/Base vert

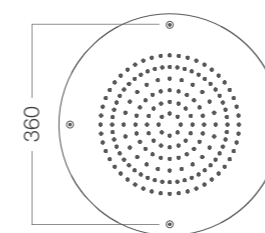

**AR 014**  
✓ Ø 400 mm  
✓ G. 1/2" M

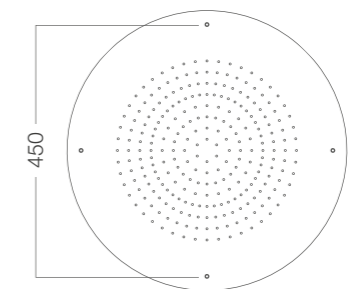
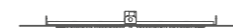

**AR 016**  
✓ Ø 500 mm  
✓ G. 1/2" M



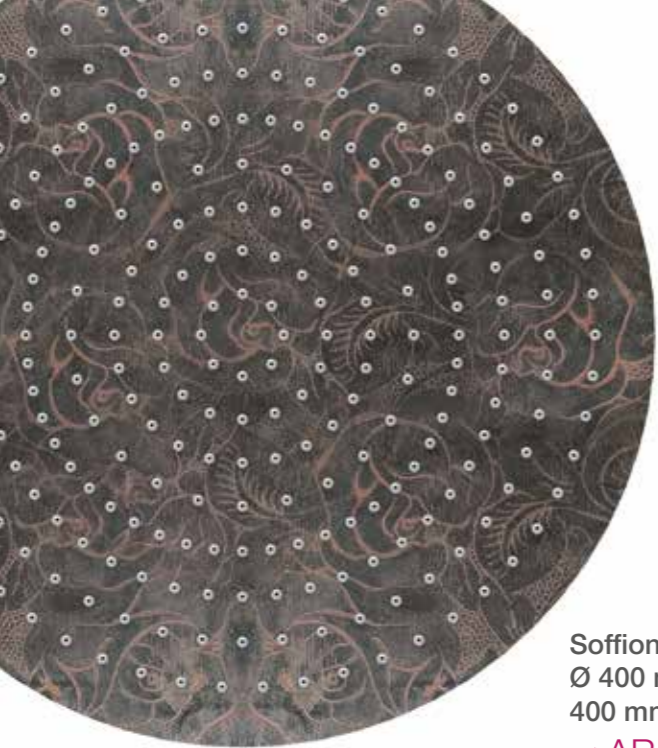

**Soffione tondo ARABESQUE**  
Ø 400 mm.

✓ AR 004

ARABESQUE round showerhead  
Ø 400 mm.

Pomme de douche ronde  
ARABESQUE Ø 400 mm.



VARIANTI / Variations / Variantes  
■ ORO / AG / BL / MA / RO / VE

**Soffione tondo ARABESQUE**  
Ø 400 mm, braccio doccia tondo  
400 mm.

✓ AR 804

ARABESQUE round showerhead  
Ø 400 mm, round shower arm  
400 mm.

Pomme de douche ronde  
ARABESQUE Ø 400 mm, bras mural  
rond 400 mm.



VARIANTI / Variations / Variantes  
■ ORO / AG / BL / MA / RO / VE



**Soffione tondo ARABESQUE**  
Ø 400 mm, braccio doccia tondo  
300 mm, attacco a soffitto.

✓ AR 814

ARABESQUE round showerhead  
Ø 400 mm, round ceiling shower arm  
300 mm.

Pomme de douche ronde  
ARABESQUE Ø 400 mm, bras plafond  
rond 300 mm.



VARIANTI / Variations / Variantes  
■ ORO / AG / BL / MA / RO / VE

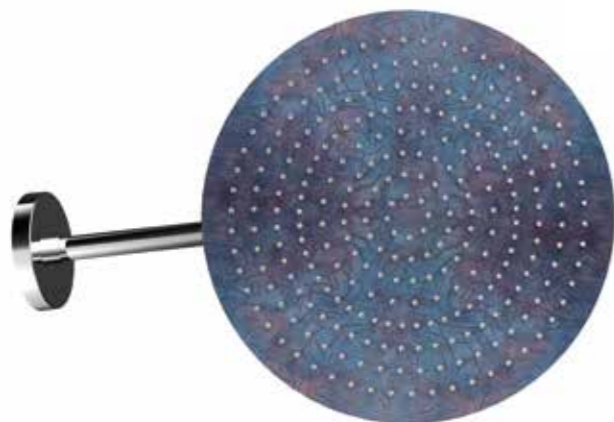

**Soffione quadro ARABESQUE**  
400x400 mm ad incasso.

✓ AR 414

ARABESQUE square ceiling mounted  
showerhead 400x400 mm.

Pomme de douche plafond carrée  
ARABESQUE 400x400 mm, encastrée.



VARIANTI / Variations / Variantes  
■ ORO / AG / BL / MA / RO / VE

**Soffione quadro ARABESQUE**  
500x500 mm ad incasso.

✓ AR 416

ARABESQUE square ceiling mounted  
showerhead 500x500 mm.

Pomme de douche plafond carrée  
ARABESQUE 500x500 mm, encastrée.



VARIANTI / Variations / Variantes  
■ ORO / AG / BL / MA / RO / VE



ORO AG BL MA RO VE

ORO - Base oro/Gold base/Base or AG - Base argento/Silver base/Base argent BL - Base blu/Blue base/Base bleu  
MA - Base marrone/Brown base/Base brun RO - Base rosso/Red base/Base rouge VE - Base verde/Green base/Base vert

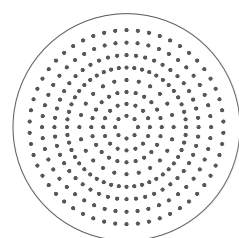

**AR 004**  
✓ Ø 400 mm  
✓ G. 1/2" F



**AR 804**  
O Ø 400 mm  
✓ L 590 mm  
✓ G. 1/2" M

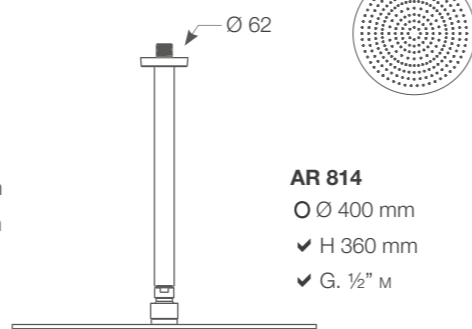

**AR 814**  
O Ø 400 mm  
✓ H 360 mm  
✓ G. 1/2" M

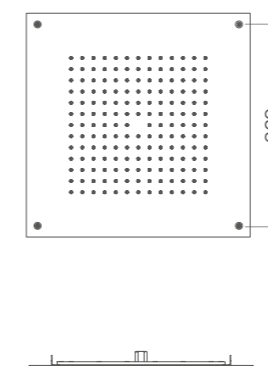

**AR 414**  
✓ L/H 400 mm  
✓ G. 1/2" M

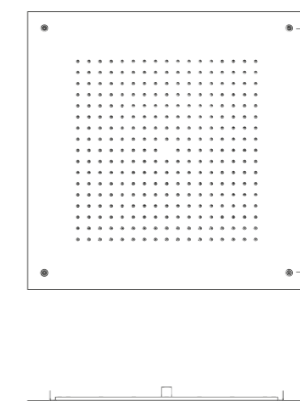

**AR 416**  
✓ L/H 500 mm  
✓ G. 1/2" M

Soffione rettangolare ARABESQUE 600x400 mm ad incasso.

✓ AR 201

ARABESQUE rectangular ceiling mounted showerhead 600x400 mm.

Pomme de douche à plafond rectangulier ARABESQUE 600x400 mm, encastrée.



VARIANTI / Variations / Variantes  
 ■ ORO / AG / BL / MA / RO / VE

Soffione rettangolare ARABESQUE 600x400 mm ad incasso, 6 nebulizzatori.

✓ AR 221

ARABESQUE rectangular ceiling mounted showerhead 600x400 mm, 6 mist sprays.

Pomme de douche à plafond rectangulier ARABESQUE 600x400 mm, encastrée, 6 jets brumiseurs.



VARIANTI / Variations / Variantes  
 ■ ORO / AG / BL / MA / RO / VE

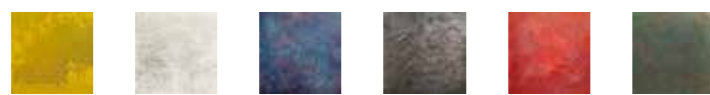

ORO - Base oro/Gold base/Base or AG - Base argento/Silver base/Base argent BL - Base blu/Blue base/Base bleu MA - Base marrone/Brown base/Base brun RO - Base rosso/Red base/Base rouge VE - Base verde/Green base/Base vert

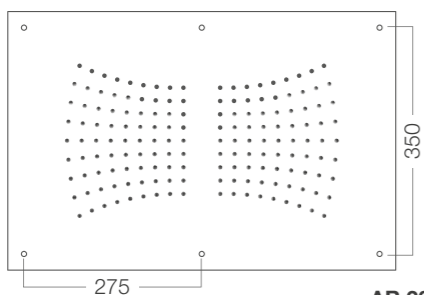

AR 201

✓ L 600x400 mm  
 ✓ G. 1/2" M

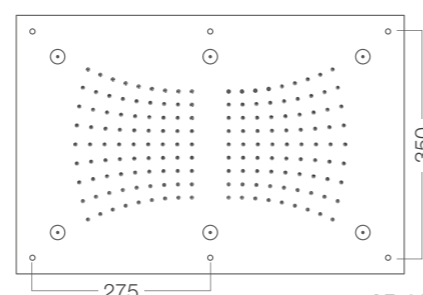
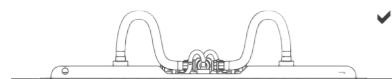

AR 221

✓ L 600x400 mm  
 ✓ G. 1/2" M

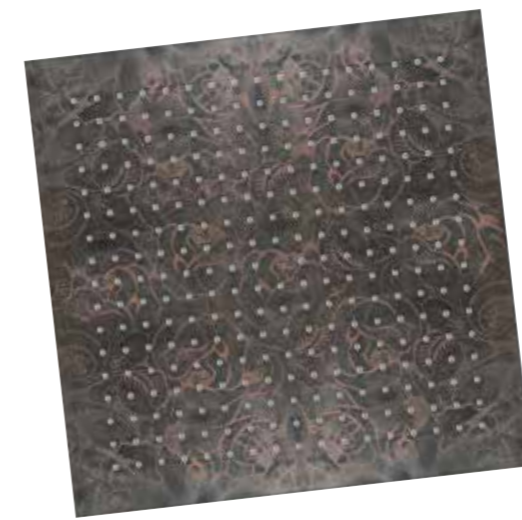
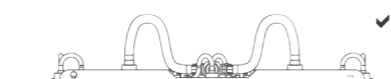

Soffione quadro ARABESQUE 400x400 mm.

✓ AR 404

ARABESQUE square showerhead 400x400 mm.

Pomme de douche carrée ARABESQUE 400x400 mm.



VARIANTI / Variations / Variantes  
 ■ ORO / AG / BL / MA / RO / VE

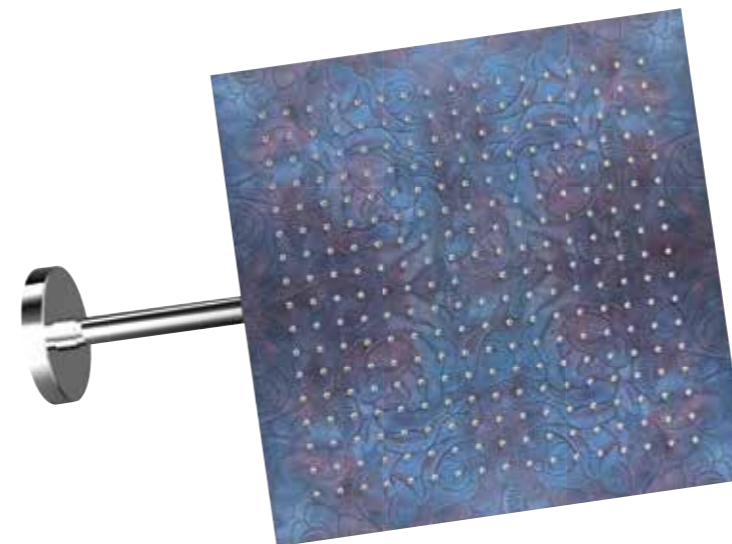

Soffione quadro ARABESQUE 400x400 mm, braccio doccia quadro 300 mm, attacco a soffitto.

✓ AR 854

ARABESQUE square showerhead 400x400 mm, square ceiling mounted shower arm 300 mm.

Pomme de douche carrée ARABESQUE 400x400 mm, bras plafond carré 300 mm.



VARIANTI / Variations / Variantes  
 ■ ORO / AG / BL / MA / RO / VE

Soffione quadro ARABESQUE 400x400 mm, braccio doccia tondo 400 mm.

✓ AR 844

ARABESQUE square showerhead 400x400 mm, round shower arm 400 mm.

Pomme de douche carrée ARABESQUE 400x400 mm, bras mural rond 400 mm.



VARIANTI / Variations / Variantes  
 ■ ORO / AG / BL / MA / RO / VE

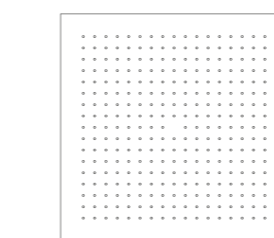

AR 404

✓ L/H 400 mm  
 ✓ G. 1/2" F



AR 844

□ 400x400 mm  
 ✓ L 590 mm  
 ✓ G. 1/2" M

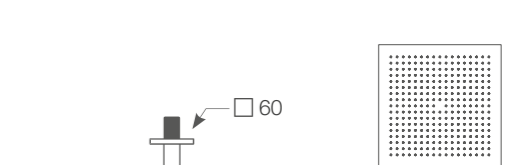
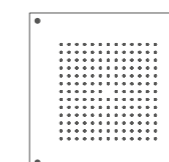

AR 854

□ 400x400 mm  
 ✓ L 360 mm  
 ✓ G. 1/2" M

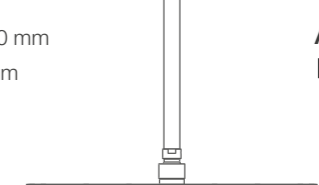

L'arte della lavorazione della pelle e del cuoio è l'ispirazione della collezione SKIN, che riproduce l'estetica del rivestimento in pelle, con materiali innovativi e altamente resistenti, in diversi colori.

*The art of working with skins and leather, inspired the SKIN collection, which reproduces the esthetical effect of leather finishing utilising innovative materials, highly resistant and available in various colours.*

*L'art de travailler la peau et le cuire a inspiré la collection SKIN, qui propose, grâce à des matériaux innovants hautement résistants, l'esthétique exclusive des revêtements en peau, disponibles en différentes versions colorées.*

# Skin





**Soffione tondo SKIN Ø 400 mm ad incasso.**

✓ SK 014

SKIN round ceiling mounted showerhead Ø 400 mm.

Pomme de douche plafond ronde SKIN Ø 400 mm, encastrée.



VARIANTI / Variations / Variantes

■ ORO / AZ / BL / MA / RO / VE

**Soffione tondo SKIN Ø 500 mm ad incasso.**

✓ SK 016

SKIN round ceiling mounted showerhead Ø 500 mm.

Pomme de douche plafond ronde SKIN Ø 500 mm, encastrée.



VARIANTI / Variations / Variantes

■ ORO / AZ / BL / MA / RO / VE

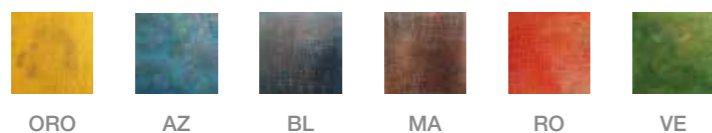

ORO - Base oro/Gold base/Base or AZ - Base azzurro/Light blue base/Base azur BL - Base blu/Blue base/Base bleu MA - Base marrone/Brown base/Base brun RO - Base rosso/Red base/Base rouge VE - Base verde/Green base/Base vert

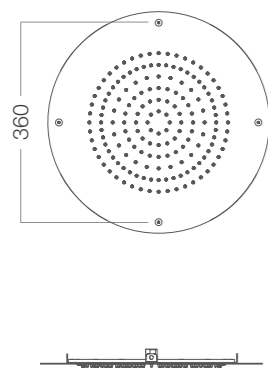

**SK 014**  
✓ Ø 400 mm  
✓ G. ½" M

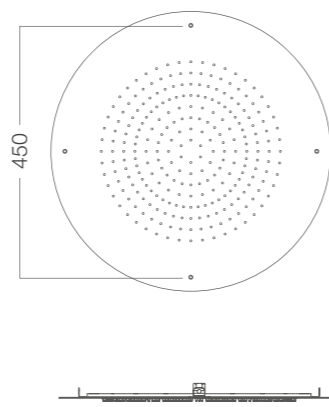

**SK 016**  
✓ Ø 500 mm  
✓ G. ½" M

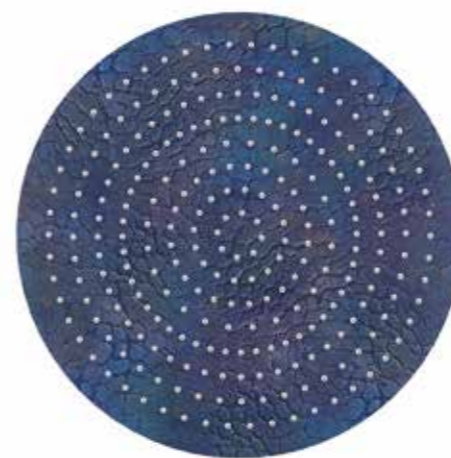

**Soffione tondo SKIN Ø 400 mm.**

✓ SK 004

SKIN round showerhead Ø 400 mm.

Pomme de douche ronde SKIN Ø 400 mm.



VARIANTI / Variations / Variantes

■ ORO / AZ / BL / MA / RO / VE

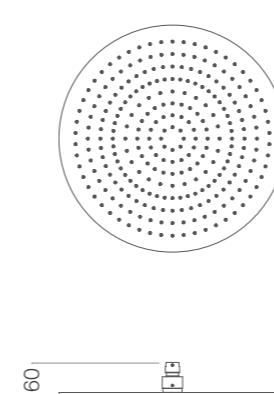

**SK 004**  
✓ Ø 400 mm  
✓ G. ½" F

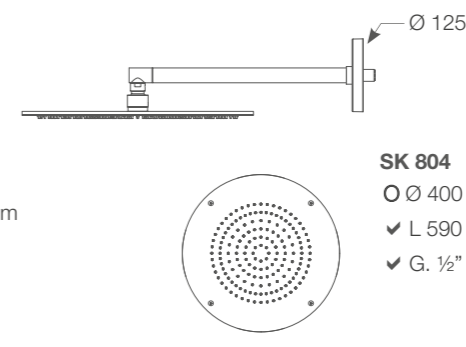

**SK 804**  
O Ø 400 mm  
✓ L 590 mm  
✓ G. ½" M



**Soffione tondo SKIN Ø 400 mm, braccio doccia tondo 300 mm, attacco a soffitto.**

✓ SK 814

SKIN round showerhead Ø 400 mm, round ceiling mounted shower arm 300 mm.

Pomme de douche ronde SKIN Ø 400 mm, bras plafond rond 300 mm.



VARIANTI / Variations / Variantes

■ ORO / AZ / BL / MA / RO / VE

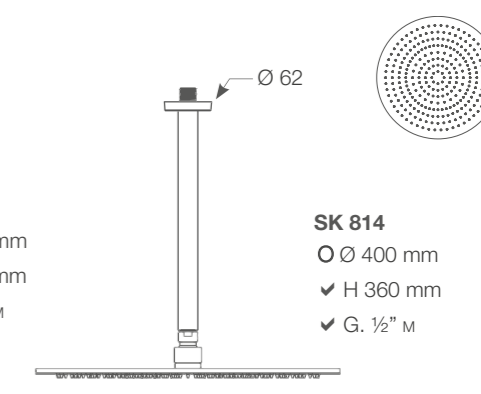

**SK 814**  
O Ø 400 mm  
✓ H 360 mm  
✓ G. ½" M



**Soffione quadro SKIN 400x400 mm  
ad incasso.**

✓ **SK 414**

*SKIN square ceiling mounted  
showerhead 400x400 mm.*

*Pomme de douche plafond carrée SKIN  
400x400 mm, encastrée.*



VARIANTI / Variations / Variantes

■ **ORO / AZ / BL / MA / RO / VE**

**Soffione quadro SKIN 500x500 mm  
ad incasso.**

✓ **SK 416**

*SKIN square ceiling mounted  
showerhead 500x500 mm.*

*Pomme de douche plafond carrée SKIN  
500x500 mm, encastrée.*



VARIANTI / Variations / Variantes

■ **ORO / AZ / BL / MA / RO / VE**

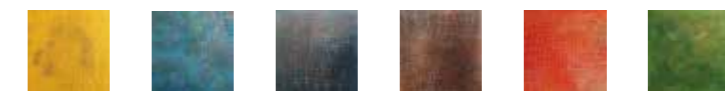
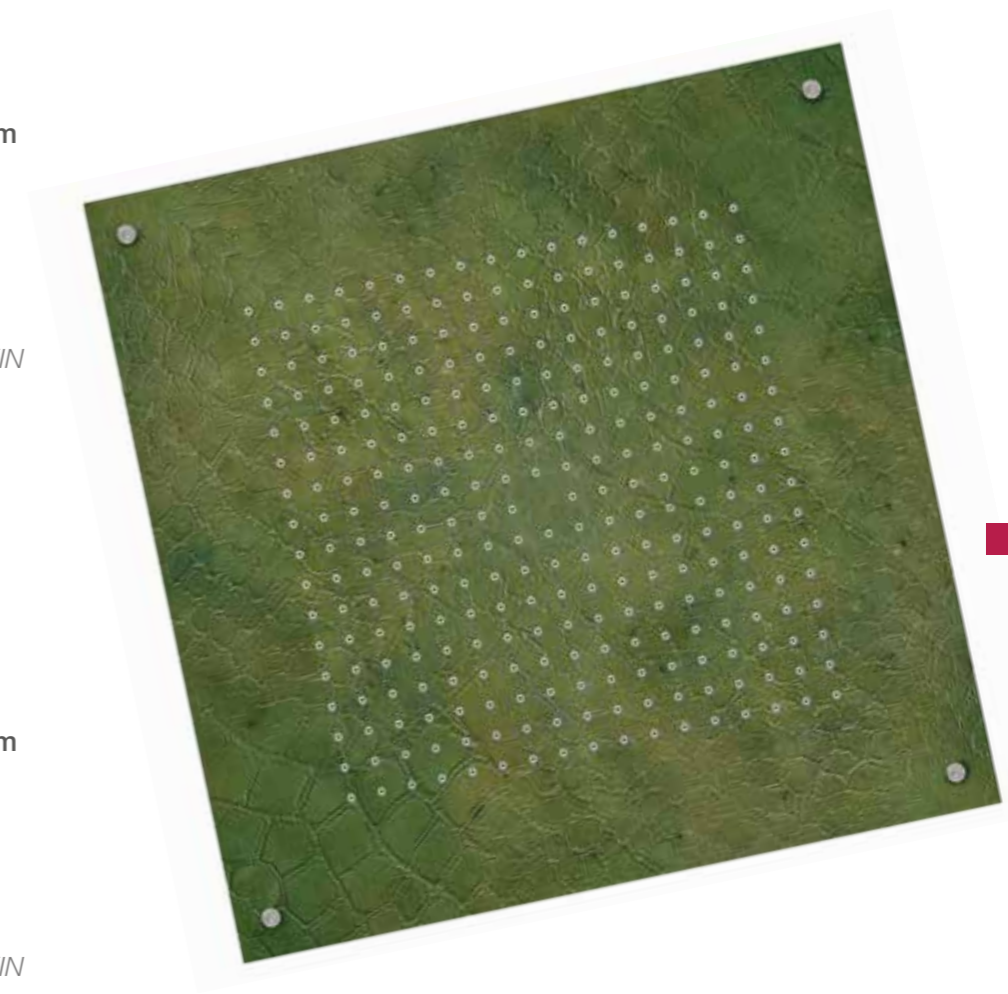

ORO    AZ    BL    MA    RO    VE

ORO - Base oro/Gold base/Base or    AZ - Base azzurro/Light blue base/Base azur    BL - Base blu/Blue base/Base bleu  
MA - Base marrone/Brown base/Base brun    RO - Base rosso/Red base/Base rouge    VE - Base verde/Green base/Base vert

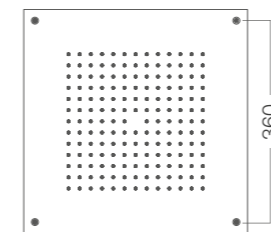

**SK 414**

✓ L/H 400 mm  
✓ G. 1/2" M

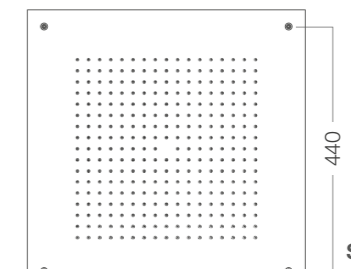

**SK 416**

✓ L/H 500 mm  
✓ G. 1/2" M



**Soffione rettangolare SKIN  
600x400 mm ad incasso.**

✓ SK 201

SKIN rectangular ceiling mounted  
showerhead 600x400 mm.

Pomme de douche à plafond  
rectangulier SKIN  
600x400 mm, encastrée.



VARIANTI / Variations / Variantes

■ ORO / AZ / BL / MA / RO / VE

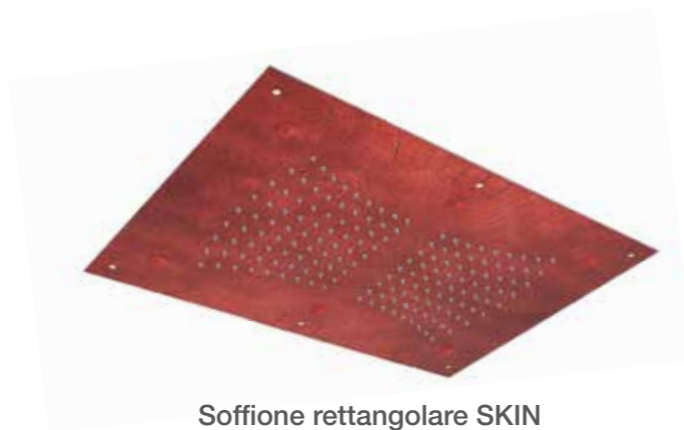

**Soffione rettangolare SKIN  
600x400 mm ad incasso,  
6 nebulizzatori.**

✓ SK 221

SKIN rectangular ceiling mounted  
showerhead 600x400 mm,  
6 mist sprays.

Pomme de douche à plafond  
rectangulier SKIN 600x400 mm,  
encastrée, 6 jets brumiseurs.



VARIANTI / Variations / Variantes

■ ORO / AZ / BL / MA / RO / VE

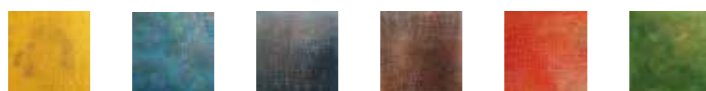
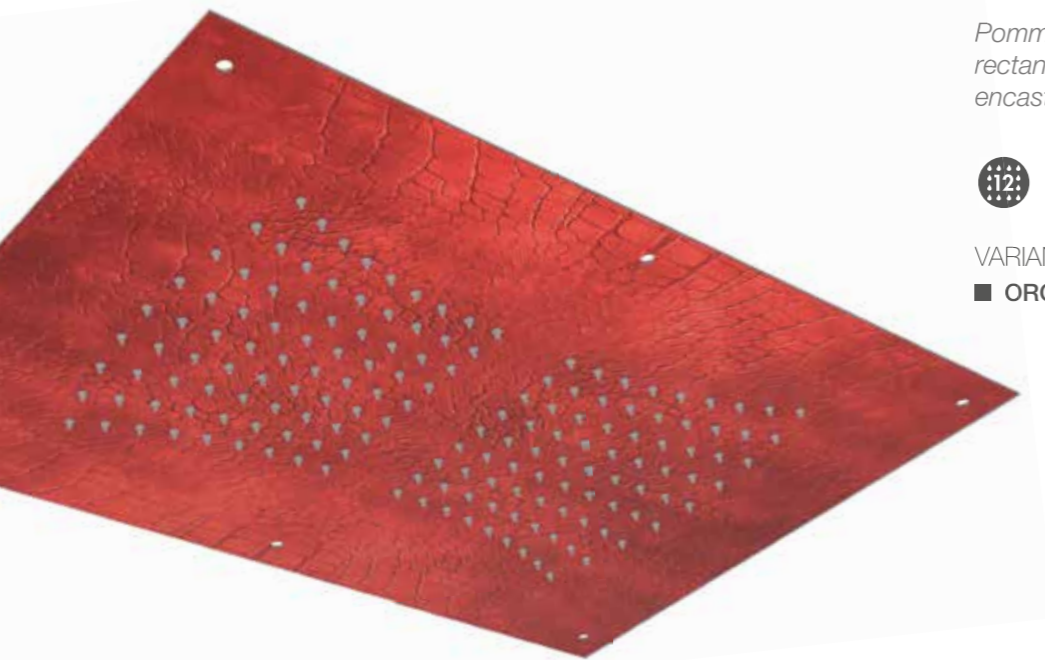

ORO AZ BL MA RO VE

ORO - Base oro/Gold base/Base or AZ - Base azzurro/Light blue base/Base azur BL - Base blu/Blue base/Base bleu  
MA - Base marrone/Brown base/Base brun RO - Base rosso/Red base/Base rouge VE - Base verde/Green base/Base vert

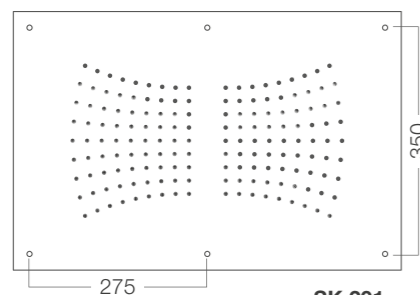

**SK 201**

- ✓ L 600x400 mm
- ✓ G. 1/2" M

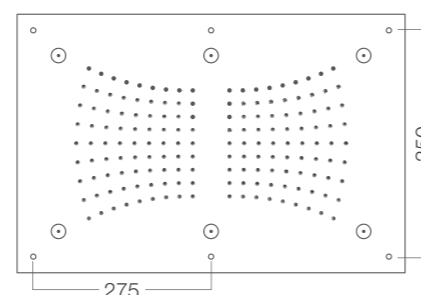
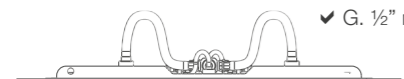

**SK 221**

- ✓ L 600x400 mm
- ✓ G. 1/2" M

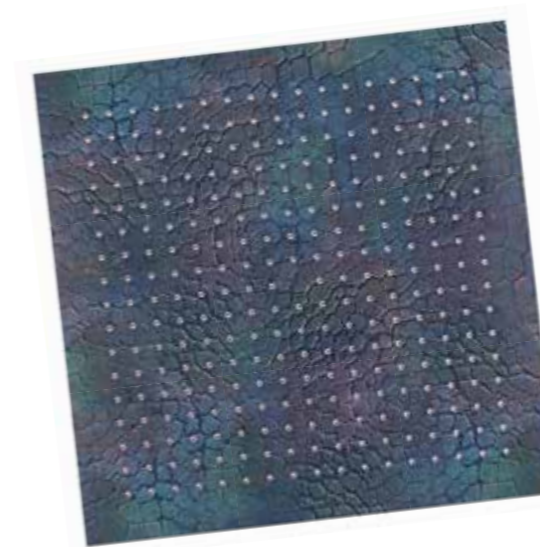
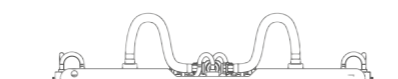

**Soffione quadro SKIN 400x400 mm.**

✓ SK 404

SKIN square showerhead 400x400 mm.

Pomme de douche carrée SKIN 400x400 mm.



VARIANTI / Variations / Variantes

■ ORO / AZ / BL / MA / RO / VE

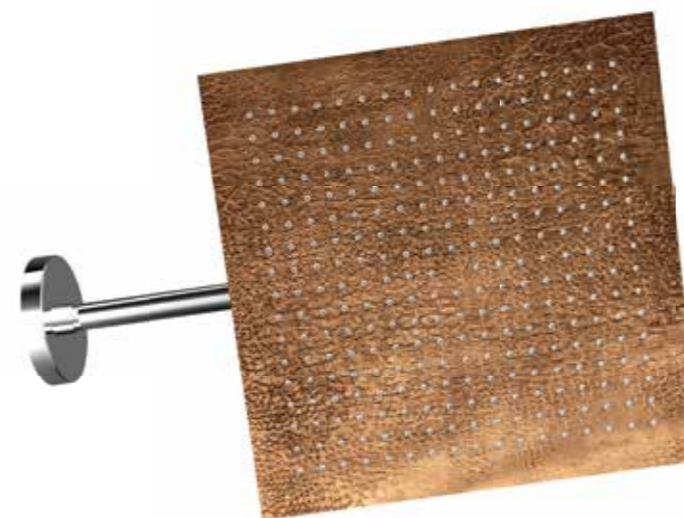

**SK 404**

- ✓ L/H 400 mm
- ✓ G. 1/2" F



**SK 844**

- 400x400 mm
- ✓ L 590 mm
- ✓ G. 1/2" M

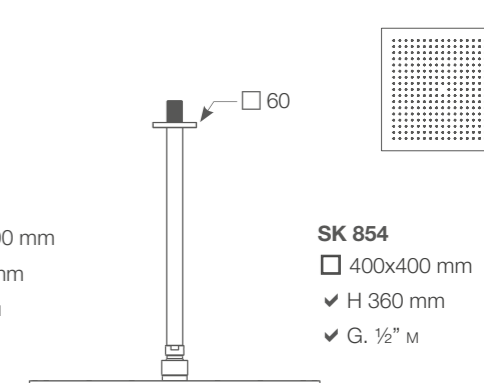
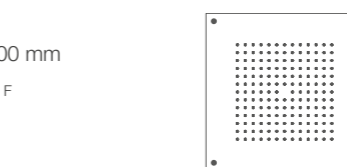

**SK 854**

- 400x400 mm
- ✓ H 360 mm
- ✓ G. 1/2" M

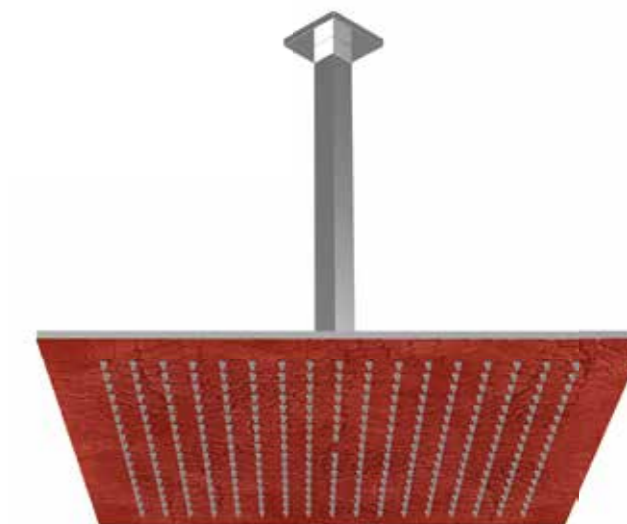

**Soffione quadro SKIN 400x400 mm,  
braccio doccia quadro 300 mm, attacco a soffitto.**

✓ SK 854

SKIN square showerhead 400x400 mm,  
square ceiling mounted shower arm 300 mm.

Pomme de douche carrée SKIN 400x400 mm,  
bras plafond carré 300 mm.



VARIANTI / Variations / Variantes

■ ORO / AZ / BL / MA / RO / VE

**Soffione quadro SKIN 400x400 mm,  
braccio doccia tondo 400 mm.**

✓ SK 844

SKIN square showerhead 400x400 mm,  
round shower arm 400 mm.

Pomme de douche carrée SKIN 400x400 mm,  
bras mural rond 400 mm.



VARIANTI / Variations / Variantes

■ ORO / AZ / BL / MA / RO / VE



L'originale linea MOND-RAIN permette di personalizzare il disegno dei soffioni in base alle proprie esigenze, inserendo per esempio il logo della propria attività o una fotografia.

*Original MOND-RAIN serie allow to customize shower heads picture as per own needs, for example introducing own trade logo or a photo.*

*L'originale gamme MOND-RAIN permet de personnaliser le dessin des pomme de douche selon .oles différents besoins. On peut pur exemple imprimer le logo de la propre entreprise ou une photo.*

# Mond-rain

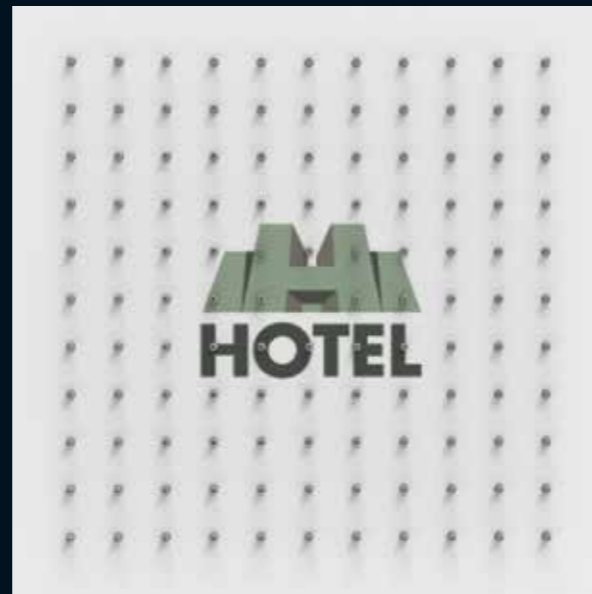
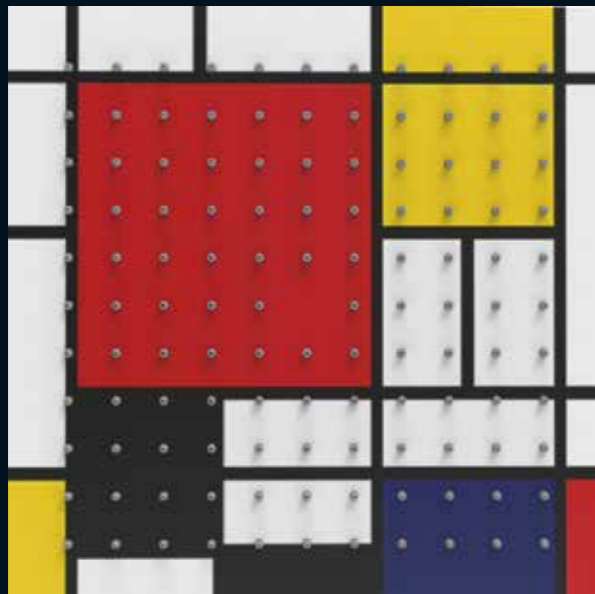

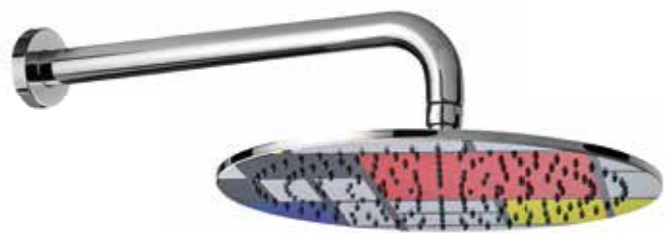

Soffione tondo MOND-RAIN Ø 240 mm, braccio doccia tondo 350 mm.

✓ MR 802

MOND-RAIN round showerhead Ø 240 mm, round shower arm 350 mm.

Pomme de douche ronde MOND-RAIN Ø 240 mm, bras mural rond 350 mm.



Soffione quadro MOND-RAIN 240x240 mm, braccio doccia tondo 350 mm, rosone quadro.

✓ MR 842

MOND-RAIN square showerhead 240x240 mm, round shower arm 350 mm, square rosette.

Pomme de douche carrée MOND-RAIN 240x240 mm, bras mural rond 350 mm, rosette carrée.



Soffione tondo MOND-RAIN Ø 240 mm, braccio doccia tondo 300 mm attacco a soffitto.

✓ MR 812

MOND-RAIN round showerhead Ø 240 mm, round ceiling mounted shower arm 300 mm.

Pomme de douche ronde MOND-RAIN Ø 240 mm, bras plafond rond 300 mm.



Soffione quadro MOND-RAIN 240x240 mm, braccio doccia tondo 300 mm attacco a soffitto, rosone quadro.

✓ MR 852

MOND-RAIN square showerhead 240x240 mm, round ceiling mounted shower arm 300 mm, square rosette.

Pomme de douche carrée MOND-RAIN 240x240 mm, bras plafond rond 300 mm, rosette carrée.



Soffione tondo MOND-RAIN Ø 300 mm, braccio doccia tondo 350 mm.

✓ MR 803

MOND-RAIN round showerhead Ø 300 mm, round shower arm 350 mm.

Pomme de douche ronde MOND-RAIN Ø 300 mm, bras mural rond 350 mm.



Soffione quadro MOND-RAIN 300x300 mm, braccio doccia tondo 350 mm, rosone quadro.

✓ MR 843

MOND-RAIN square showerhead 300x300 mm, round shower arm 350 mm, square rosette.

Pomme de douche carrée MOND-RAIN 300x300 mm, bras mural rond 350 mm, rosette carrée.



Soffione tondo MOND-RAIN Ø 300 mm, braccio doccia tondo 300 mm attacco a soffitto.

✓ MR 813

MOND-RAIN round showerhead Ø 300 mm, round ceiling mounted shower arm 300 mm.

Pomme de douche ronde MOND-RAIN Ø 300 mm, bras plafond rond 300 mm.



Soffione quadro MOND-RAIN 300x300 mm, braccio doccia tondo 300 mm attacco a soffitto, rosone quadro.

✓ MR 853

MOND-RAIN square showerhead 300x300 mm, round ceiling mounted shower arm 300 mm, square rosette.

Pomme de douche carrée MOND-RAIN 300x300 mm, bras plafond rond 300 mm, rosette carrée.



**MR 802**

- Ø 240 mm
- ✓ Ø 26 mm
- ✓ L 477 mm
- ✓ G. 1/2" M

**MR 803**

- Ø 300 mm
- ✓ Ø 26 mm
- ✓ L 507 mm
- ✓ G. 1/2" M



**MR 842**

- 240x240 mm
- ✓ Ø 20 mm
- ✓ L 472 mm
- ✓ G. 1/2" M

**MR 843**

- 300x300 mm
- ✓ Ø 20 mm
- ✓ L 502 mm
- ✓ G. 1/2" M

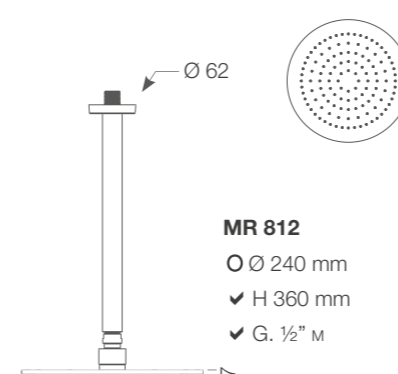

**MR 812**

- Ø 240 mm
- ✓ H 360 mm
- ✓ G. 1/2" M

**MR 813**

- Ø 300 mm
- ✓ H 360 mm
- ✓ G. 1/2" M

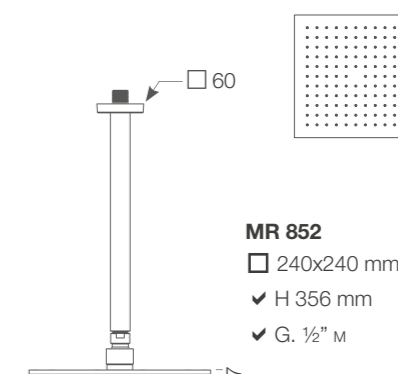

**MR 852**

- 240x240 mm
- ✓ H 356 mm
- ✓ G. 1/2" M

**MR 853**

- 300x300 mm
- ✓ H 356 mm
- ✓ G. 1/2" M



Soffione tondo MOND-RAIN Ø 240 mm.

✓ MR 002

MOND-RAIN round showerhead Ø 240 mm.

Pomme de douche ronde MOND-RAIN Ø 240 mm.



Soffione tondo MOND-RAIN Ø 300 mm.

✓ MR 003

MOND-RAIN round showerhead Ø 300 mm.

Pomme de douche ronde MOND-RAIN Ø 300 mm.



Soffione quadro MOND-RAIN 240x240 mm.

✓ MR 402

MOND-RAIN square showerhead 240x240 mm.

Pomme de douche carrée MOND-RAIN  
240x240 mm.



Soffione quadro MOND-RAIN 300x300 mm.

✓ MR 403

MOND-RAIN square showerhead 300x300 mm.

Pomme de douche carrée MOND-RAIN  
300x300 mm.

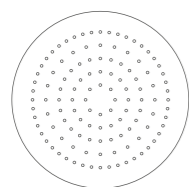

**MR 002**

- ✓ Ø 240 mm
- ✓ G. 1/2" F

**MR 003**

- ✓ Ø 300 mm
- ✓ G. 1/2" F

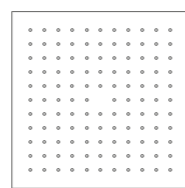

**MR 402**

- ✓ L/H 240 mm
- ✓ G. 1/2" F

**MR 403**

- ✓ L/H 300 mm
- ✓ G. 1/2" F



La collezione GIPZY si identifica per alcune caratteristiche uniche: tutti gli articoli sono cromati per ottenere una maggiore resistenza, completamente ispezionabili, facili da mantenere e dotati di bracci ad alta portata di peso in grado di garantire un fissaggio sicuro, anche dei soffioni più grandi, senza compromessi.

*GIPZY collection stands out by some unique characteristics: all items are chromed in order to obtain more resistance, they are completely inspectable, easy to care and provided with high load capacity granting a secure fixing with no damages even for the greatest ones.*

*La collection GIPZY est identifiée de certaines caractéristiques uniques : tous les articles sont chromés afin d'obtenir une meilleure résistance, complètement examinables à l'intérieur, de facile manutention, équipés des bras à haute capacité de charge pour garantir une fixation en sécurité, sans compromises, aussi pour les pommes de douches les plus grands.*

# Gipzy





Soffione tondo GIPZY Ø 240 mm,  
braccio doccia tondo 350 mm.

✓ GY 802

GIPZY round showerhead Ø 240 mm,  
round shower arm 350 mm.

Pomme de douche ronde GIPZY  
Ø 240 mm, bras mural rond 350 mm.



VARIANTI / Variations / Variantes

■ ORO / BS / RS / ORO-R / NS / NEO  
/ BIO / GG / CR



Soffione tondo GIPZY Ø 300 mm,  
braccio doccia tondo 350 mm.

✓ GY 803

GIPZY round showerhead Ø 300 mm,  
round shower arm 350 mm.

Pomme de douche ronde GIPZY  
Ø 300 mm, bras mural rond 350 mm.



VARIANTI / Variations / Variantes

■ ORO / BS / RS / ORO-R / NS / NEO  
/ BIO / GG / CR

Soffione tondo GIPZY Ø 400 mm,  
braccio doccia tondo 400 mm.

✓ GY 805

GIPZY round showerhead Ø 400 mm,  
round shower arm 400 mm.

Pomme de douche ronde GIPZY  
Ø 400 mm, bras mural rond 400 mm.



VARIANTI / Variations / Variantes

■ ORO / BS / RS / ORO-R / NS / NEO  
/ BIO / GG / CR



Soffione quadro GIPZY  
400x400 mm, braccio doccia  
tondo 400 mm, rosone tondo.

✓ GY 845

GIPZY square showerhead  
400x400 mm, round shower arm  
400 mm, round rosette.

Pomme de douche carrée GIPZY  
400x400 mm, bras mural rond  
400 mm, rosette ronde.



VARIANTI / Variations / Variantes

■ ORO / BS / RS / ORO-R / NS / NEO  
/ BIO / GG / CR



Soffione quadro GIPZY  
240x240 mm, braccio doccia  
tondo 350 mm, rosone quadro.

✓ GY 842

GIPZY square showerhead  
240x240 mm, round shower arm  
350 mm, square rosette.

Pomme de douche carrée GIPZY  
240x240 mm, bras mural rond  
350 mm, rosette carrée.



VARIANTI / Variations / Variantes

■ ORO / BS / RS / ORO-R / NS / NEO  
/ BIO / GG / CR

Soffione quadro GIPZY  
300x300 mm, braccio doccia  
tondo 350 mm, rosone quadro.

✓ GY 843

GIPZY square showerhead  
300x300 mm, round shower arm  
350 mm, square rosette.

Pomme de douche carrée GIPZY  
300x300 mm, bras mural rond  
350 mm, rosette carrée.



VARIANTI / Variations / Variantes

■ ORO / BS / RS / ORO-R / NS / NEO  
/ BIO / GG / CR

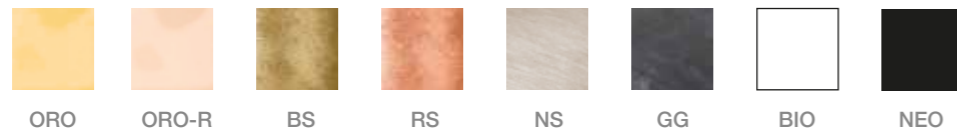

ORO

ORO-R

BS

RS

NS

GG

BIO

NEO

ORO - Oro/Gold/Or ORO-R - Oro rosa/Rose gold/Or rose

BS - Bronzo spazzolato/Brushed brass/Laiton brossé RS - Rame spazzolato/Brushed copper/Cuivre brossé

NS - Nickel spazzolato/Brushed nickel/Nickel brossé GG - Grafite/Graphite CR - Cromo/Chrome

BIO - Bianco opaco/Matte white/Blanche mate NEO - Nero opaco/Matte black/Noire mate



GY 802

Ø Ø 240 mm  
✓ Ø 26 mm  
✓ L 477 mm  
✓ G. 1/2" M



GY 803

Ø Ø 300 mm  
✓ Ø 26 mm  
✓ L 507 mm  
✓ G. 1/2" M

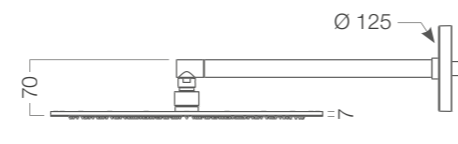

GY 805

Ø Ø 400 mm  
✓ Ø 25,6 mm  
✓ L 590 mm  
✓ G. 1/2" M

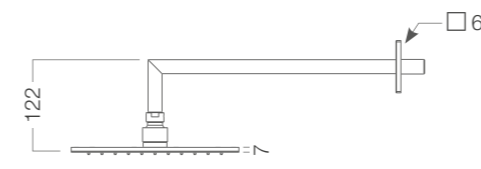

GY 842

□ 240x240 mm  
✓ Ø 20 mm  
✓ L 472 mm  
✓ G. 1/2" M

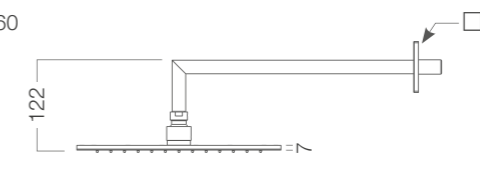

GY 843

□ 300x300 mm  
✓ Ø 20 mm  
✓ L 502 mm  
✓ G. 1/2" M

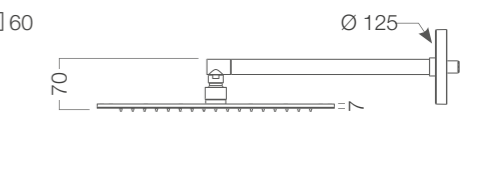

GY 845

□ 400x400 mm  
✓ Ø 25,6 mm  
✓ L 590 mm  
✓ G. 1/2" M

Soffione tondo GIPZY Ø 240 mm,  
braccio doccia tondo 300 mm attacco a soffitto.

✓ GY 812

GIPZY round showerhead Ø 240 mm,  
round ceiling mounted shower arm 300 mm.

Pomme de douche ronde GIPZY  
Ø 240 mm, bras plafond rond 300 mm.



VARIANTI / Variations / Variantes

■ ORO / BS / RS / ORO-R / NS / NEO  
/ BIO / GG / CR



Soffione tondo GIPZY Ø 300 mm,  
braccio doccia tondo 300 mm attacco a soffitto.

✓ GY 813

GIPZY round showerhead Ø 300 mm,  
round ceiling mounted shower arm 300 mm.

Pomme de douche ronde GIPZY Ø 300 mm,  
bras plafond rond 300 mm.



VARIANTI / Variations / Variantes

■ ORO / BS / RS / ORO-R / NS / NEO  
/ BIO / GG / CR

Soffione tondo GIPZY Ø 400 mm,  
braccio doccia tondo 300 mm attacco a soffitto.

✓ GY 815

GIPZY round showerhead Ø 400 mm,  
round ceiling mounted shower arm 300 mm.

Pomme de douche ronde GIPZY  
Ø 400 mm, bras plafond rond 300 mm.



VARIANTI / Variations / Variantes

■ ORO / BS / RS / ORO-R / NS / NEO  
/ BIO / GG / CR



Soffione quadro GIPZY 400x400 mm, braccio doccia  
tondo 300 mm attacco a soffitto, rosone quadro.

✓ GY 855

GIPZY square showerhead 400x400 mm, round ceiling  
mounted shower arm 300 mm, square rosette.

Pomme de douche carrée GIPZY 400x400 mm,  
bras plafond rond 300 mm, rosette carrée.



VARIANTI / Variations / Variantes

■ ORO / BS / RS / ORO-R / NS / NEO  
/ BIO / GG / CR

Soffione quadro GIPZY 240x240 mm, braccio doccia  
tondo 300 mm attacco a soffitto, rosone quadro.

✓ GY 852

GIPZY square showerhead 240x240 mm, round  
ceiling mounted shower arm 300 mm, square rosette.

Pomme de douche carrée GIPZY 240x240 mm,  
bras plafond rond 300 mm, rosette carrée.



VARIANTI / Variations / Variantes

■ ORO / BS / RS / ORO-R / NS / NEO  
/ BIO / GG / CR

Soffione quadro GIPZY 300x300 mm, braccio doccia  
tondo 300 mm attacco a soffitto, rosone quadro.

✓ GY 853

GIPZY square showerhead 300x300 mm, round ceiling  
mounted shower arm 300 mm, square rosette.

Pomme de douche carrée GIPZY 300x300 mm,  
bras plafond rond 300 mm, rosette carrée.



VARIANTI / Variations / Variantes

■ ORO / BS / RS / ORO-R / NS / NEO  
/ BIO / GG / CR

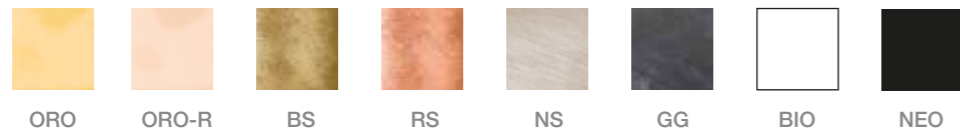

ORO - Oro/Gold/Or ORO-R - Oro rosa/Rose gold/Or rose

BS - Bronzo spazzolato/Brushed brass/Laiton brossé RS - Rame spazzolato/Brushed copper/Cuivre brossé

NS - Nickel spazzolato/Brushed nickel/Nickel brossé GG - Grafite/Graphite CR - Cromo/Chrome

BIO - Bianco opaco/Matte white/Blanche mate NEO - Nero opaco/Matte black/Noire mate

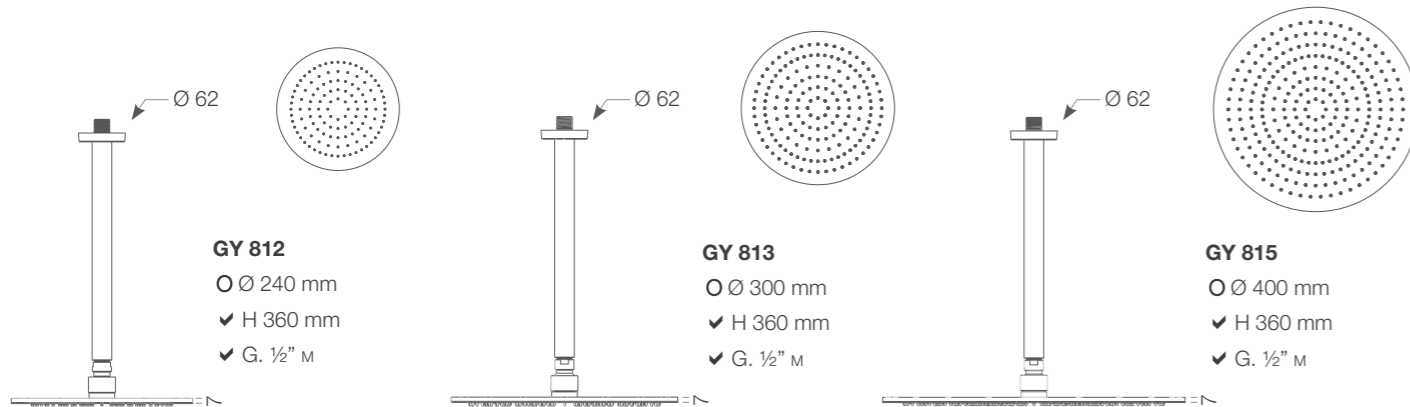

GY 812

○ Ø 240 mm  
✓ H 360 mm  
✓ G. 1/2" M

GY 813

○ Ø 300 mm  
✓ H 360 mm  
✓ G. 1/2" M

GY 815

○ Ø 400 mm  
✓ H 360 mm  
✓ G. 1/2" M

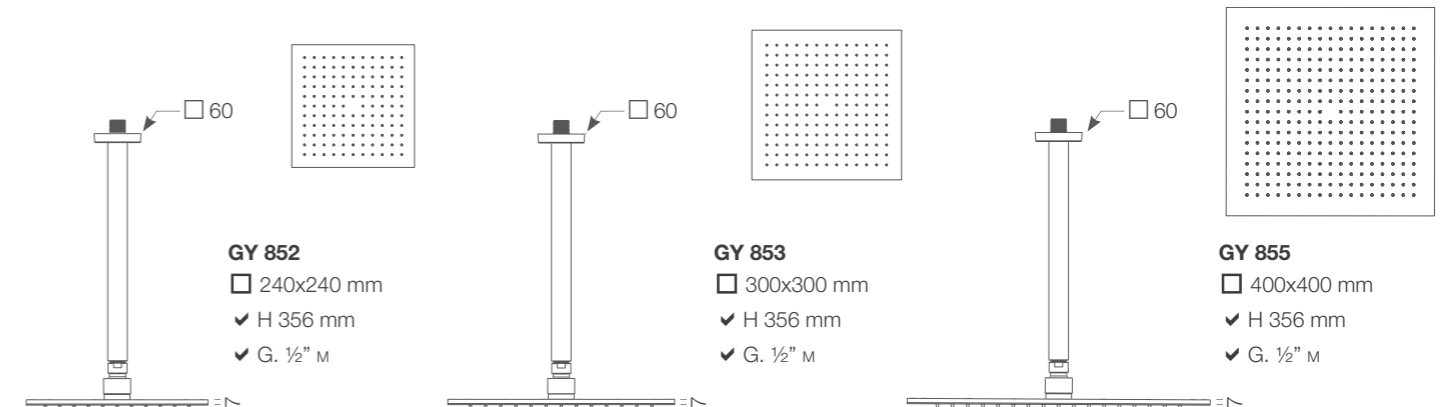

GY 852

□ 240x240 mm  
✓ H 356 mm  
✓ G. 1/2" M

GY 853

□ 300x300 mm  
✓ H 356 mm  
✓ G. 1/2" M

GY 855

□ 400x400 mm  
✓ H 356 mm  
✓ G. 1/2" M



Soffione tondo GIPZY Ø 240 mm.  
✓ GY 002

GIPZY round showerhead Ø 240 mm.

Pomme de douche ronde GIPZY  
Ø 240 mm.



VARIANTI / Variations / Variantes  
■ ORO / BS / RS / ORO-R / NS / NEO  
/ BIO / GG / CR

Soffione tondo GIPZY Ø 300 mm.  
✓ GY 003

GIPZY round showerhead Ø 300 mm.

Pomme de douche ronde GIPZY  
Ø 300 mm.



VARIANTI / Variations / Variantes  
■ ORO / BS / RS / ORO-R / NS / NEO  
/ BIO / GG / CR

Soffione tondo GIPZY Ø 400 mm.  
✓ GY 005

GIPZY round showerhead Ø 400 mm.

Pomme de douche ronde GIPZY  
Ø 400 mm.



VARIANTI / Variations / Variantes  
■ ORO / BS / RS / ORO-R / NS / NEO  
/ BIO / GG / CR



Soffione quadro GIPZY  
240x240 mm.  
✓ GY 402

GIPZY square showerhead  
240x240 mm.

Pomme de douche carrée GIPZY  
240x240 mm.



VARIANTI / Variations / Variantes  
■ ORO / BS / RS / ORO-R / NS / NEO  
/ BIO / GG / CR

Soffione quadro GIPZY  
300x300 mm.  
✓ GY 403

GIPZY square showerhead  
300x300 mm.

Pomme de douche carrée GIPZY  
300x300 mm.



VARIANTI / Variations / Variantes  
■ ORO / BS / RS / ORO-R / NS / NEO  
/ BIO / GG / CR

Soffione quadro GIPZY  
400x400 mm.  
✓ GY 405

GIPZY square showerhead  
400x400 mm.

Pomme de douche carrée GIPZY  
400x400 mm.



VARIANTI / Variations / Variantes  
■ ORO / BS / RS / ORO-R / NS / NEO  
/ BIO / GG / CR

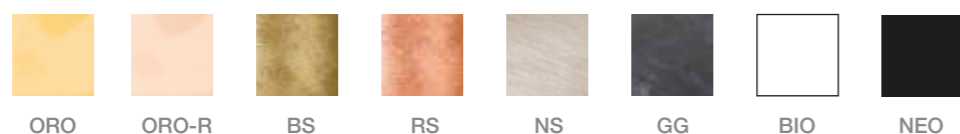

ORO - Oro/Gold/Or ORO-R - Oro rosa/Rose gold/Or rose

BS - Bronzo spazzolato/Brushed brass/Laiton brossé RS - Rame spazzolato/Brushed copper/Cuivre brossé

NS - Nickel spazzolato/Brushed nickel/Nickel brossé GG - Grafite/Graphite CR - Cromo/Chrome

BIO - Bianco opaco/Matte white/Blanche mate NEO - Nero opaco/Matte black/Noire mate

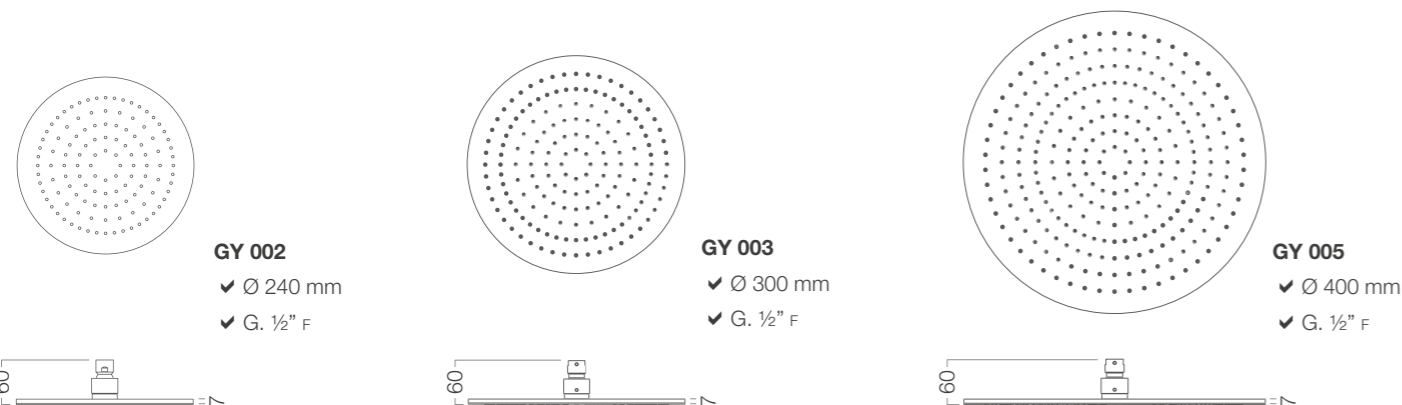

GY 002  
✓ Ø 240 mm  
✓ G. 1/2" F

GY 003  
✓ Ø 300 mm  
✓ G. 1/2" F

GY 005  
✓ Ø 400 mm  
✓ G. 1/2" F

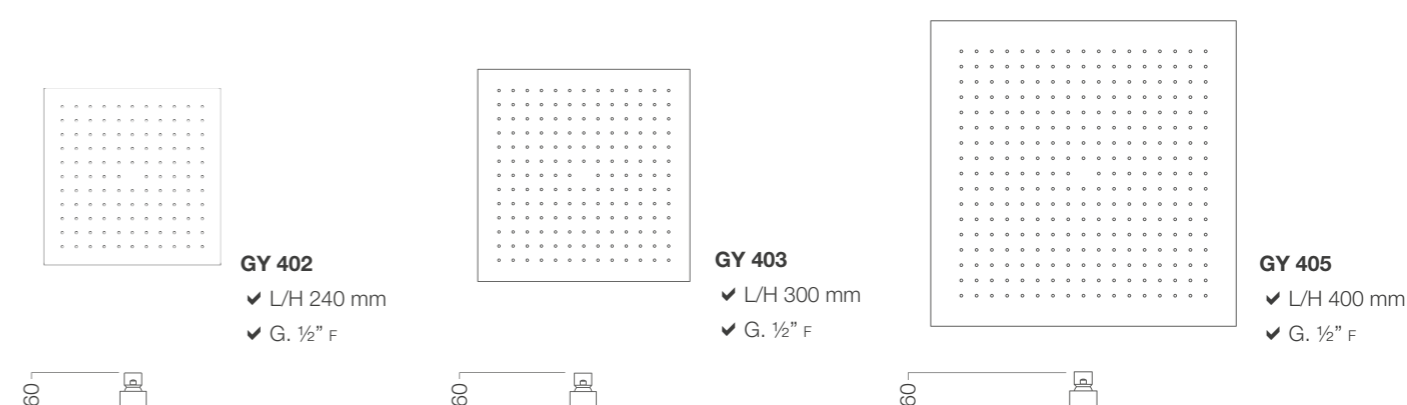

GY 402  
✓ L/H 240 mm  
✓ G. 1/2" F

GY 403  
✓ L/H 300 mm  
✓ G. 1/2" F

GY 405  
✓ L/H 400 mm  
✓ G. 1/2" F

# One Way

La collezione ONE WAY si distingue per le “listarelle”: nuove geometrie per un design originale realizzato con un materiale “parlante”, capace di dare informazioni sulla temperatura dell’acqua.

*The ONE WAY Collection distinguishes itself by its strips, “listerelle”: new geometric shapes for an original design created with a “talking” material, able to give information on the temperature of water.*

*La collection ONE WAY se distingue par les nouvelles géométries de ces “baguettes”: un design innovant créé avec une matière “parlante”, capable de fournir des informations sur la température de l’eau.*





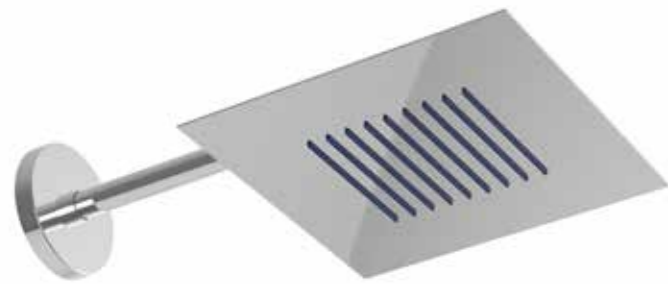

Soffione quadro ONE WAY 300x300 mm,  
braccio doccia tondo 400 mm.

✓ OW 801

ONE WAY square showerhead 300x300 mm,  
round shower arm 400 mm.

Pomme de douche carrée ONE WAY  
300x300 mm, bras mural rond 400 mm.



VARIANTI / Variations / Variantes

■ NE / T

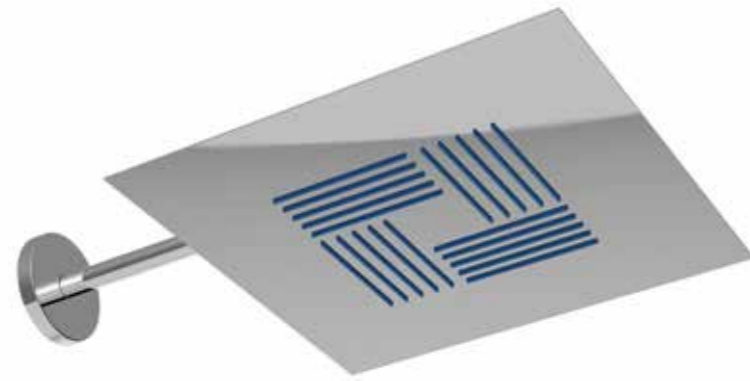

Soffione quadro ONE WAY 470x470 mm,  
braccio doccia tondo 500 mm.

✓ OW 802

ONE WAY square showerhead 470x470 mm,  
round shower arm 500 mm.

Pomme de douche carrée ONE WAY  
470x470 mm, bras mural rond 500 mm.



VARIANTI / Variations / Variantes

■ NE / T



NE - Strisce nere/Black stripes/Baguettes noir

T - Strisce termocromatiche/Thermochromic stripes/Baguettes thermochromique



**OW 801**

- 300x300 mm
- ✓ L 540 mm
- ✓ G. 1/2" M

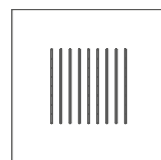

**OW 802**

- 470x470 mm
- ✓ L 712 mm
- ✓ G. 1/2" M

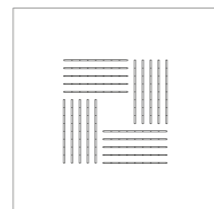

Soffione quadro ONE WAY 300x300 mm.

✓ OW 001

ONE WAY square showerhead 300x300 mm.

Pomme de douche carrée ONE WAY 300x300 mm.



VARIANTI / Variations / Variantes

■ NE / T

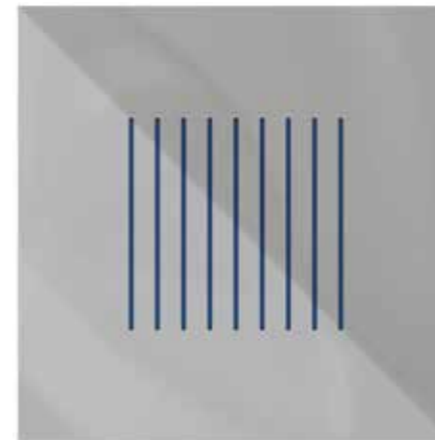

Soffione quadro ONE WAY 470x470 mm.

✓ OW 002

ONE WAY square showerhead 470x470 mm.

Pomme de douche carrée ONE WAY 470x470 mm.



VARIANTI / Variations / Variantes

■ NE / T

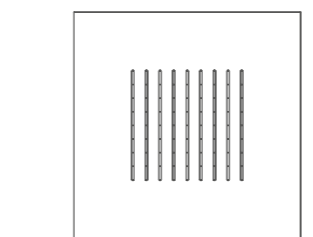

**OW 001**

- ✓ L/H 300 mm
- ✓ G. 1/2" F

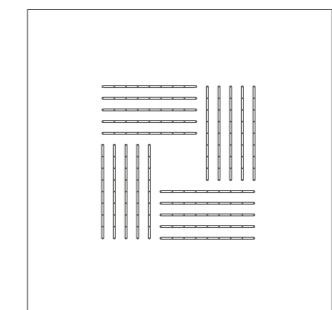

**OW 002**

- ✓ L/H 470 mm
- ✓ G. 1/2" F



Il potere benefico dell'acqua, da sempre fonte di benessere e relax, unito agli effetti positivi della cromoterapia, completa la gamma doccia di Graffio legata al Wellness.

*Water has always been a source of well being and relaxation. Its healthy power, combined with positive effects of Chromotherapy, completes the Graffio range of Wellness showers.*

*Le pouvoir bénéfique de l'eau, source régénérant bien-être et relax, uni aux bienfaits de la chromothérapie, complète la gamme de douches Graffio dédiées au Wellness.*

# Cromoterapia



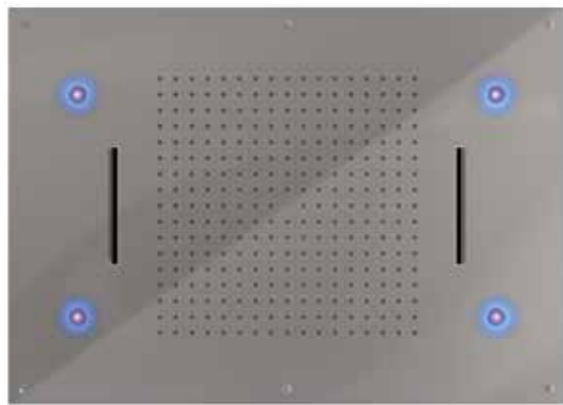

**Soffione rettangolare GIPZY 700x500 mm ad incasso, 2 cascate, cromoterapia con radiocomando.**

✓ GY 271

*GIPZY rectangular ceiling mounted showerhead 700x500 mm, 2 cascades, chromotherapy with remote control.*

*Pomme de douche plafond rectangulaire GIPZY 700x500 mm, encastrée, 2 cascades, chromothérapie avec radiocommande.*



VARIANTI / Variations / Variantes  
■ IX / ORO / NEO / BIO

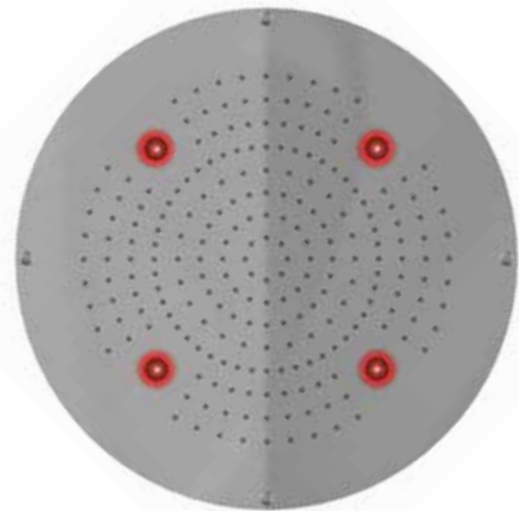

**Soffione tondo GIPZY Ø 470 mm ad incasso, cromoterapia con radiocomando.**

✓ GY 077

*GIPZY round ceiling mounted showerhead Ø 470 mm, chromotherapy with remote control.*

*Pomme de douche plafond ronde GIPZY Ø 470 mm, encastrée, chromothérapie avec radiocommande.*



VARIANTI / Variations / Variantes  
■ IX / ORO / NEO / BIO

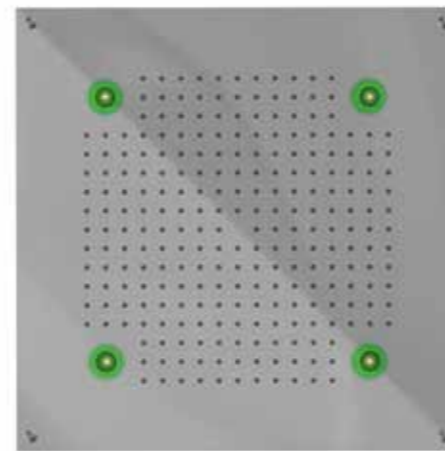

**Soffione quadro GIPZY 470x470 mm ad incasso, cromoterapia con radiocomando.**

✓ GY 477

*GIPZY square ceiling mounted showerhead 470x470 mm, chromotherapy with remote control.*

*Pomme de douche plafond carrée GIPZY 470x470 mm, encastrée, chromothérapie avec radiocommande.*



VARIANTI / Variations / Variantes  
■ IX / ORO / NEO / BIO

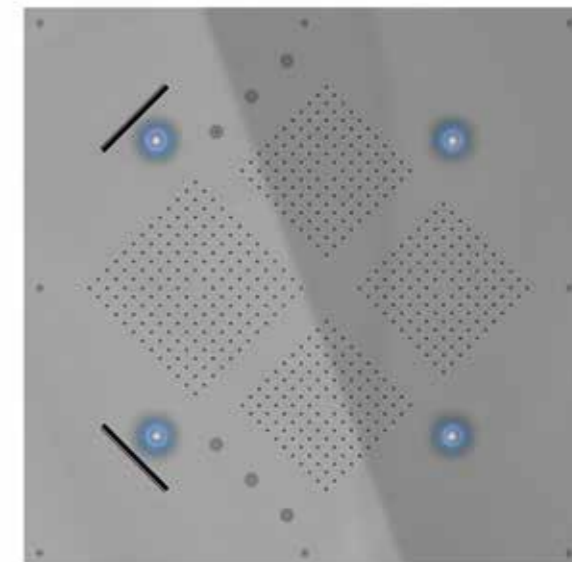

**Soffione quadro KINGS 900x900 mm ad incasso, 2 cascate, 6 nebulizzatori, cromoterapia con radiocomando.**

✓ KI 477

*KINGS square ceiling mounted 900x900 mm showerhead, 2 cascades, 6 mist sprays, chromotherapy with remote control.*

*Pomme de douche plafond carrée KINGS 900x900 mm, encastrée, 2 cascades, 6 jets brumiseurs, chromothérapie avec radiocommande.*



VARIANTI / Variations / Variantes  
■ IX



BIO - Bianco opaco/Matte white/Blanche mate NEO - Nero opaco/Matte black/Noire mate ORO - Oro/Gold/Or IX - Acciaio/Steel/Acier

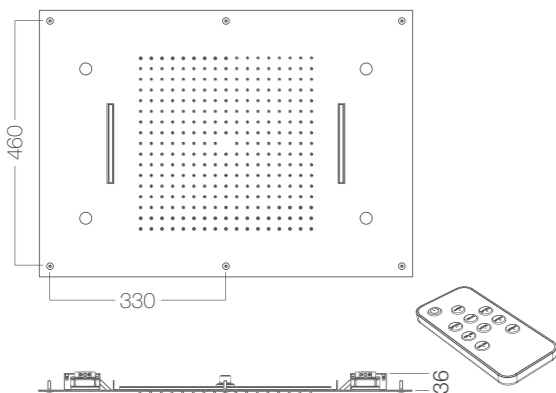

GY 271 ✓ L 700x500 mm ✓ G. 1/2" M

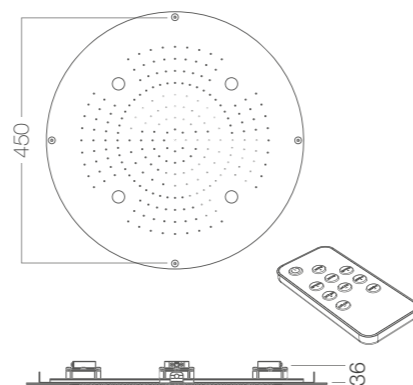

GY 077 ✓ Ø 470 mm ✓ G. 1/2" M

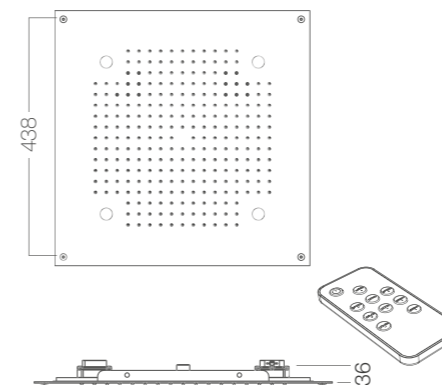

GY 477 ✓ L/H 470 mm ✓ G. 1/2" M

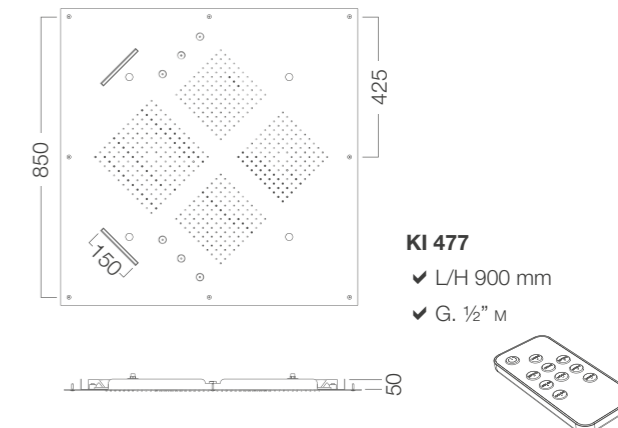

KI 477  
✓ L/H 900 mm  
✓ G. 1/2" M

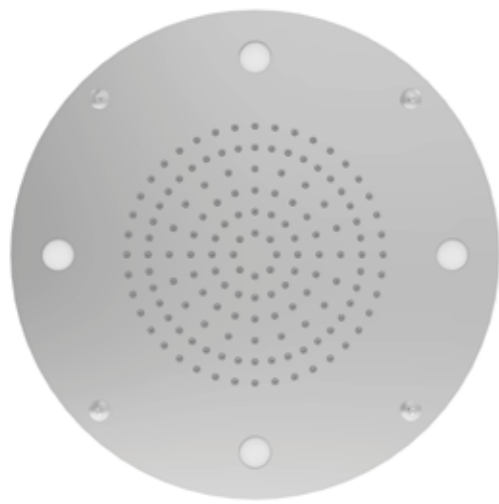

Soffione tondo KINGS Ø 300 mm ad incasso, 4 faretti luce bianca.

✓ KI 270T

KINGS round ceiling mounted showerhead Ø 300 mm, 4 white light LEDs.

Pomme de douche à plafond ronde KINGS Ø 300 mm encastrée, 4 spots feu blanc.



VARIANTI / Variations / Variantes

■ IX

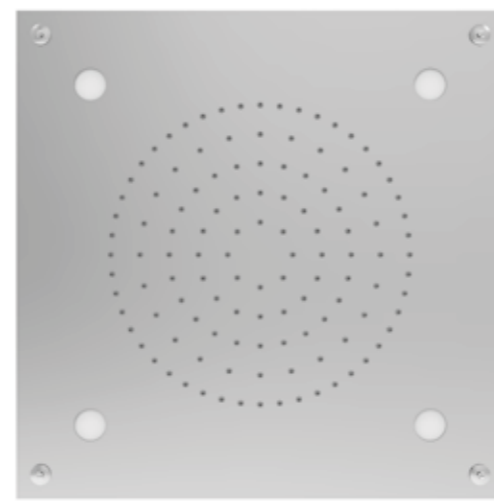

Soffione quadro KINGS 300x300 mm ad incasso, 4 faretti luce bianca.

✓ KI 270Q

KINGS squared ceiling mounted showerhead 300x300 mm, 4 white light LEDs.

Pomme de douche à plafond carrée KINGS 300x300 mm encastrée, 4 spots feu blanc.



VARIANTI / Variations / Variantes

■ IX

Soffione tondo KINGS Ø 300 mm ad incasso, cromoterapia con radiocomando.

✓ KI 570T

KINGS round ceiling mounted showerhead Ø 300 mm, chromotherapy with remote control.

Pomme de douche à plafond ronde KINGS Ø 300 mm encastrée, chromothérapie avec radiocommande.



VARIANTI / Variations / Variantes

■ IX

Soffione quadro KINGS 300x300 mm ad incasso, cromoterapia con radiocomando.

✓ KI 570Q

KINGS squared ceiling mounted showerhead 300x300 mm, chromotherapy with remote control.

Pomme de douche à plafond carrée KINGS 300x300 mm encastrée, chromothérapie avec radiocommande.



VARIANTI / Variations / Variantes

■ IX

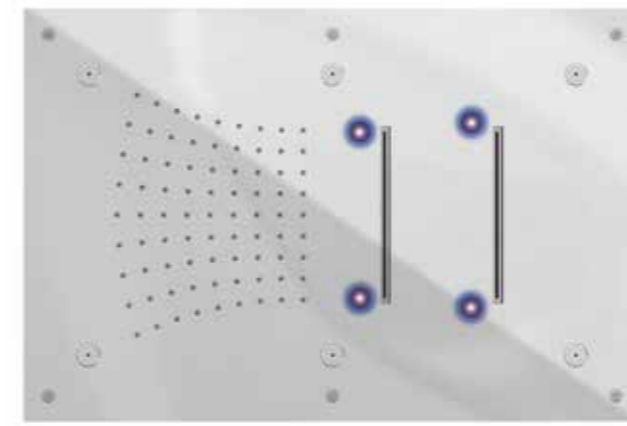

Soffione rettangolare KINGS 600x400 mm ad incasso, 2 cascate, 6 nebulizzatori, cromoterapia con radiocomando.

✓ KI 231

KINGS rectangular ceiling mounted showerhead 600x400 mm, 2 cascades, 6 mist sprays, chromotherapy with remote control.

Pomme de douche plafond rectangulaire KINGS 600x400 mm, encastrée, 2 cascades, 6 jets brumiseurs, chromothérapie avec radiocommande.



VARIANTI / Variations / Variantes

■ IX / ORO / NEO / BIO

Soffione rettangolare ARABESQUE 600x400 mm ad incasso, 2 cascate, 6 nebulizzatori, cromoterapia con radiocomando.

✓ AR 231

ARABESQUE rectangular ceiling mounted showerhead 600x400 mm, 2 cascades, chromotherapy with remote control.

Pomme de douche à plafond rectangulaire ARABESQUE 600x400 mm, encastrée, 2 cascades, chromothérapie avec radiocommande.



VARIANTI / Variations / Variantes

■ ORO / AG / BL / MA / RO / VE

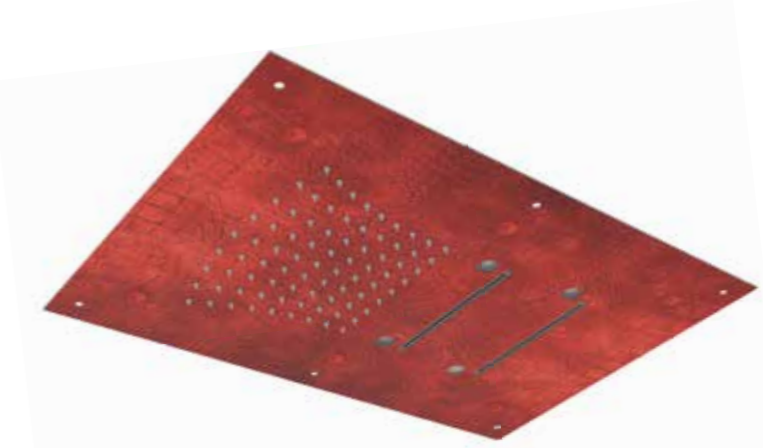

Soffione rettangolare SKIN 600x400 mm ad incasso, 2 cascate, 6 nebulizzatori, cromoterapia con radiocomando.

✓ SK 231

SKIN rectangular ceiling mounted showerhead 600x400 mm, 2 cascades, 6 mist sprays, chromotherapy with remote control.

Pomme de douche plafond rectangulaire SKIN 600x400 mm, encastrée, 2 cascades, 6 jets brumiseurs, chromothérapie avec radiocommande.



VARIANTI / Variations / Variantes

■ ORO / AG / BL / MA / RO / VE

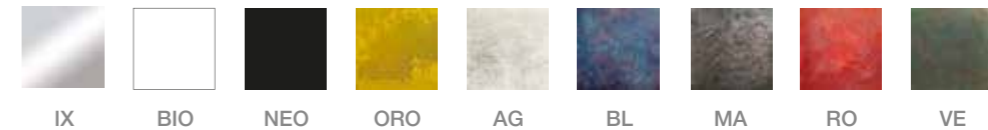

IX - Acciaio/Steel/Acier BIO - Bianco opaco/Matte white/Blanche mate NEO - Nero opaco/Matte black/Noire mate  
 ORO - Oro/Gold/Or AG - Base argento/Silver base/Base argent BL - Base blu/Blue base/Base bleu  
 MA - Base marrone/Brown base/Base brun RO - Base rosso/Red base/Base rouge VE - Base verde/Green base/Base vert

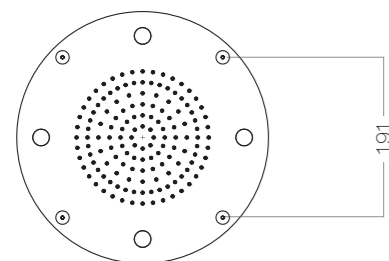

KI 270T / KI 570T

✓ Ø 300 mm  
 ✓ G. 1/2" M

KI 570T / KI 570Q

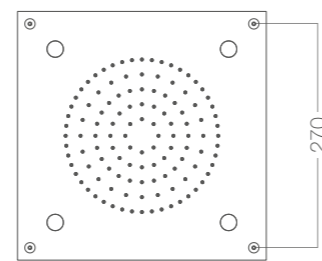

KI 270Q / KI 570Q

✓ L/H 300 mm  
 ✓ G. 1/2" M

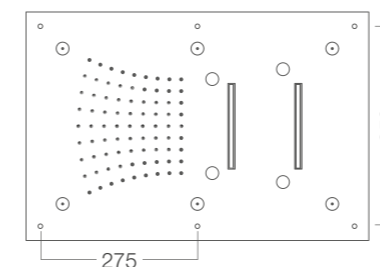

KI 231 / AR 231 / SK 231

✓ L 600x400 mm  
 ✓ G. 1/2" M

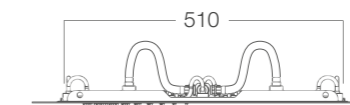

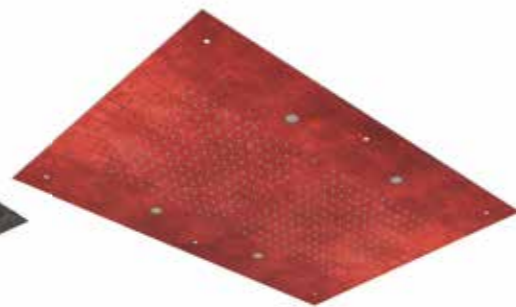
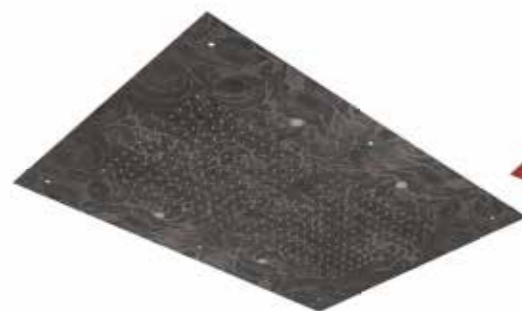
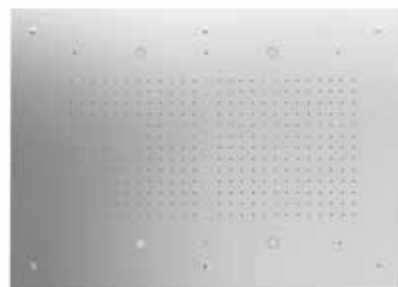

**Soffione rettangolare KINGS**  
700x500 mm ad incasso,  
6 nebulizzatori, cromoterapia  
con radiocomando.

✓ **KI 271**

*KINGS rectangular ceiling mounted  
showerhead 700x500 mm,  
6 mist sprays, chromotherapy  
with remote control.*

*Pomme de douche à plafond  
rectangulaire Kings 700x500 mm  
encastrée, 6 jets brumiseurs,  
chromothérapie avec radiocommande.*



VARIANTI / Variations / Variantes

■ IX / NEO / BIO

**Soffione rettangolare ARABESQUE**  
700x500 mm ad incasso,  
6 nebulizzatori, cromoterapia  
con radiocomando.

✓ **AR 271**

*ARABESQUE rectangular ceiling  
mounted showerhead 700x500 mm,  
6 mist sprays, chromotherapy  
with remote control.*

*Pomme de douche à plafond  
rectangulaire ARABESQUE 700x500  
mm encastrée, 6 jets brumiseurs,  
chromothérapie avec radiocommande.*



VARIANTI / Variations / Variantes

■ ORO / AG / BL / MA / RO / VE

**Soffione rettangolare SKIN**  
700x500 mm ad incasso,  
6 nebulizzatori, cromoterapia  
con radiocomando.

✓ **SK 271**

*SKIN rectangular ceiling mounted  
showerhead 700x500 mm,  
6 mist sprays, chromotherapy  
with remote control.*

*Pomme de douche à plafond  
rectangulaire SKIN 700x500 mm  
encastrée, 6 jets brumiseurs,  
chromothérapie avec radiocommande.*



VARIANTI / Variations / Variantes

■ ORO / AG / BL / MA / RO / VE

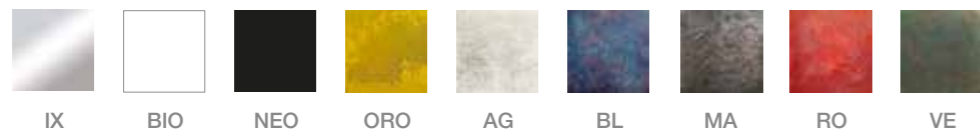

IX - Acciaio/Steel/Acier BIO - Bianco opaco/Matte white/Blanche mate  
NEO - Nero opaco/Matte black/Noire mate  
ORO - Oro/Gold/Or AG - Base argento/Silver base/Base argent BL - Base blu/Blue base/Base bleu  
MA - Base marrone/Brown base/Base brun RO - Base rosso/Red base/Base rouge VE - Base verde/Green base/Base vert

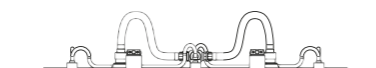
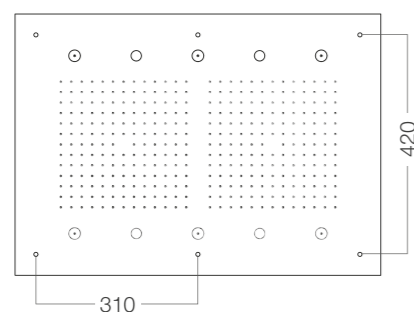

**KI 271 / AR 271 / SK 271**

- ✓ L 700x500 mm
- ✓ G. 1/2" M



La collezione completa di soffioni a soffitto KINGS offre anche versioni multifunzione: soffioni di grandi dimensioni disponibili con rilassanti getti a pioggia, cascate energizzanti e rinfrescanti nebulizzatori. Per portare il Wellness nella propria casa.

*The complete collection of ceiling shower heads KINGS offers also multifunction versions: larger showerheads available with relaxing rainfall jets, energising waterfalls and refreshing nebulizers. To bring wellbeing home.*

*La collection complète de ciels de pluie KINGS offre aussi des versions multifonctions: des ciels de pluie grands formats disponibles avec des jets pluie relaxants, des cascades revitalisantes et des jets nébulisés rafraichissants. Ils permettent d'avoir le Wellness chez soi.*

# Kings

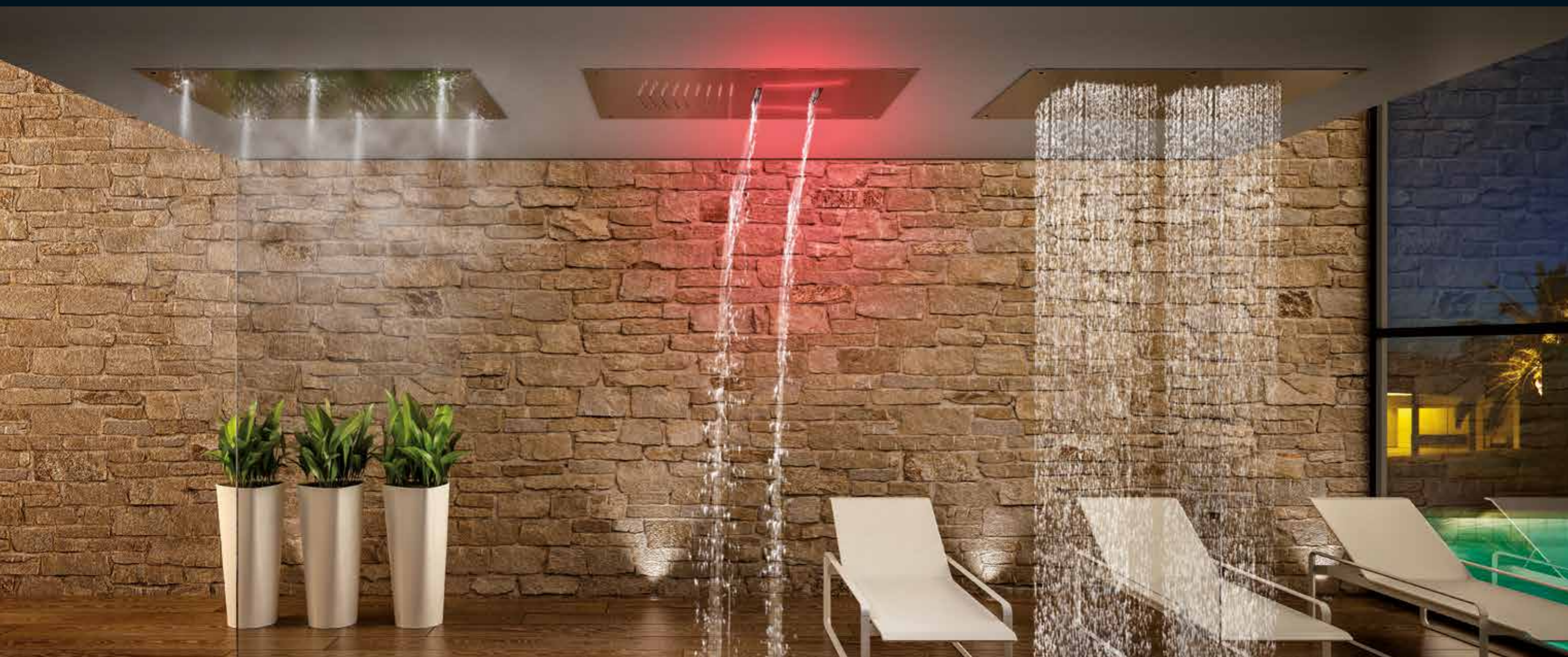

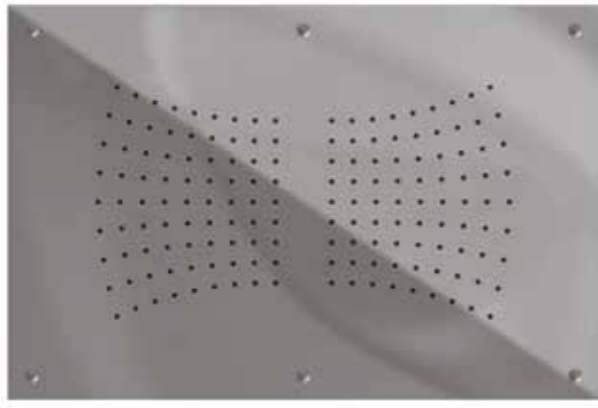

**Soffione rettangolare KINGS 600x400 mm ad incasso.**

✓ KI 201

*KINGS rectangular ceiling mounted showerhead 600x400 mm.*

*Pomme de douche rectangulaire KINGS 600x400 mm, encastrée.*



VARIANTI / Variations / Variantes  
■ IX / ORO / NEO / BIO

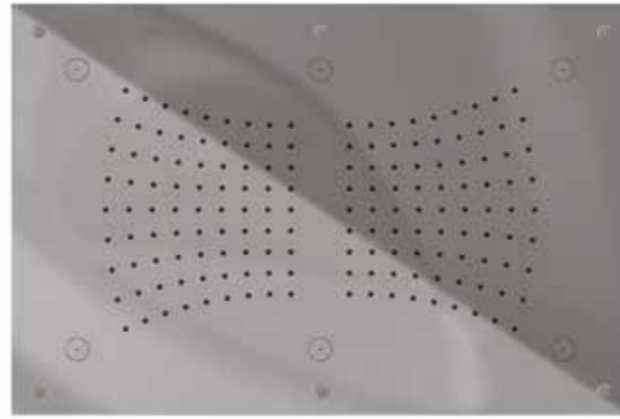

**Soffione rettangolare KINGS 600x400 mm ad incasso, 6 nebulizzatori.**

✓ KI 221

*KINGS rectangular ceiling mounted showerhead 600x400 mm, 6 mist sprays.*

*Pomme de douche rectangulaire KINGS 600x400 mm, encastrée, 6 jets brumiseurs.*



VARIANTI / Variations / Variantes  
■ IX / ORO / NEO / BIO

**Soffione rettangolare KINGS 700x500 mm ad incasso.**

✓ KI 251

*KINGS rectangular ceiling mounted showerhead 700x500 mm.*

*Pomme de douche rectangulaire KINGS 700x500 mm, encastrée.*



VARIANTI / Variations / Variantes  
■ IX / NEO / BIO

**Soffione rettangolare KINGS 700x500 mm ad incasso, 6 nebulizzatori.**

✓ KI 261

*KINGS rectangular ceiling mounted showerhead 700x500 mm, 6 mist sprays.*

*Pomme de douche rectangulaire KINGS 700x500 mm, encastrée, 6 jets brumiseurs.*



VARIANTI / Variations / Variantes  
■ IX / NEO / BIO



**Soffione tondo KINGS Ø 350 mm ad incasso.**

✓ KI 011

*KINGS round ceiling mounted showerhead Ø 350 mm.*

*Pomme de douche ronde KINGS Ø 350 mm, encastrée.*



VARIANTI / Variations / Variantes  
■ IX / ORO / NEO / BIO



**Soffione tondo KINGS Ø 400 mm ad incasso.**

✓ KI 012

*KINGS round ceiling mounted showerhead Ø 400 mm.*

*Pomme de douche ronde KINGS Ø 400 mm, encastrée.*



VARIANTI / Variations / Variantes  
■ IX / ORO / NEO / BIO



**Soffione tondo KINGS Ø 500 mm ad incasso.**

✓ KI 014

*KINGS round ceiling mounted showerhead Ø 500 mm.*

*Pomme de douche ronde KINGS Ø 500 mm, encastrée.*



VARIANTI / Variations / Variantes  
■ IX / ORO / NEO / BIO



BIO - Bianco opaco/Matte white/Blanche mate NEO - Nero opaco/Matte black/Noire mate ORO - Oro/Gold/Or IX - Acciaio/Steel/Acier

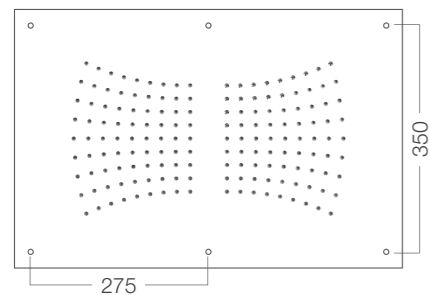

**KI 201**  
✓ L 600x400 mm  
✓ G. 1/2" M

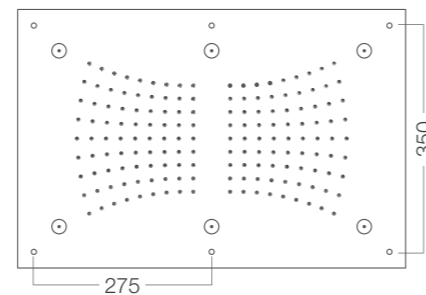

**KI 221 / KI 261**  
✓ L 600x400 mm  
✓ G. 1/2" M

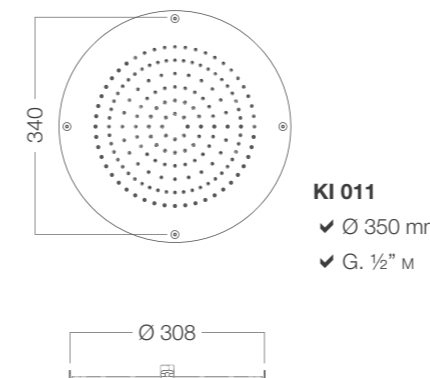

**KI 011**  
✓ Ø 350 mm  
✓ G. 1/2" M

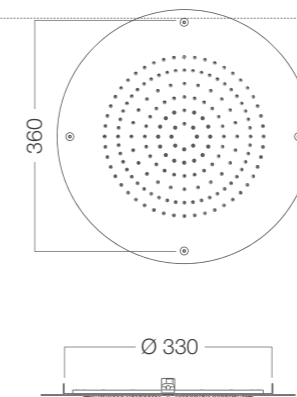

**KI 012**  
✓ Ø 400 mm  
✓ G. 1/2" M

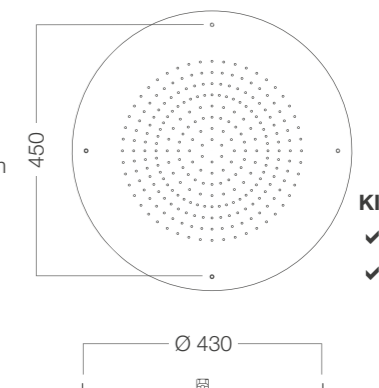

**KI 014**  
✓ Ø 500 mm  
✓ G. 1/2" M

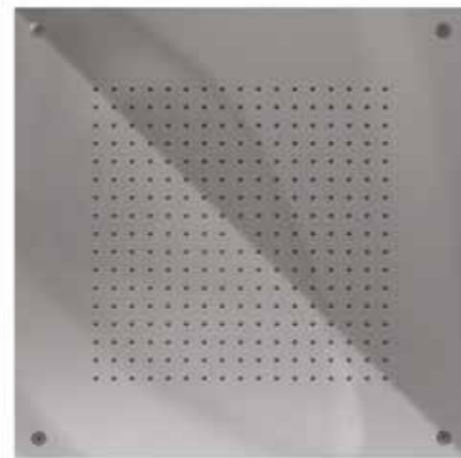
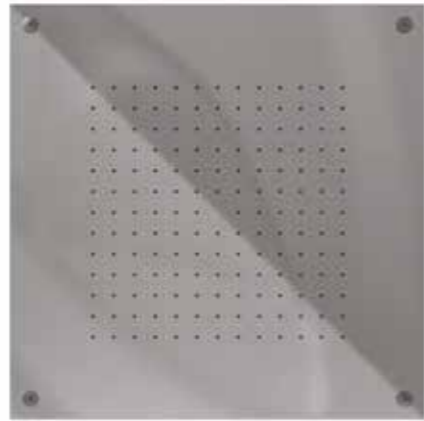
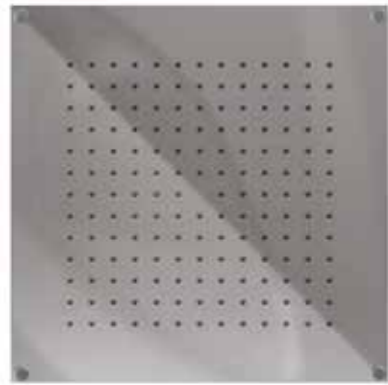

**Soffione quadro KINGS  
350x350 mm ad incasso.**

✓ KI 411

*KINGS square ceiling mounted  
showerhead 350x350 mm.*

*Pomme de douche carrée KINGS  
350x350 mm, encastrée.*



VARIANTI / Variations / Variantes

■ IX / ORO / NEO / BIO

**Soffione quadro KINGS  
400x400 mm ad incasso.**

✓ KI 412

*KINGS square ceiling mounted  
showerhead 400x400 mm.*

*Pomme de douche carrée KINGS  
400x400 mm, encastrée.*



VARIANTI / Variations / Variantes

■ IX / ORO / NEO / BIO

**Soffione quadro KINGS  
500x500 mm ad incasso.**

✓ KI 414

*KINGS square ceiling mounted  
showerhead 500x500 mm.*

*Pomme de douche carrée KINGS  
500x500 mm, encastrée.*



VARIANTI / Variations / Variantes

■ IX / ORO / NEO / BIO

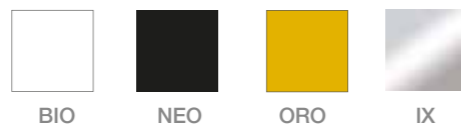

BIO - Bianco opaco/Matte white/Blanche mate NEO - Nero opaco/Matte black/Noire mate ORO - Oro/Gold/Or IX - Acciaio/Steel/Acier

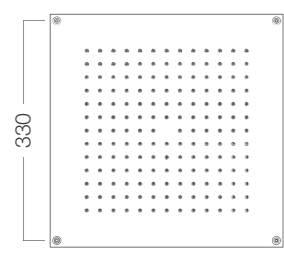

**KI 411**

- ✓ L/H 350 mm
- ✓ G. 1/2" M

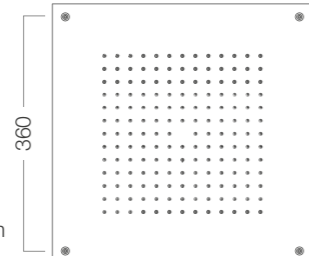

**KI 412**

- ✓ L/H 400 mm
- ✓ G. 1/2" M

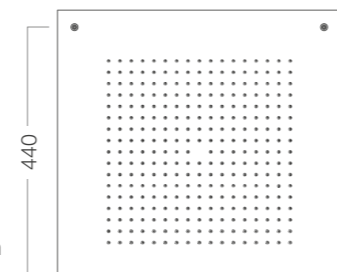

**KI 414**

- ✓ L/H 500 mm
- ✓ G. 1/2" M





L'eleganza dell'essenzialità. Rettangolare o arrotondata è la soluzione ideale per rinnovare il bagno senza interventi di demolizione. Studiato appositamente per essere utilizzato anche sulle pareti in cartongesso grazie al particolare attacco.

*Elegance of the basic. Rectangular or rounded it's the perfect solution to renew bathroom without demolition. Its fixing system is specifically studied to be used on plasterboard walls too.*

*L'élégance de l'essentialité. Rectangulaire ou arrondi c'est la meilleure solution pour rénover la salle de bain sans démolir. Étudié spécialement pour être utilisé sur les mur en placoplâtre par son particulier system de fixation.*

# Street

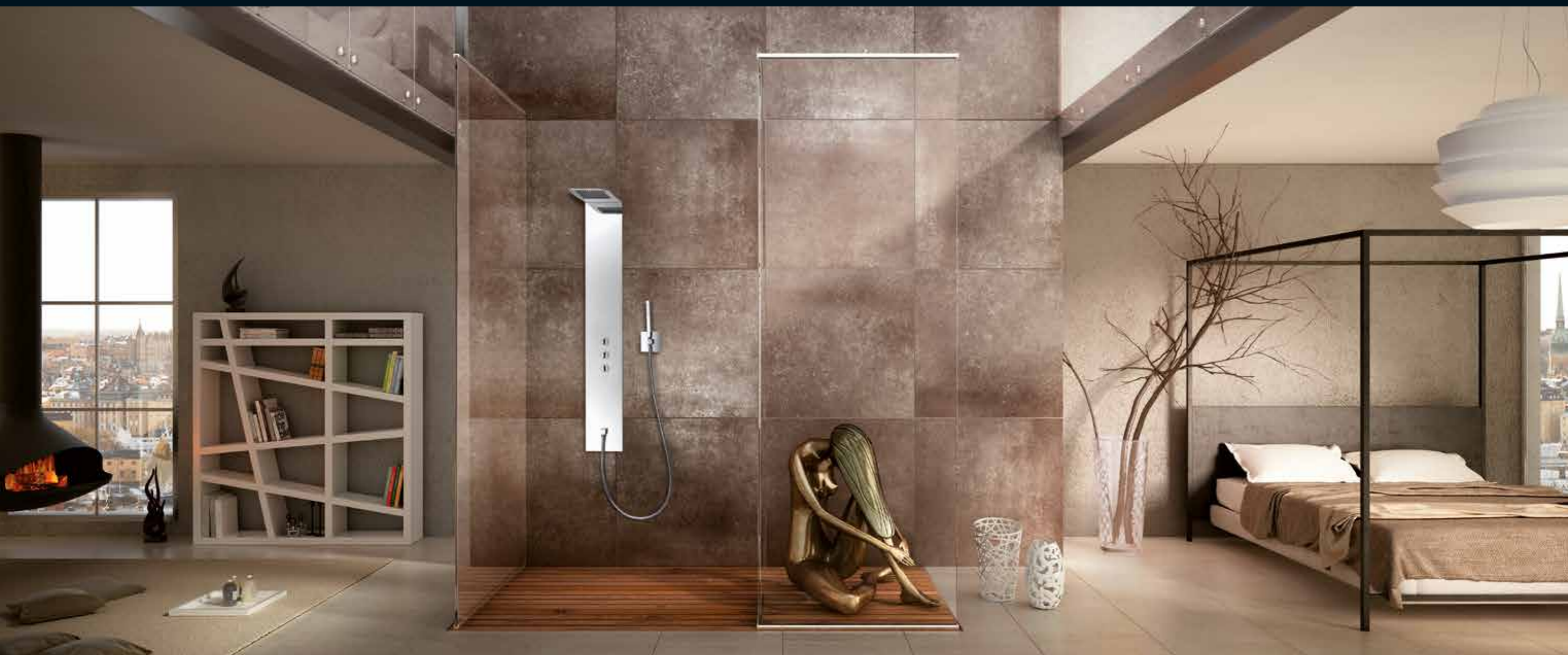



Soffione arrotondato STREET  
300x120 mm, inclinato,  
attacco a parete.

✓ ST 201

STREET wall mounted rounded  
inclined showerhead 300x120 mm.

Pomme de douche murale arrondie  
STREET, incliné, 300x120 mm.



VARIANTI / Variations / Variantes  
■ IX

Soffione arrotondato STREET  
420x170 mm, attacco a parete.

✓ ST 202

STREET wall mounted rounded  
showerhead 420x170 mm.

Pomme de douche murale arrondie  
STREET 420x170 mm.



VARIANTI / Variations / Variantes  
■ IX

Soffione arrotondato STREET  
530x220 mm, attacco a parete.

✓ ST 203

STREET wall mounted rounded  
showerhead 530x220 mm.

Pomme de douche murale  
arrondie STREET 530x220 mm.



VARIANTI / Variations / Variantes  
■ IX



IX

IX - Acciaio/Steel/Acier

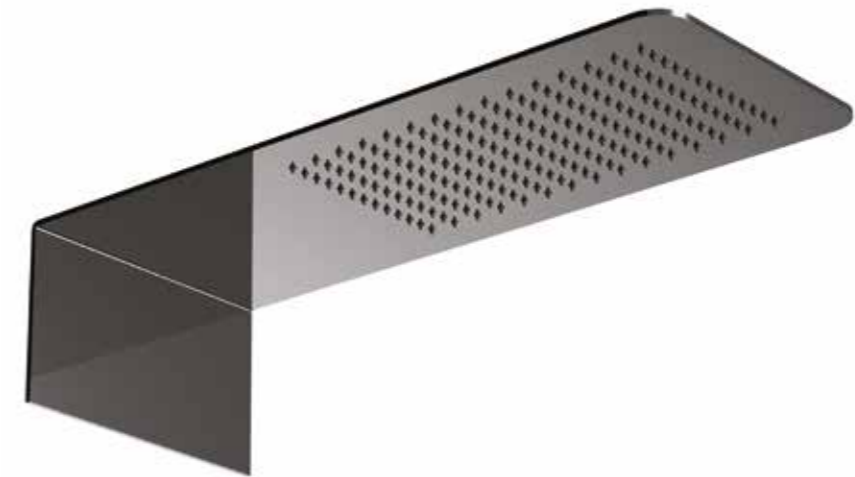

Soffione rettangolare STREET  
300x120 mm, angoli raggiati,  
inclinato, attacco a parete.

✓ ST 001

STREET rectangular inclined smooth  
angles wall mounted showerhead  
300x120 mm.

Pomme de douche murale  
rectangulaire STREET, incliné  
300x120 mm, angles arrondis.



VARIANTI / Variations / Variantes  
■ IX

Soffione rettangolare STREET  
420x170 mm, angoli raggiati,  
attacco a parete.

✓ ST 002

STREET rectangular smooth angles  
wall mounted showerhead  
420x170 mm.

Pomme de douche murale  
rectangulaire STREET 420x170 mm,  
angles arrondis.



VARIANTI / Variations / Variantes  
■ IX

Soffione rettangolare STREET  
530x220 mm, angoli raggiati,  
attacco a parete.

✓ ST 003

STREET rectangular smooth angles  
wall mounted showerhead  
530x220 mm.

Pomme de douche murale  
rectangulaire STREET 530x220 mm,  
angles arrondis.



VARIANTI / Variations / Variantes  
■ IX

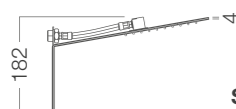

ST 201

- ✓ L 300x120 mm
- ✓ G. 1/2" M

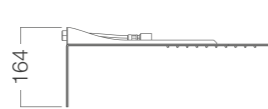

ST 202

- ✓ L 420x170 mm
- ✓ G. 1/2" M

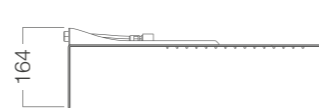

ST 203

- ✓ L 530x220 mm
- ✓ G. 1/2" M

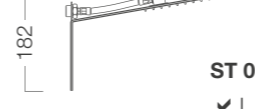

ST 001

- ✓ L 300x120 mm
- ✓ G. 1/2" M

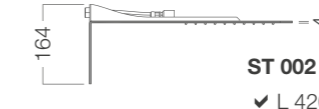
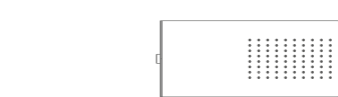

ST 002

- ✓ L 420x170 mm
- ✓ G. 1/2" M

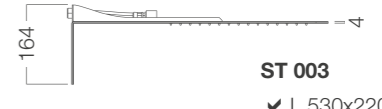
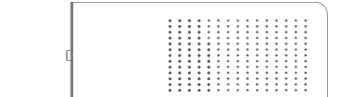

ST 003

- ✓ L 530x220 mm
- ✓ G. 1/2" M

Una doccia in cristallo e acciaio sospesa nel vuoto, semplice e affascinante protagonista in ogni sala da bagno. Indicata per riposizionare il punto doccia nella stanza senza interventi strutturali invasivi e costosi.

*A hanging in the air crystal and stainless steel shower, simple and charming it's the protagonist in every bathroom. Indicated to rearrange shower position avoiding invasive and expensive structural interventions.*

*Une douche en cristal et acier inox suspendu dans le vide, simple et fascinante protagoniste de chaque salle de bain. Indiquée pour la ré-collocation du point douche en évitant modifications à la structure envahissantes et coûteuses.*

# Crystal



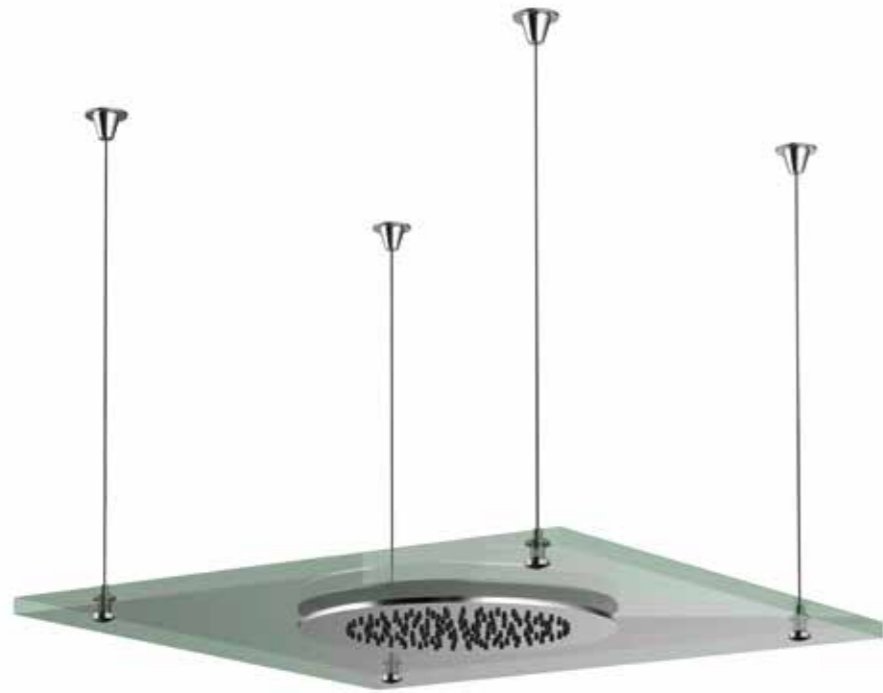

Soffione quadro CRYSTAL 450x450 mm, attacchi a soffitto.

✓ CR 001

CRYSTAL square ceiling mounted showerhead 450x450 mm.

Pomme de douche carrée CRYSTAL 450x450 mm, plafond.



VARIANTI VETRO / Glass variations / Variantes verre

■ T / BI / NE



Soffione rettangolare doppio CRYSTAL, 900x450 mm, attacchi a soffitto.

✓ CR 002

CRYSTAL rectangular ceiling mounted double showerhead 900x450 mm.

Pomme de douche rectangulaire CRYSTAL 900x450 mm, plafond, 2 pommes de douche.



VARIANTI VETRO / Glass variations / Variantes verre

■ T / BI / NE



BI - Bianco/White/Blanc NE - Nero/Black/Noir T - Trasparente/Transparent

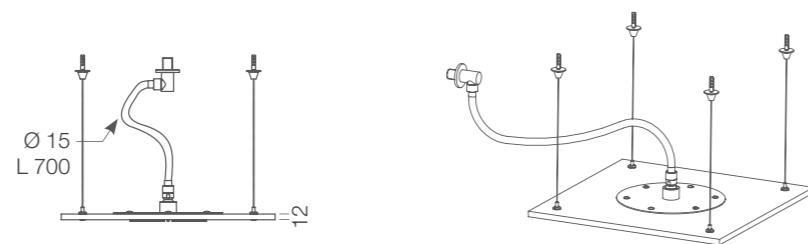
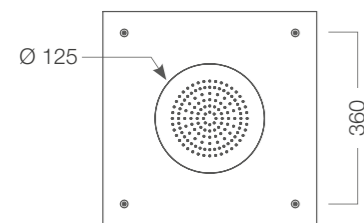

**CR 001**  
 □ 450x450 mm  
 ✓ G. 1/2" M

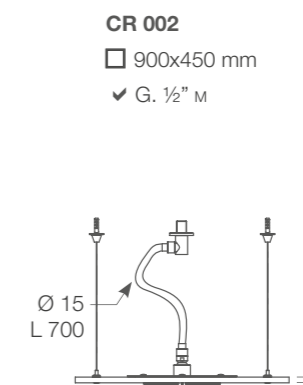
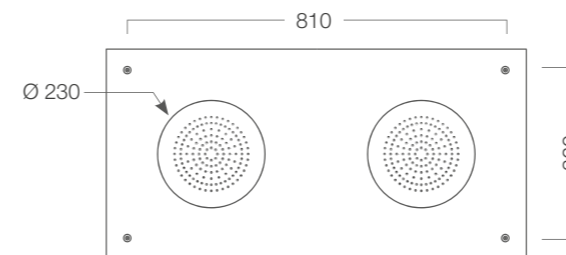

**CR 002**  
 □ 900x450 mm  
 ✓ G. 1/2" M

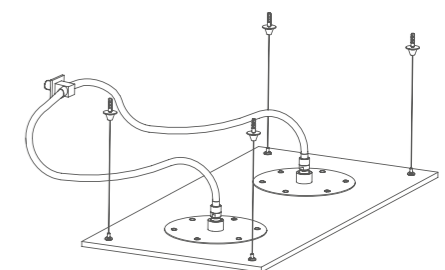

L'eco-sostenibilità va vissuta. Il design è progettazione industriale alla base del quale sta la ricerca. L'alluminio è una lega priva di sostanze tossiche e totalmente riciclabile. Nuova Osmo è l'unica azienda a portare avanti la ricerca sui soffioni in alluminio. La collezione ALLUMINIO favorisce il risparmio idrico ed energetico e la facilità di installazione.

*Environmental sustainability should be lived. Design is the industrial project which is supported by research. Aluminium is a metal containing no toxic substance and totally recyclable. Nuova Osmo is the only company to move forward in the research of aluminium showerheads. The ALLUMINIO collection not only favours energy and hydro saving but also ease of installation.*

*Vivre dans le respect de l'environnement. Le design est dans le projet industriel qui se base sur la recherche. L'aluminium est un alliage dépourvu de substances toxique et complètement recyclable. Nuova Osmo est la seule entreprise qui a entrepris la recherche sur les pommes de douches en aluminium. La collection ALLUMINIO favorise les économies hydriques et énergétiques et facilite l'installation.*

# Alluminio





Soffione quadro TEKNO.AL  
200x200 mm, braccio doccia  
quadro 350 mm.

✓ TA 841

TEKNO.AL square showerhead  
200x200 mm, square shower arm  
350 mm.

Pomme de douche carrée TEKNO.  
200x200 mm, bras mural carré  
350 mm.



VARIANTI / Variations / Variantes

■ ANB / ANR / ANN / ANBL / ANV / ANG



Soffione quadro TEKNO.AL  
200x200 mm, braccio doccia  
quadro 300 mm, attacco a soffitto.

✓ TA 851

TEKNO.AL square showerhead  
200x200 mm, square ceiling mounted  
shower arm 300 mm.

Pomme de douche carrée TEKNO.AL  
200x200 mm, bras plafond carré  
300 mm.



VARIANTI / Variations / Variantes

■ ANB / ANR / ANN / ANBL / ANV / ANG

Soffione quadro TEKNO.AL  
200x200 mm.

✓ TA 401

TEKNO.AL square showerhead  
200x200 mm.

Pomme de douche carrée TEKNO.AL  
200x200 mm.



VARIANTI / Variations / Variantes

■ ANB / ANR / ANN / ANBL / ANV / ANG



Soffione quadro TEKNO.AL  
240x240 mm, braccio doccia  
quadro 350 mm.

✓ TA 842

TEKNO.AL square showerhead  
240x240 mm, square shower arm  
350 mm.

Pomme de douche carrée TEKNO.AL  
240x240 mm, bras mural carré  
350 mm.



VARIANTI / Variations / Variantes

■ ANB / ANR / ANN / ANBL / ANV / ANG



Soffione quadro TEKNO.AL  
240x240 mm, braccio doccia  
quadro 300 mm, attacco a soffitto.

✓ TA 852

TEKNO.AL square showerhead  
240x240 mm, square ceiling mounted  
shower arm 300 mm.

Pomme de douche carrée TEKNO.AL  
240x240 mm, bras plafond carré  
300 mm.



VARIANTI / Variations / Variantes

■ ANB / ANR / ANN / ANBL / ANV / ANG

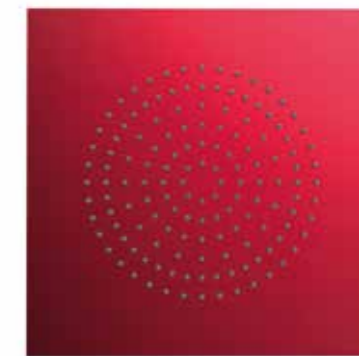

Soffione quadro TEKNO.AL  
240x240 mm.

✓ TA 402

TEKNO.AL square showerhead  
240x240 mm.

Pomme de douche carrée TEKNO.AL  
240x240 mm.



VARIANTI / Variations / Variantes

■ ANB / ANR / ANN / ANBL / ANV / ANG



ANB - Anodizzato brillante/Anodized glittering/Anodisé brillant ANR - Anodizzato rosso/Anodized red/Anodisé rouge  
ANN - Anodizzato nero/Anodized black/Anodisé noir ANBL - Anodizzato blu/Anodized blue/Anodisé bleu  
ANV - Anodizzato verde/Anodized green/Anodisé vert ANG - Anodizzato oro/Anodized gold/Anodisé or



TA 841

□ 200x200 mm  
✓ L 450 mm  
✓ G. 1/2" M

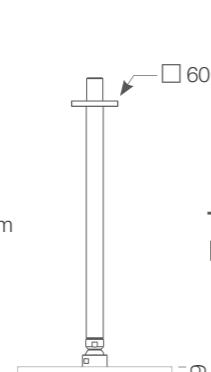

TA 851

□ 200x200 mm  
✓ H 354 mm  
✓ G. 1/2" M

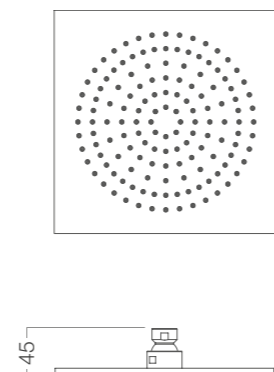

TA 401

✓ L/H 200 mm  
✓ G. 1/2" F



TA 842

□ 240x240 mm  
✓ L 470 mm  
✓ G. 1/2" M

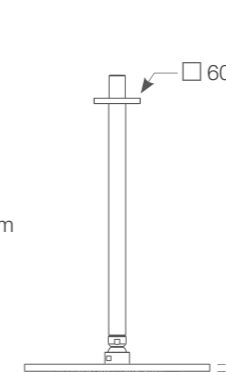

TA 852

□ 240x240 mm  
✓ H 354 mm  
✓ G. 1/2" M

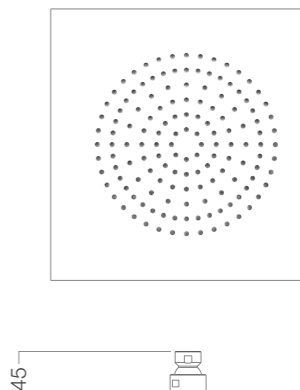

TA 402

✓ L/H 240 mm  
✓ G. 1/2" F



Soffione tondo TEKNO.AL  
Ø 200 mm, braccio doccia tondo  
350 mm.

✓ TA 801

TEKNO.AL round showerhead Ø 200  
mm, round shower arm 350 mm.

Pomme de douche ronde TEKNO.AL  
Ø 200 mm, bras mural rond 350 mm.



VARIANTI / Variations / Variantes

■ ANB / ANR / ANN / ANBL / ANV / ANG



Soffione tondo TEKNO.AL  
Ø 200 mm, braccio doccia tondo  
300 mm, attacco a soffitto.

✓ TA 811

TEKNO.AL round showerhead Ø 200  
mm, round ceiling mounted shower  
arm 300 mm.

Pomme de douche ronde TEKNO.AL  
Ø 200 mm, bras plafond rond  
300 mm.



VARIANTI / Variations / Variantes

■ ANB / ANR / ANN / ANBL / ANV / ANG

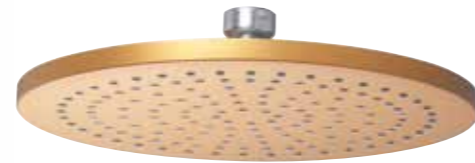

Soffione tondo TEKNO.AL  
Ø 200 mm.

✓ TA 001

TEKNO.AL round showerhead  
Ø 200 mm.

Pomme de douche ronde TEKNO.AL  
Ø 200 mm.



VARIANTI / Variations / Variantes

■ ANB / ANR / ANN / ANBL / ANV / ANG



Soffione tondo TEKNO.AL  
Ø 240 mm, braccio doccia tondo  
350 mm.

✓ TA 802

TEKNO.AL round showerhead  
Ø 240 mm, round shower arm  
350 mm.

Pomme de douche ronde TEKNO.AL  
Ø 240 mm, bras mural rond 350 mm.



VARIANTI / Variations / Variantes

■ ANB / ANR / ANN / ANBL / ANV / ANG



Soffione tondo TEKNO.AL  
Ø 240 mm, braccio doccia tondo  
300 mm, attacco a soffitto.

✓ TA 812

TEKNO.AL round showerhead  
Ø 240 mm, round ceiling mounted  
shower arm 300 mm.

Pomme de douche ronde TEKNO.AL  
Ø 240 mm, bras plafond rond  
300 mm.



VARIANTI / Variations / Variantes

■ ANB / ANR / ANN / ANBL / ANV / ANG

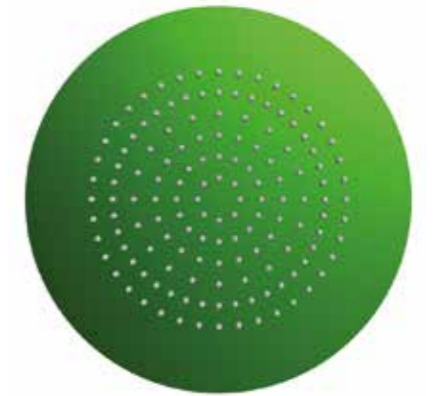

Soffione tondo TEKNO.AL  
Ø 240 mm.

✓ TA 002

TEKNO.AL round showerhead  
Ø 240 mm.

Pomme de douche ronde TEKNO.AL  
Ø 240 mm.



VARIANTI / Variations / Variantes

■ ANB / ANR / ANN / ANBL / ANV / ANG



ANB - Anodizzato brillante/Anodized glittering/Anodisé brillant ANR - Anodizzato rosso/Anodized red/Anodisé rouge  
ANN - Anodizzato nero/Anodized black/Anodisé noir ANBL - Anodizzato blu/Anodized blue/Anodisé bleu  
ANV - Anodizzato verde/Anodized green/Anodisé vert ANG - Anodizzato oro/Anodized gold/Anodisé or

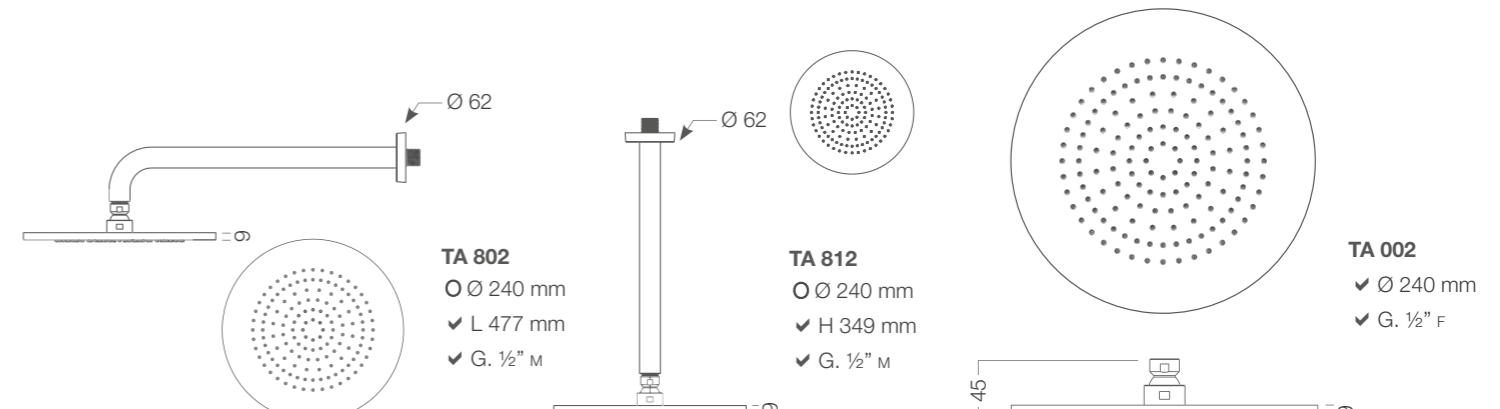
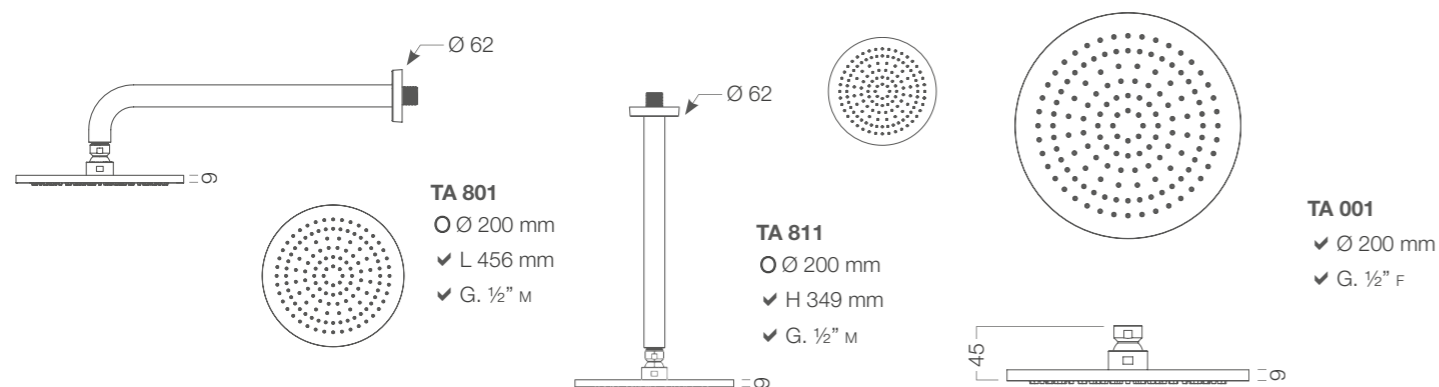

Le geometrie semplici rendono Galileo unico ed elegante come elemento d'arredo e le sue funzionalità, capaci di regalare un getto importante ma con utilizzo ridotto di acqua, introducono a una nuova dimensione del piacere di fare la doccia.

*The simple geometry makes Galileo a unique and elegant home feature. Loose yourself into a new pleasure dimension in having shower thanks to its functionality, able to save water maintaining a strong rain spray.*

*Avec ses simples géométries Galileo se traduit dans un objet d'ornement unique. De la même façon ses fonctionnalités introduisent dans une nouvelle dimension de plaisir de faire la douche, en offrent un bon jet et bien une réduite consommation d'eau.*



Soffione quadro GALILEO 400x400 mm  
attacco a soffitto.

✓ GA 001

*GALILEO square ceiling mounted showerhead  
400x400 mm.*

*Pomme de douche plafond carrée GALILEO  
400x400 mm.*



VARIANTI / Variations / Variantes

■ ANB / ANN



ANB

ANN

ANB - Anodizzato brillante/Anodized glittering/Anodisé brillant  
ANN - Anodizzato nero/Anodized black/Anodisé noir

GA 001

□ 400x400 mm

✓ H 345 mm

✓ G. 1/2" M

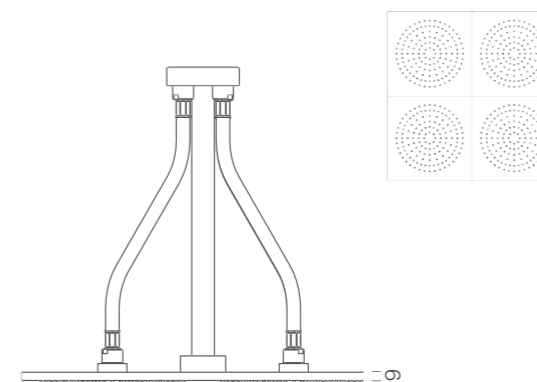



Soffione DARWIN 200x410 mm,  
 attacco a parete, getto pioggia e cascata.

✓ DW 001

*DARWIN wall mounted showerhead  
 200x410 mm, rain and cascade jet.*

*Pomme de douche murale DARWIN  
 200x410 mm, jet à pluie et cascade.*



VARIANTI / Variations / Variantes

■ ANB / ANN



ANB ANN

ANB - Anodizzato brillante/Anodized glittering/Anodisé brillant  
 ANN - Anodizzato nero/Anodized black/Anodisé noir



design Luca Papini

DW 001

✓ L 200x410 mm

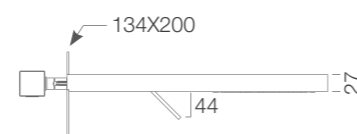
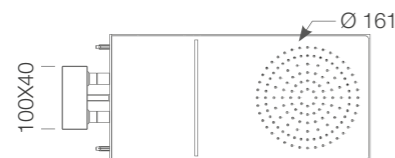

Il corretto e proficuo utilizzo dell'acqua è sempre alla base del lavoro dei nostri tecnici. Quando nel 2008 insieme al designer Luca Papini è stato studiato il soffione Darwin, tutti i particolari sono stati pensati per ottenere un confortevole getto pioggia ed un notevole getto cascata pur mantenendo basse le portate. Il prodotto nel 2010 è stato premiato al Good Design Awards di Chicago nella sezione Bath & Accessories.

*The correct and profitable use of water is always the base of the work of our technicians. When in 2008, together with the designer Luca Papini, the Darwin showerhead was studied, all the details have been designed to obtain a comfortable rain jet and a considerable waterfall jet while keeping the flow rates low. The product was awarded in 2010 at the Good Design of Chicago in the Bath & Accessories section.*

*L'usage correct et avantageux de l'eau est toujours la base de travail de notre personnel technique. Dans l'année 2008 quand, avec le designer Luca Papini, la pomme de douche Darwin a été étudiée, tous les détails ont été réalisés à obtenir une pluie confortable et une remarquable cascade, et dans le même temps en gardant à une débit contenu. Le produit a été primé dans le 2010 au Good Design Awards de Chicago dans la section Bath & Accessories.*





Soffione NEWTON 240x470 mm, attacco a parete.

✓ NW 001

NEWTON wall mounted showerhead 240x470 mm.

Pomme de douche murale NEWTON 240x470 mm.



VARIANTI / Variations / Variantes

■ ANB / ANN

Soffione KUBRICK 200x450 mm, attacco a parete.

✓ KU 001

KUBRICK wall mounted showerhead 200x450 mm.

Pomme de douche murale KUBRICK 200x450 mm.



VARIANTI / Variations / Variantes

■ ANB / ANN



Soffione raggiato GIOTTO 240x472 mm, attacco a parete.

✓ GI 001

GIOTTO rounded wall mounted showerhead 240x472 mm.

Pomme de douche murale arrondie GIOTTO 240x472 mm.



VARIANTI / Variations / Variantes

■ ANB / ANN

Soffione rettangolare QUARK 240x472 mm, attacco a parete.

✓ QU 201

QUARK rectangular wall mounted showerhead 240x472 mm.

Pomme de douche murale rectangulaire QUARK 240x472 mm.



VARIANTI / Variations / Variantes

■ ANB / ANN



ANB

ANN

ANB - Anodizzato brillante/Anodized glittering/Anodisé brillant  
ANN - Anodizzato nero/Anodized black/Anodisé noir

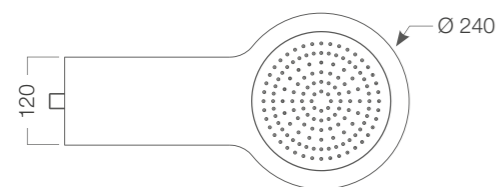

NW 001

✓ L 470 mm  
✓ G. 1/2" M

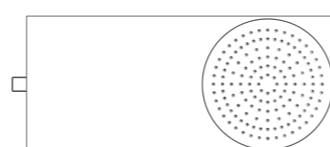

KU 001

✓ L 200x450 mm  
✓ G. 1/2" M

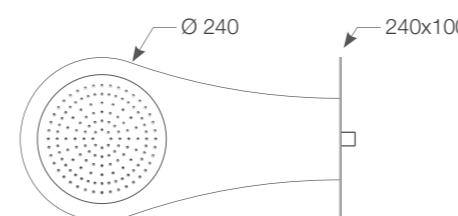

GI 001

✓ L 472 mm  
✓ G. 1/2" M

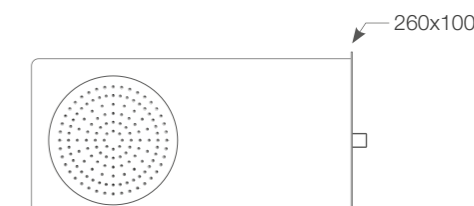

QU 201

✓ L 240x472 mm  
✓ G. 1/2" M

La linea Graffio offre soluzioni bagno complete. Una "haute couture" di lusso per l'ambiente doccia.

*The Graffio line offers complete bathroom solutions. A luxury "haute couture" for the shower environment.*

*La ligne Graffio offre des solutions complètes, une haute couture de luxe pour l'espace douche.*

# Ambienti





**Ambiente completo tondo.**

Braccio, soffione, miscelatore incasso.

✓ AM 010 M

*Complete round shower setting.*

*Wall arm, shower head, concealed mixer.*

*Ambiance complète ronde.*

*Bras mural, pomme de douche, mitigeur à encastrer.*



VARIANTI / Variations / Variantes

■ CR

**Ambiente completo quadro.**

Braccio, soffione, miscelatore incasso.

✓ AM 410 M

*Complete squared shower setting.*

*Wall arm, shower head, concealed mixer.*

*Ambiance complète carrée.*

*Bras mural, pomme de douche, mitigeur à encastrer.*



VARIANTI / Variations / Variantes

■ CR

**AM 010 / AM 410**

Ø 400 mm

□ 400x400 mm

✓ H 210 mm

✓ G. ½" M

QUOTE CONSIGLIATE/  
Recommended distances/  
Distances recommandées

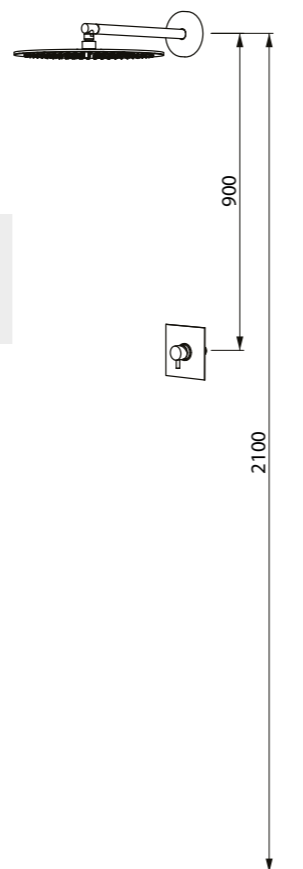

**Ambiente completo tondo.**

Braccio, soffione, miscelatore incasso, presa acqua c/supp, doccia e flex.

✓ AM 020 M

*Complete round shower setting.*

*Wall arm, shower head, concealed mixer, water outlet with support, handshower and flexible hose.*

*Ambiance complète ronde.*

*Bras mural, pomme de douche, mitigeur à encastrer, prise d'eau avec support, douchette et flexible.*



VARIANTI / Variations / Variantes

■ CR

**Ambiente completo quadro.**

Braccio, soffione, miscelatore incasso, presa acqua c/supp, doccia e flex.

✓ AM 420 M

*Complete squared shower setting.*

*Wall arm, shower head, concealed mixer, water outlet with support, handshower and flexible hose.*

*Ambiance complète carrée.*

*Bras mural, pomme de douche, mitigeur à encastrer, prise d'eau avec support, douchette et flexible.*



VARIANTI / Variations / Variantes

■ CR

**AM 020 / AM 420**

Ø 400 mm

□ 400x400 mm

✓ H 210 mm

✓ G. ½" M

QUOTE CONSIGLIATE/  
Recommended distances/  
Distances recommandées

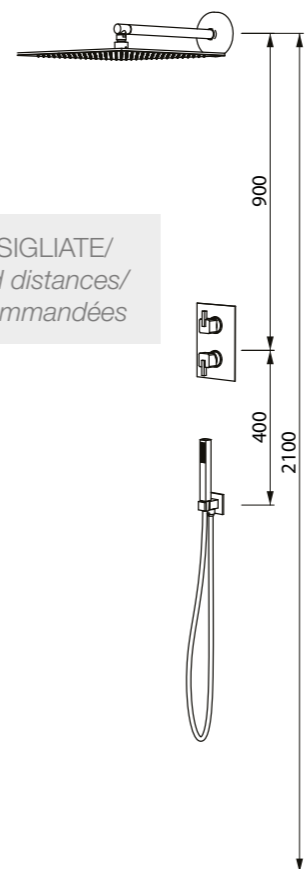

**Ambiente completo tondo.**

Braccio, soffione, termostatico 2 vie, presa acqua c/supp, doccia e flex.

✓ AM 020 T

*Complete round shower setting.*

*Wall arm, shower head, 2 ways thermostatic mixer, water outlet with support, handshower and flexible hose.*

*Ambiance complète ronde.*

*Bras mural, pomme de douche, mitigeur thermostatique 2 sorties, prise d'eau avec support, douchette et flexible.*



VARIANTI / Variations / Variantes

■ CR

**Ambiente completo quadro.**

Braccio, soffione, termostatico 2 vie, presa acqua c/supp, doccia e flex.

✓ AM 420 T

*Complete squared shower setting.*

*Wall arm, shower head, 2 ways thermostatic mixer, water outlet with support, handshower and flexible hose.*

*Ambiance complète carrée.*

*Bras mural, pomme de douche, mitigeur thermostatique 2 sorties, prise d'eau avec support, douchette et flexible.*



VARIANTI / Variations / Variantes

■ CR

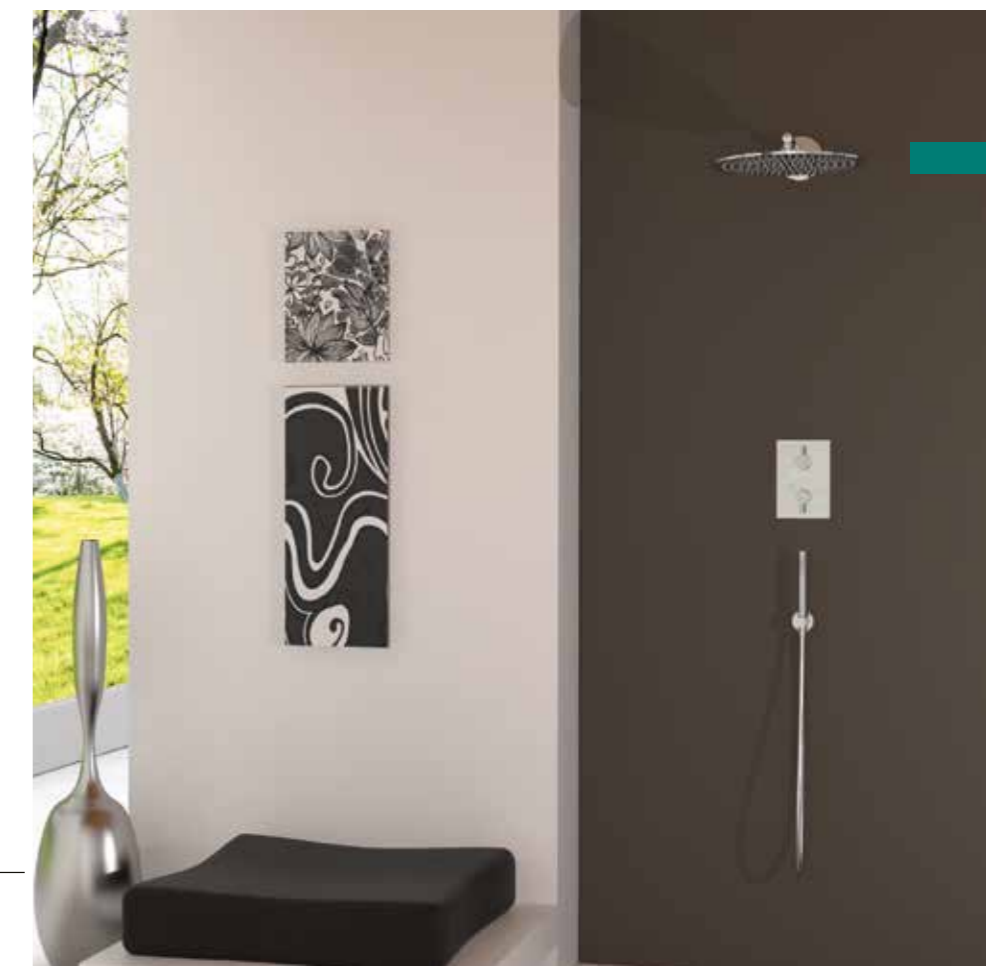

### Ambiente tondo.

Braccio, soffione, miscelatore incasso,  
presa acqua c/sup, doccia e flex, 4 gettini.

✓ AM 030 M

*Complete round shower setting.*

*Wall arm, shower head, concealed mixer, water outlet with support, handshower and flexible hose, 4 body sprays.*

*Ambiance complète ronde.*

*Bras mural, pomme de douche, mitigeur à encastrer, prise d'eau avec support, douchette et flexible, 4 jets latéraux.*



VARIANTI / Variations / Variantes

■ CR

### Ambiente quadro.

Braccio, soffione, miscelatore incasso,  
presa acqua c/sup, doccia e flex, 4 gettini.

✓ AM 430 M

*Complete squared shower setting.*

*Wall arm, shower head, concealed mixer, water outlet with support, handshower and flexible hose, 4 body sprays.*

*Ambiance complète carrée.*

*Bras mural, pomme de douche, mitigeur à encastrer, prise d'eau avec support, douchette et flexible, 4 jets latéraux.*



VARIANTI / Variations / Variantes

■ CR

#### AM 030 / AM 430

- Ø 400 mm
- 400x400 mm
- ✓ H 210 mm
- ✓ G. ½" M

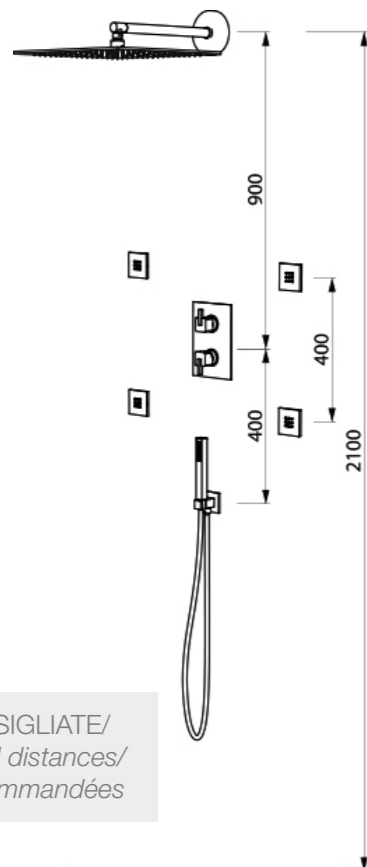

QUOTE CONSIGLIATE/  
Recommended distances/  
Distances recommandées

### Ambiente tondo.

Braccio, soffione, termostatico 3 vie,  
presa acqua c/sup, doccia e flex, 4 gettini.

✓ AM 030 T

*Complete round shower setting.*

*Wall arm, shower head, 3 ways thermostatic mixer, water outlet with support, handshower and flexible hose, 4 body sprays.*

*Ambiance complète ronde.*

*Bras mural, pomme de douche, mitigeur thermostatique 3 sorties, prise d'eau avec support, douchette et flexible, 4 jets latéraux.*



VARIANTI / Variations / Variantes

■ CR

### Ambiente quadro.

Braccio, soffione, termostatico 3 vie,  
presa acqua c/sup, doccia e flex, 4 gettini.

✓ AM 430 T

*Complete squared shower setting.*

*Wall arm, shower head, 3 ways thermostatic mixer, water outlet with support, handshower and flexible hose, 4 body sprays.*

*Ambiance complète carrée.*

*Bras mural, pomme de douche, mitigeur thermostatique 3 sorties, prise d'eau avec support, douchette et flexible, 4 jets latéraux.*



VARIANTI / Variations / Variantes

■ CR



### Ambiente tondo.

Braccio, soffione, termostatico 3 vie,  
presa acqua c/sup, doccia e flex, 6 gettini.

✓ AM 040 T

*Complete round shower setting.*

*Wall arm, shower head, 3 ways thermostatic mixer, water outlet with support, handshower and flexible hose, 6 body sprays.*

*Ambiance complète ronde.*

*Bras mural, pomme de douche, mitigeur thermostatique 3 sorties, prise d'eau avec support, douchette et flexible, 6 jets latéraux.*



VARIANTI / Variations / Variantes

■ CR

### Ambiente quadro.

Braccio, soffione, termostatico 3 vie,  
presa acqua c/sup, doccia e flex, 6 gettini.

✓ AM 440 T

*Complete squared shower setting.*

*Wall arm, shower head, 3 ways thermostatic mixer, water outlet with support, handshower and flexible hose, 6 body sprays.*

*Ambiance complète carrée.*

*Bras mural, pomme de douche, mitigeur thermostatique 3 sorties, prise d'eau avec support, douchette et flexible, 6 jets latéraux.*



VARIANTI / Variations / Variantes

■ CR

#### AM 040 T / AM 440 T

- Ø 400 mm
- 400x400 mm
- ✓ H 210 mm
- ✓ G. ½" M

QUOTE CONSIGLIATE/  
Recommended distances/  
Distances recommandées

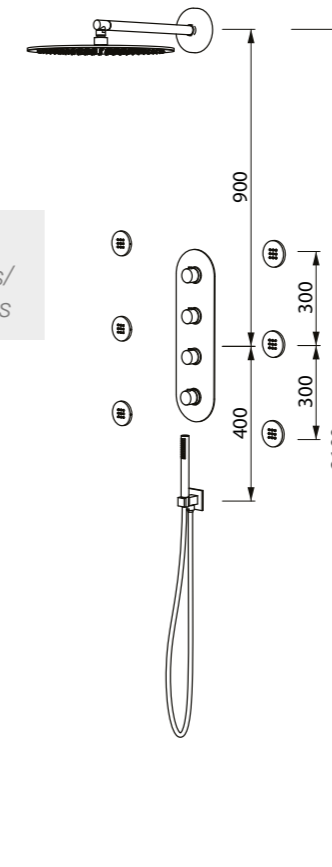



Ambiente completo tondo\*.

✓ AM 001

Shower setting with round accessories\*.

Ambiance ronde\*.



VARIANTI / Variations / Variantes

■ BI / NE / CR

✓ AM 001-PA

Con kit presa acqua e supporto.

With water intake kit and shower holder.

Avec kit raccord et support.

VARIANTI / Variations / Variantes

■ BI / NE / CR

BI - Bianco/White/Blanc NE - Nero/Black/Noir  
CR - Cromo/Chrome

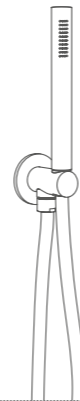

QUOTE CONSIGLIATE/  
Recommended distances/Distances recommandées

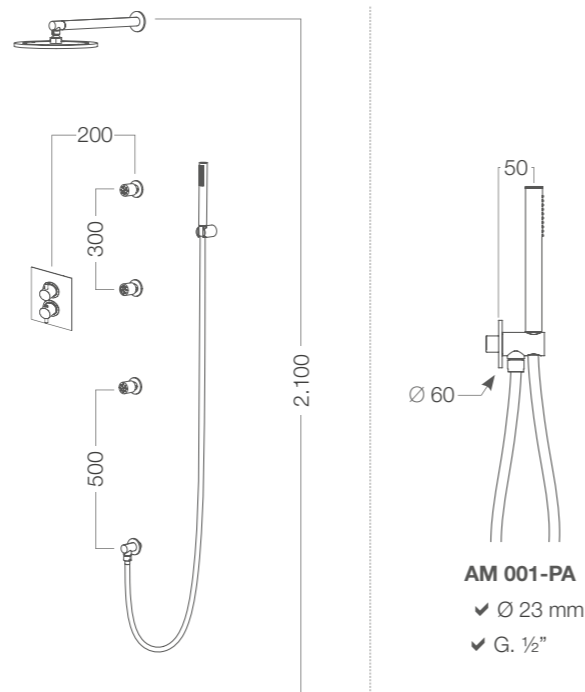

\*Braccio/soffione/doccia/flessibile/supporto/presa acqua/  
3 getti laterali/miscelatore termostatico.

\*Shower arm/shower head/shower/flexible hose/shower holder/water intake/3  
lateral jets/thermostatic mixer.

\*Bras/pomme de douche/douche/flexible/support/prise d'eau/3 jets  
latéraux/mitigeur thermostatique.



Ambiente completo quadro\*.

✓ AM 401

Shower setting with square accessories\*.

Ambiance carrée\*.



VARIANTI / Variations / Variantes

■ BI / NE / CR

✓ AM 401-PA

Con kit presa acqua e supporto.

With water intake kit and shower holder.

Avec kit raccord et support.

VARIANTI / Variations / Variantes

■ BI / NE / CR

BI - Bianco/White/Blanc NE - Nero/Black/Noir  
CR - Cromo/Chrome

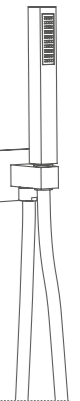

QUOTE CONSIGLIATE/  
Recommended distances/Distances recommandées

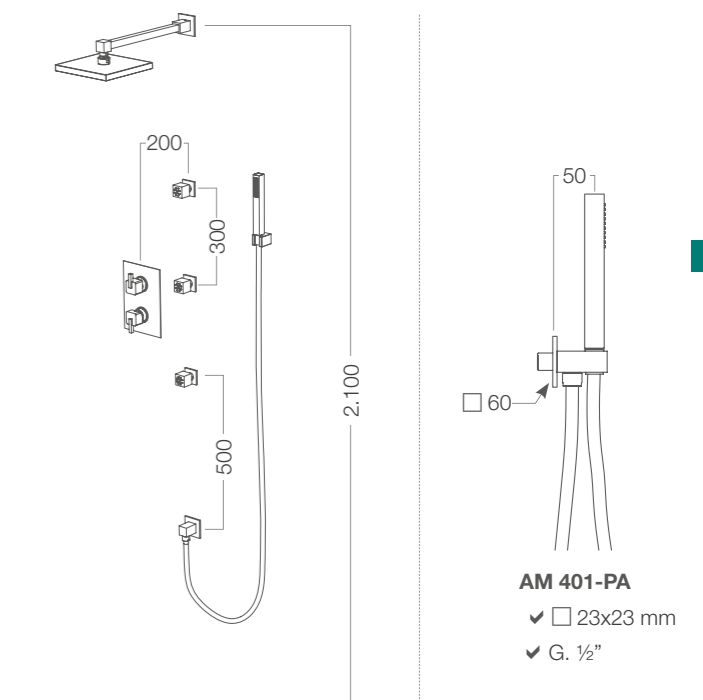

\*Braccio/soffione/doccia/flessibile/supporto/presa acqua/  
3 getti laterali/miscelatore termostatico.

\*Shower arm/shower head/shower/flexible hose/shower holder/water intake/3  
lateral jets/thermostatic mixer.

\*Bras/pomme de douche/douche/flexible/support/prise d'eau/3 jets  
latéraux/mitigeur thermostatique.

La semplicità di utilizzo delle colonne doccia ha fatto crescere l'interesse verso questo prodotto. GRAFFIO propone le proprie versioni quadrate e tonde dove sono i particolari e le soluzioni tecniche a segnare la differenza. La colonna SUPERMINIMAL dà un'interpretazione all'oggetto colonna doccia in stile Graffio. 100% prodotto in Italia.

*The easy to use shower columns have attracted much interest. Graffio proposes their own square and round versions, where technical solution and details make all the difference. The SUPERMINIMAL column gives an individual interpretation of the column in Graffio style. 100% made in Italy.*

*La simplicité d'utilisation des colonnes de douche a accru l'intérêt envers ce produit. Graffio propose, en versions rondes ou carrées, ses propres versions dont les détails et les solutions techniques font la différence. La colonne SUPERMINIMAL est une véritable interprète du style Graffio. Produit 100% en Italie.*

# Colonne doccia

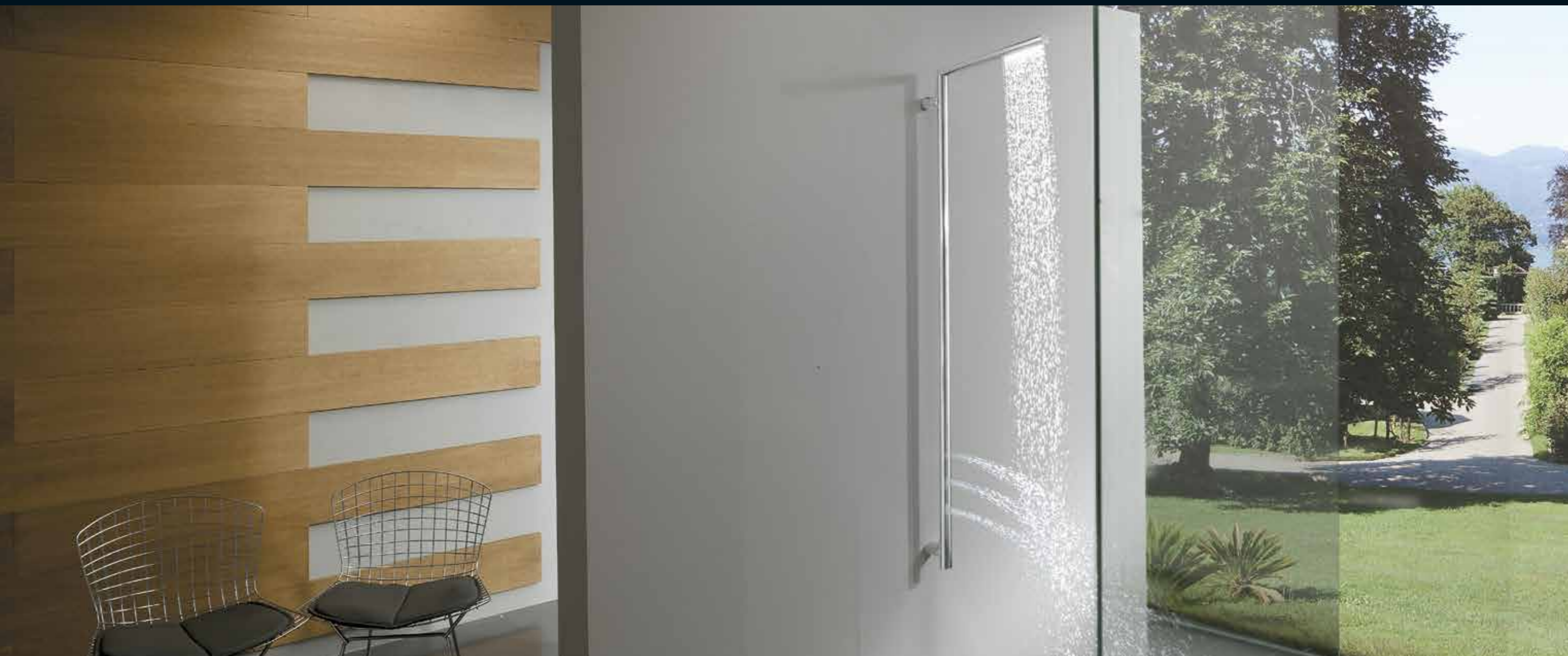



Colonna doccia TELESCOPICA in ottone con miscelatore termostatico, soffione tondo GIPZY Ø 300 mm in acciaio cromato, doccia ACTIVA monogetto in ABS, flessibile ULTRAFLEX 1750 mm.

✓ CT 100

TELESCOPICA brass telescopic shower column with thermostatic mixer, GIPZY round chrome steel showerhead Ø 300 mm, ACTIVA ABS 1 jet hand shower, ULTRAFLEX flexible hose 1750 mm.

Colonne de douche télescopique TELESCOPICA en laiton avec mitigeur thermostatique, pomme de douche ronde GIPZY Ø 300 mm en acier chromé, douchette ACTIVA 1 jet en ABS, flexible ULTRAFLEX 1750 mm.



VARIANTI / Variations / Variantes

■ CR



Colonna doccia AURORA in ottone con miscelatore termostatico, soffione GIPZY Ø 240 mm in acciaio cromato, doccia ELISA monogetto in ottone, flessibile ULTRAFLEX 1750 mm.

✓ CA 100

AURORA brass shower column with thermostatic mixer, GIPZY round 1 jet chrome steel showerhead Ø 240 mm, ELISA brass hand shower, ULTRAFLEX flexible hose 1750 mm.

Colonne de douche AURORA en laiton avec mitigeur thermostatique, pomme de douche ronde GIPZY Ø 240 mm en acier chromé, douchette ELISA 1 jet en laiton, flexible ULTRAFLEX 1750 mm.



VARIANTI / Variations / Variantes

■ CR



Colonna doccia TELESCOPICA in ottone, attacco a parete, soffione tondo GIPZY Ø 300 mm in acciaio cromato, doccia ACTIVA monogetto in ABS, flessibile ULTRAFLEX 1750 mm.

✓ CT 101

TELESCOPICA brass telescopic wall mounted shower column, GIPZY round chrome steel showerhead Ø 300 mm, ACTIVA ABS 1 jet hand shower, ULTRAFLEX flexible hose 1750 mm.

Colonne de douche murale télescopique TELESCOPICA en laiton, pomme de douche ronde GIPZY Ø 300 mm en acier chromé, douchette ACTIVA 1 jet en ABS, flexible ULTRAFLEX 1750 mm.



VARIANTI / Variations / Variantes

■ CR

✓ CT 101-01

Con attacco esterno.

With external water intake.  
Avec raccord externe.

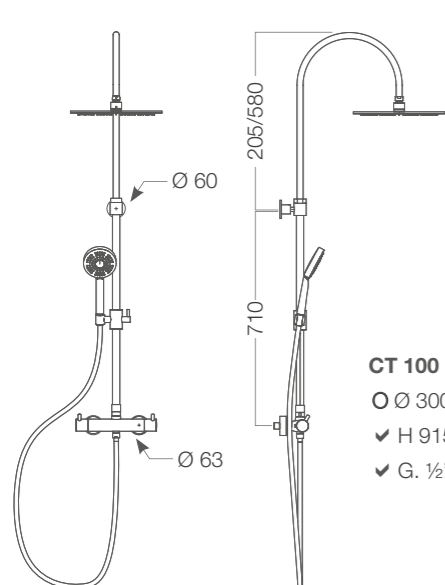
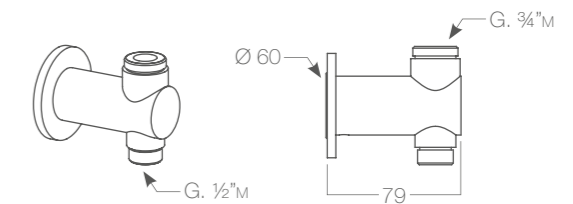

CT 100

○ Ø 300 mm  
✓ H 915/1.290 mm  
✓ G. 1/2" M

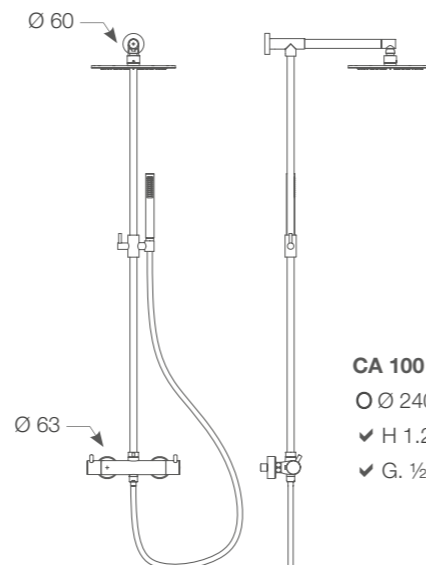

CA 100

○ Ø 240 mm  
✓ H 1.212 mm  
✓ G. 1/2" M

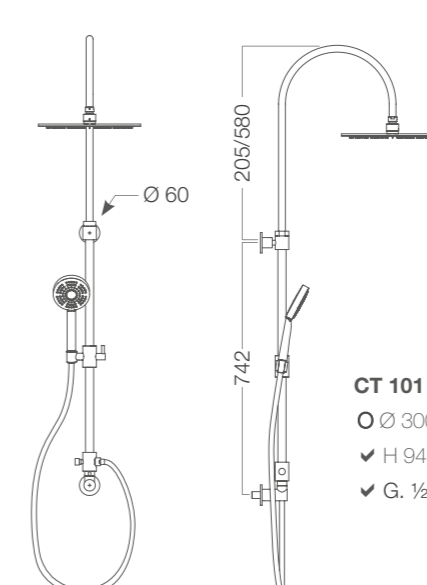

CT 101

○ Ø 300 mm  
✓ H 947/1.322 mm  
✓ G. 1/2" M





Colonna doccia UNICA in ottone, attacco a parete alto, soffione tondo GIPZY Ø 240 mm in acciaio cromato, doccia MINIMALISTA monogetto in ottone, flessibile ULTRAFLEX 1750 mm.

✓ CA 101

UNICA brass high wall mounted shower column, GIPZY chrome steel round showerhead Ø 240 mm, MINIMALISTA brass 1 jet hand shower, ULTRAFLEX flexible hose 1750 mm.

Colonne de douche murale UNICA en laiton, fixation murale haute, pomme de douche ronde GIPZY Ø 240 mm en acier chromé, douchette 1 jet MINIMALISTA en laiton, flexible ULTRAFLEX 1750 mm.



VARIANTI / Variations / Variantes

■ CR



Colonna doccia DADO in ottone con miscelatore termostatico, soffione quadro GIPZY 300x300 mm in acciaio cromato, doccia DADO monogetto in ottone, flessibile ULTRAFLEX 1750 mm.

✓ CD 100

DADO brass shower column with thermostatic mixer, GIPZY square chrome steel showerhead 300x300 mm, DADO brass 1 jet hand shower, ULTRAFLEX flexible hose 1750 mm.

Colonne de douche DADO en laiton avec mitigeur thermostatique, pomme de douche carrée GIPZY 300x300 mm en acier chromé, douchette 1 jet DADO en laiton, flexible ULTRAFLEX 1750 mm.



VARIANTI / Variations / Variantes

■ CR



Colonna doccia DADO in ottone, attacco a parete, soffione quadro GIPZY 300x300 mm in acciaio cromato, doccia DADO in ottone, flessibile ULTRAFLEX 1750 mm.

✓ CD 101

DADO brass wall mounted shower column, GIPZY square chrome steel showerhead 300x300 mm, DADO brass hand shower, ULTRAFLEX flexible hose 1750 mm.

Colonne de douche murale DADO en laiton, pomme de douche GIPZY carrée 300x300 mm en acier chromé, douchette DADO en laiton, flexible ULTRAFLEX 1750 mm.



VARIANTI / Variations / Variantes

■ CR

✓ CD 101-01

Con attacco esterno.  
With external water intake.  
Avec raccord externe.

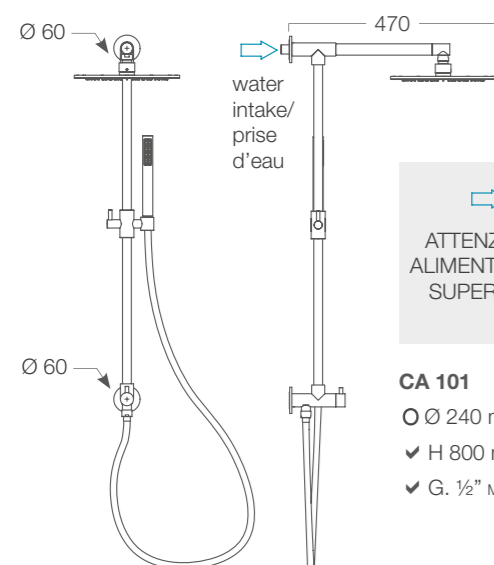
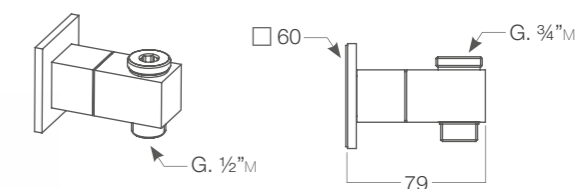

ATTENZIONE!  
ALIMENTAZIONE  
SUPERIORE.

CA 101

- Ø 240 mm
- ✓ H 800 mm
- ✓ G. 1/2" M

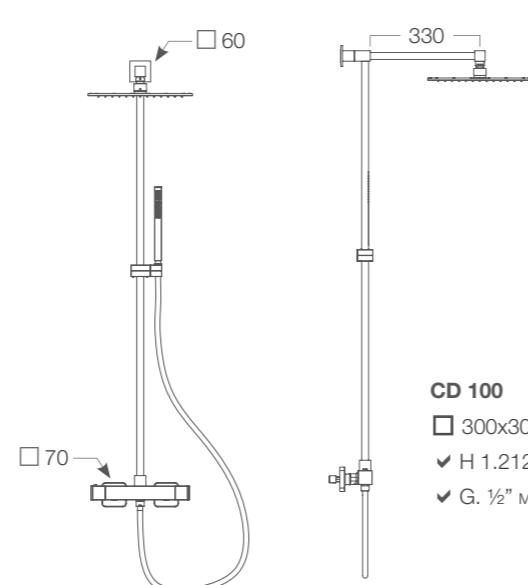

CD 100

- 300x300 mm
- ✓ H 1.212 mm
- ✓ G. 1/2" M

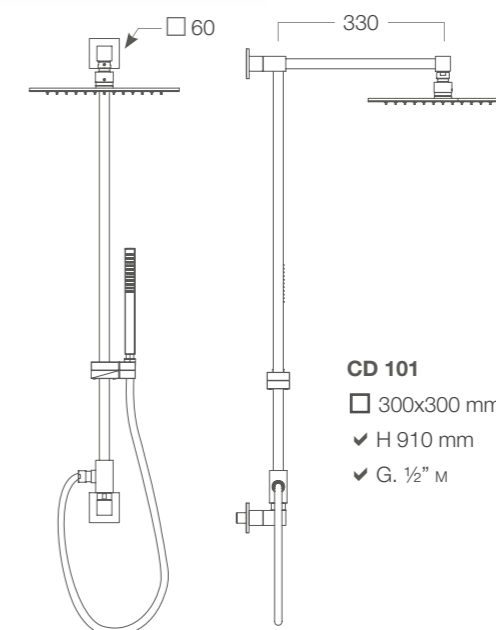

CD 101

- 300x300 mm
- ✓ H 910 mm
- ✓ G. 1/2" M



Colonna doccia quadra SUPERMINIMALISTA  
in ottone, getti laterali.

✓ MQ 190

*SUPERMINIMALISTA square design brass shower  
column with lateral jets.*

*Colonne de douche carrée  
SUPERMINIMALISTA en laiton, jet latéral.*



VARIANTI / Variations / Variantes

■ CR



Colonna doccia ovale SUPERMINIMALISTA  
in ottone, getti laterali.

✓ ME 190

*SUPERMINIMALISTA oval design brass shower  
column with lateral jets.*

*Colonne de douche ovale  
SUPERMINIMALISTA en laiton, jet latéral.*



VARIANTI / Variations / Variantes

■ CR



**MQ 190**

- ✓ □ 20x20 mm
- ✓ H 1.244 mm
- ✓ G. ½" M

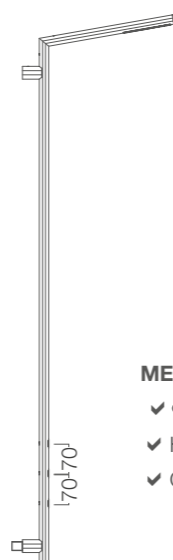

**ME 190**

- ✓ ○ 22x35 mm
- ✓ H 1.245 mm
- ✓ G. ½" M



Fare bene le cose semplici. I saliscendi Graffio si distinguono per la pulizia delle forme, la solidità dei componenti, la lucentezza delle cromature, le doccette perfettamente abbinata. Semplici da coordinare con qualsiasi rubinetteria, possono essere accessoriati con prese acqua dedicate.

*Simple things done well. The sliding wall mount Graffio distinguishes itself by its streamline shape, solid components and shiny chrome finishing, perfectly matching shower heads. Simple to match to any taps and accessories.*

*Bien faire les choses simples. Les complets douche Graffio se distinguent par la pureté des formes, la solidité des composants, l'éclat du chrome, la parfaite combinaison des douches. Leur composition avec la robinetterie est facile. Ils peuvent être complétés par des prises d'eau de style approprié.*

# Saliscendi

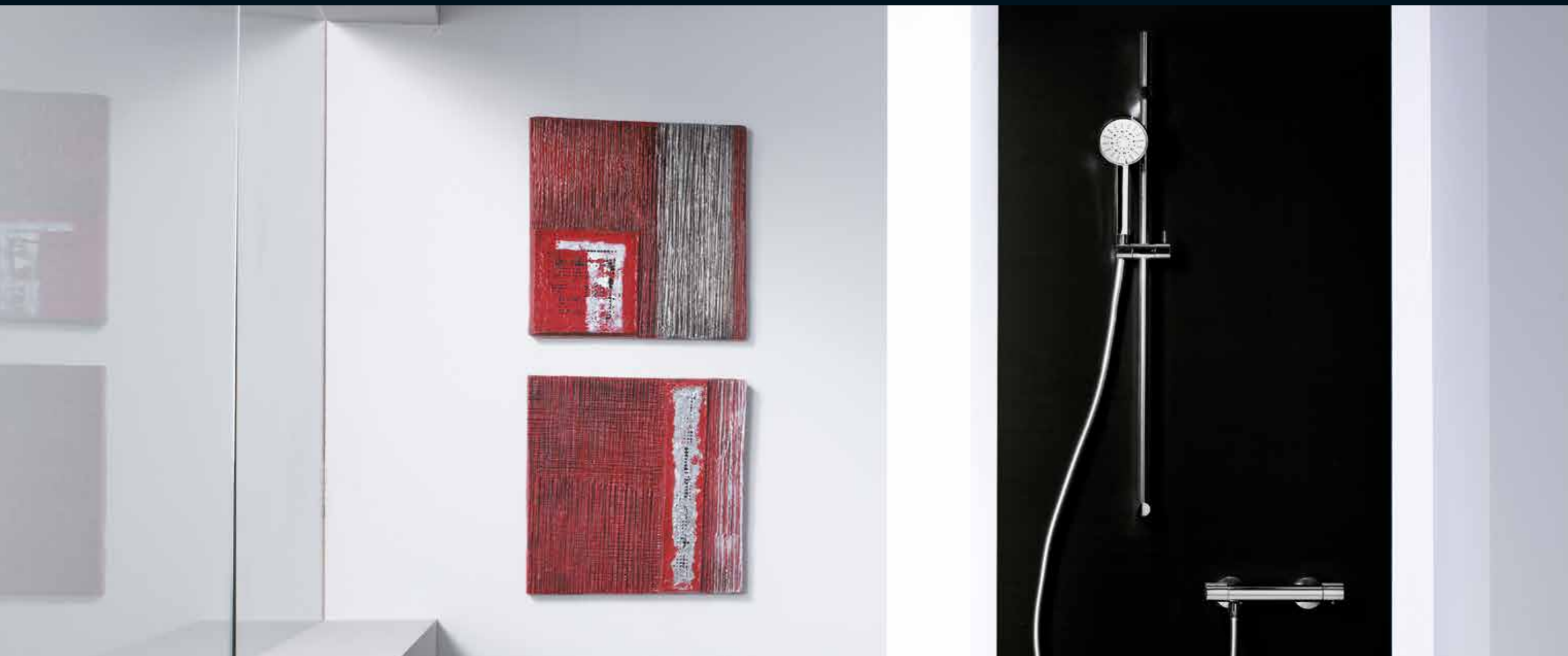

Saliscendi quadro DADO 903 mm in ottone, doccia quadra DADO in ottone, flessibile SILVER 1750 mm.

✓ QD 100

*DADO square brass sliding rail 903 mm, DADO brass hand shower, SILVER flexible hose 1750 mm.*

*Rampe de douche carrée DADO 903 mm en laiton, douchette carrée DADO en laiton, flexible SILVER 1750 mm.*



VARIANTI / Variations / Variantes

■ CR



Saliscendi RETTANGOLARE 903 mm in ottone, doccia RETTANGOLARE in ottone, flessibile SILVER 1750 mm.

✓ RE 100

*RETTANGOLARE rectangular brass sliding rail 903 mm, RETTANGOLARE brass hand shower, SILVER flexible hose 1750 mm.*

*Rampe de douche RETTANGOLARE rectangulaire 903 mm en laiton, douchette rectangulaire RETTANGOLARE en laiton, flexible SILVER 1750 mm.*



VARIANTI / Variations / Variantes

■ CR



Saliscendi tondo LIMA 890 mm in ottone, doccia THETA in ABS, flessibile SILVER 1750 mm.

✓ LM 100

*LIMA round brass sliding rail 890 mm, THETA ABS handshower, SILVER flexible hose 1750 mm.*

*Rampe de douche ronde LIMA 890 mm en laiton, douchette THETA en ABS, flexible SILVER 1750 mm.*



VARIANTI / Variations / Variantes

■ CR



Saliscendi tondo LIMA 890 mm in ottone con miscelatore termostatico, doccia THETA in ABS, flessibile SILVER 1750 mm.

✓ LM 800

*LIMA round brass sliding rail 890 mm with thermostatic mixer, THETA ABS handshower, SILVER flexible hose 1750 mm.*

*Rampe de douche ronde LIMA 890 mm en laiton avec mitigeur thermostatique, douchette THETA en ABS, flexible SILVER 1750 mm.*



VARIANTI / Variations / Variantes

■ CR

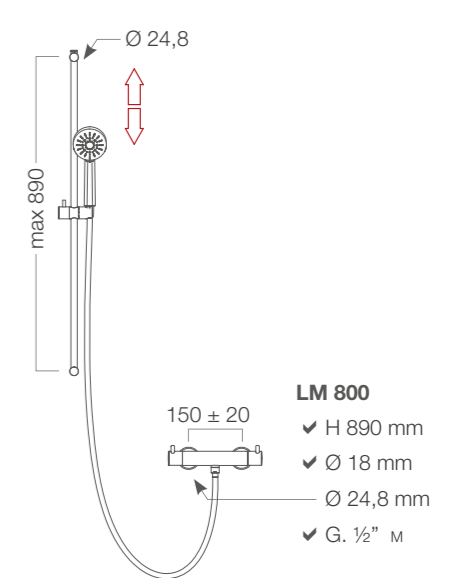
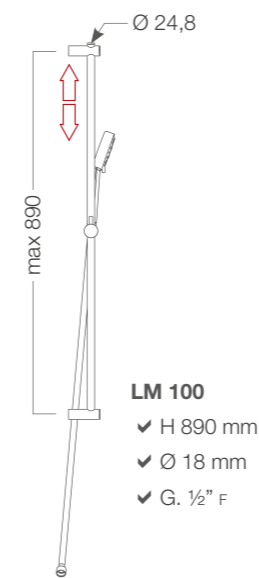
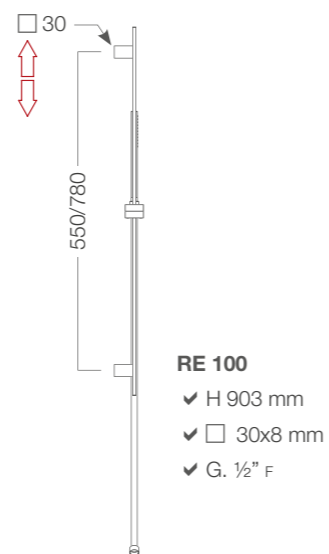
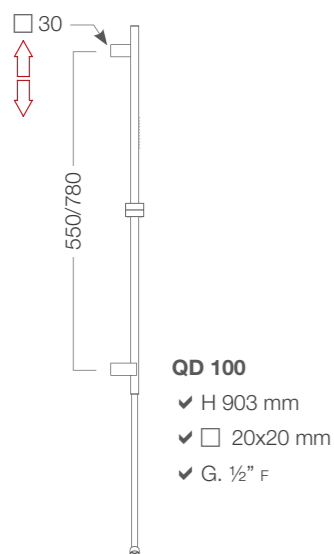



**Saliscendi quadro DADO 903 mm in ottone con miscelatore termostatico, doccia quadra DADO in ottone, flessibile SILVER 1750 mm.**

✓ QD 800

*DADO square brass sliding rail 903 mm with thermostatic mixer, DADO brass hand shower, SILVER flexible hose 1750 mm.*

*Rampe de douche carrée DADO 903 mm en laiton avec mitigeur thermostatique, douchette carrée DADO en laiton, flexible SILVER 1750 mm.*



VARIANTI / Variations / Variantes

■ CR



**Saliscendi RETTANGOLARE 903 mm in ottone con miscelatore termostatico, doccia RETTANGOLARE in ottone, flessibile SILVER 1750 mm.**

✓ RE 800

*RETTANGOLARE rectangular brass sliding rail 903 mm with thermostatic mixer, RETTANGOLARE brass hand shower, SILVER flexible hose 1750 mm.*

*Rampe de douche rectangulaire RETTANGOLARE 903 mm en laiton avec mitigeur thermostatique, douchette rectangulaire RETTANGOLARE en laiton, flexible SILVER 1750 mm.*



VARIANTI / Variations / Variantes

■ CR



**Saliscendi quadro DADO 903 mm in ottone.**

✓ QD 190

*DADO square brass sliding rail 903 mm.*

*Rampe de douche carrée DADO 903 mm en laiton.*

VARIANTI / Variations / Variantes

■ CR



**Saliscendi RETTANGOLARE 903 mm in ottone.**

✓ RE 190

*RETTANGOLARE rectangular brass sliding rail 903 mm.*

*Rampe de douche rectangulaire RETTANGOLARE 903 mm en laiton.*

VARIANTI / Variations / Variantes

■ CR

**Saliscendi tondo LIMA 890 mm in ottone.**

✓ LM 190

*LIMA round brass sliding rail 890 mm.*

*Rampe de douche ronde LIMA 890 mm en laiton.*

VARIANTI / Variations / Variantes

■ CR

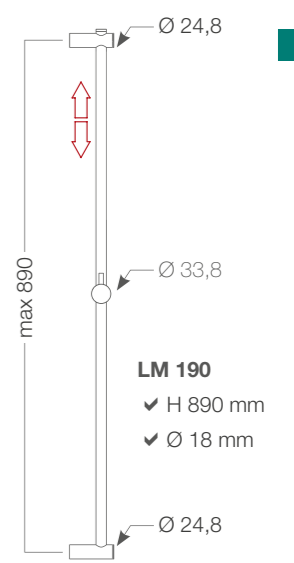
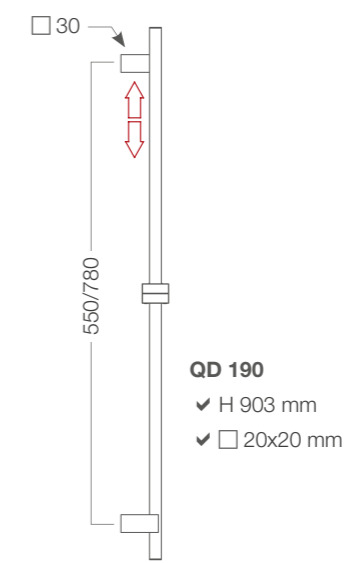
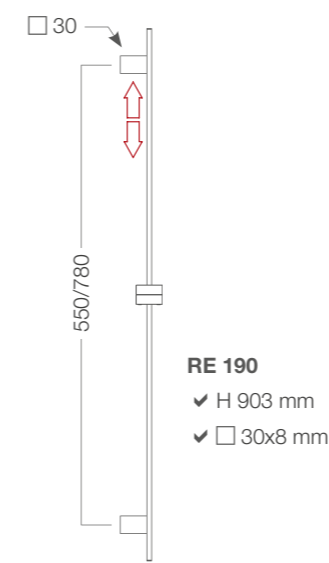
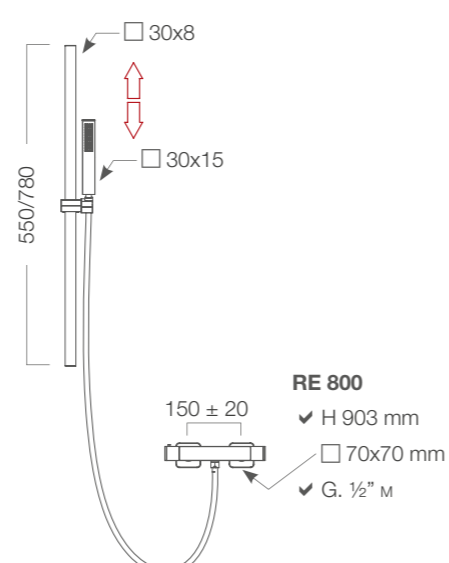
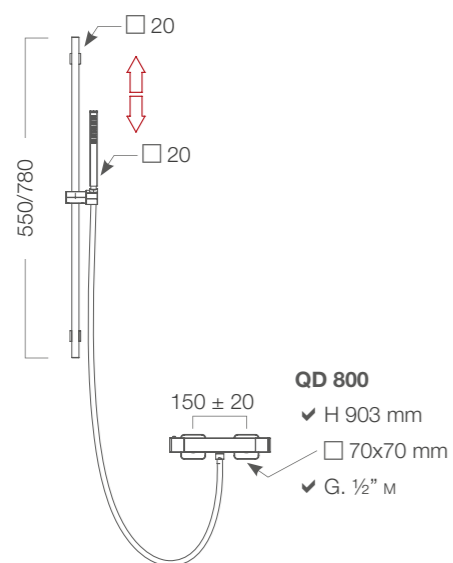

# Body Jet





Getto laterale quadro BODY JET 75x75 mm, nebulizzatore, ad incasso.

✓ BJ 421

BODY JET square built-in lateral jet 75x75 mm, mist spray.

Jet latéral carré BODY JET encastré 75x75 mm, brumiseur.



VARIANTI / Variations / Variantes

■ ORO / BS / RS / ORO-R / NS / CR / NEO / BIO



Getto laterale quadro BODY JET 75x75 mm con angoli raggiati, nebulizzatore, ad incasso.

✓ BJ 321

BODY JET square built-in lateral jet 75x75 mm with smooth angles, mist spray.

Jet latéral carré BODY JET encastré 75x75 mm avec les angles arrondis, brumiseur.



VARIANTI / Variations / Variantes

■ ORO / BS / RS / ORO-R / NS / CR / NEO / BIO



Getto laterale rotondo BODY JET Ø 75 mm, nebulizzatore, ad incasso.

✓ BJ 021

BODY JET round built-in lateral jet Ø 75 mm, mist spray.

Jet latéral rond BODY JET encastré Ø 75 mm, brumiseur.



VARIANTI / Variations / Variantes

■ ORO / BS / RS / ORO-R / NS / CR / NEO / BIO



Getto laterale quadro BODY JET 75x75 mm, pioggia, ad incasso.

✓ BJ 411

BODY JET square built-in lateral jet 75x75 mm, rain fall.

Jet latéral carré BODY JET encastré 75x75 mm, pluie.



VARIANTI / Variations / Variantes

■ ORO / BS / RS / ORO-R / NS / CR / NEO / BIO



Getto laterale quadro BODY JET 75x75 mm con angoli raggiati, pioggia, ad incasso.

✓ BJ 311

BODY JET square built-in lateral jet 75x75 mm with smooth angles, rain.

Jet latéral carré BODY JET encastré 75x75 mm avec les angles arrondis, pluie.



VARIANTI / Variations / Variantes

■ ORO / BS / RS / ORO-R / NS / CR / NEO / BIO



Getto laterale rotondo BODY JET Ø 75 mm, pioggia, ad incasso.

✓ BJ 011

BODY JET round built-in lateral jet Ø 75 mm, rain fall.

Jet latéral rond BODY JET encastré Ø 75 mm, pluie.



VARIANTI / Variations / Variantes

VARIANTI / Variations / Variantes

■ ORO / BS / RS / ORO-R / NS / CR / NEO / BIO

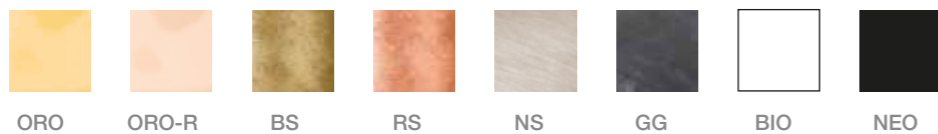

ORO - Oro/Gold/Or ORO-R - Oro rosa/Rose gold/Or rose

BS - Bronzo spazzolato/Brushed brass/Laiton brossé RS - Rame spazzolato/Brushed copper/Cuivre brossé

NS - Nickel spazzolato/Brushed nickel/Nickel brossé GG - Grafite/Graphite CR - Cromo/Chrome

BIO - Bianco opaco/Matte white/Blanche mate NEO - Nero opaco/Matte black/Noire mate

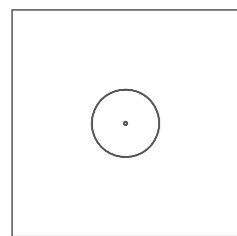

BJ 421

✓ L/H 75 mm  
✓ G. 1/2" M

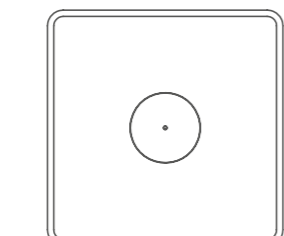

BJ 321

✓ L/H 75 mm  
✓ G. 1/2" M

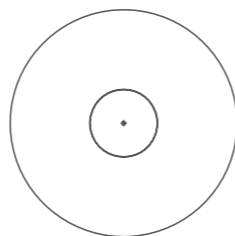

BJ 021

✓ Ø 75 mm  
✓ G. 1/2" M

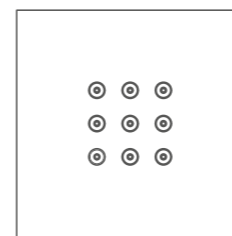

BJ 411

✓ L/H 75 mm  
✓ G. 1/2" M

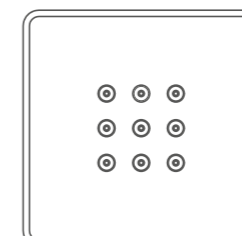

BJ 311

✓ L/H 75 mm  
✓ G. 1/2" M

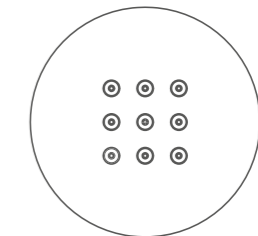

BJ 011

✓ Ø 75 mm  
✓ G. 1/2" M



Getto laterale rotondo BODY JET orientabile, Ø 35 mm, pioggia.

✓ BJ 012

BODY JET round lateral adjustable jet Ø 35 mm, rain.

Jet latéral rond BODY JET réglable Ø 35 mm, pluie.



VARIANTI / Variations / Variantes

■ CR



Getto laterale quadro BODY JET orientabile, 35x35 mm, pioggia.

✓ BJ 412

BODY JET square lateral adjustable jet 35x35 mm, rain.

Jet latéral carré BODY JET réglable 35x35 mm, pluie.



VARIANTI / Variations / Variantes

■ CR



Getto laterale ovale BODY JET orientabile, 50x35 mm, pioggia.

✓ BJ 312

BODY JET oval lateral adjustable jet 50x35 mm, rain.

Jet latéral ovale BODY JET réglable 50x35 mm, pluie.



VARIANTI / Variations / Variantes

■ CR



CR - Cromo/Chrome

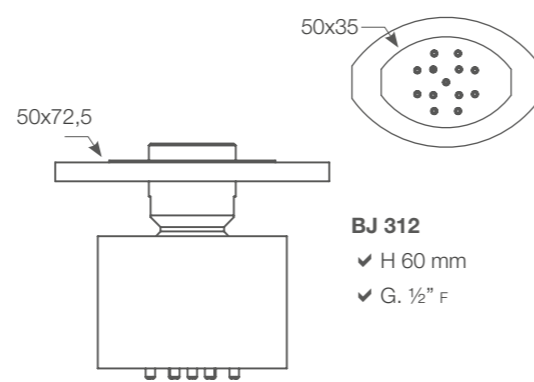
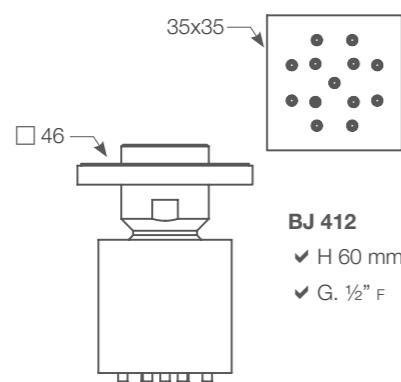
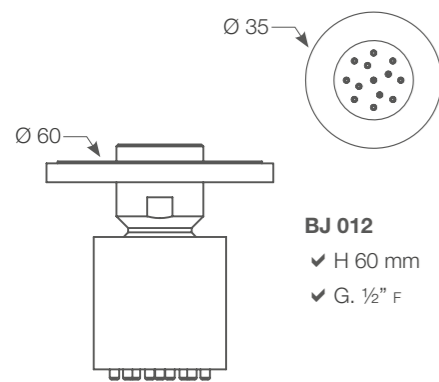



# Termostatici





**Termostatico incasso 3 vie tondo.**  
✓ TET 003

Built-in round shower mixer, 3 ways.  
Mitigeur douche encastré 3 voies, rond.

VARIANTI / Variations / Variantes

■ BI / NE / CR



**Termostatico incasso 3 vie quadro.**  
✓ TEQ 003

Built-in square shower mixer, 3 ways.  
Mitigeur douche encastré 3 voies, carré.

VARIANTI / Variations / Variantes

■ BI / NE / CR



**Termostatico incasso 5 vie tondo.**  
✓ TET 007-01

Built-in round shower mixer, 5 ways.  
Mitigeur douche encastré 5 voies, rond.

VARIANTI / Variations / Variantes

■ CR



**Termostatico incasso 5 vie quadro.**  
✓ TEQ 007

Built-in square shower mixer, 5 ways.  
Mitigeur douche encastré 5 voies, carré.

VARIANTI / Variations / Variantes

■ CR



BI - Bianco/White/Blanc NE - Nero/Black/Noir CR - Cromo/Chrome

**TET 003**

- ✓ L 150 mm
- ✓ H 200 mm
- ✓ G. 1/2" F

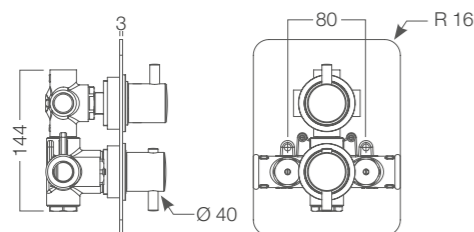

**TEQ 003**

- ✓ L 150 mm
- ✓ H 200 mm
- ✓ G. 1/2" F

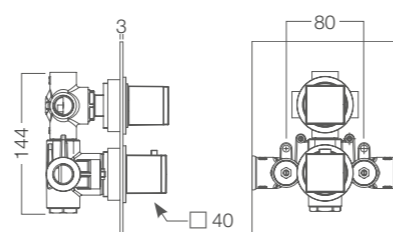

**TET 007-01**

- ✓ L 160 mm
- ✓ H 220 mm
- ✓ G. 1/2" F

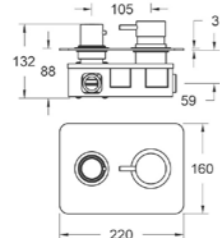

**TEQ 007**

- ✓ L 160 mm
- ✓ H 220 mm
- ✓ G. 1/2" F

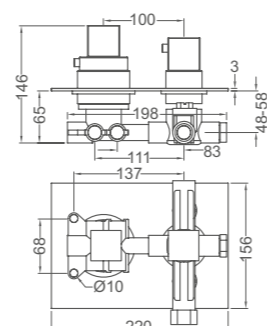

**Termostatico incasso 2 vie tondo.**  
✓ TET 021

Built-in round shower mixer, 2 ways.  
Mitigeur douche encastré 2 voies, rond.

VARIANTI / Variations / Variantes

■ CR



**Termostatico incasso 2 vie quadro.**  
✓ TEQ 021

Built-in square shower mixer, 2 ways.  
Mitigeur douche encastré 2 voies, carré.

VARIANTI / Variations / Variantes

■ CR



**Termostatico incasso 3 vie tondo.**  
✓ TET 023

Built-in square shower mixer, 3 ways.  
Mitigeur douche encastré 3 voies, rond.

VARIANTI / Variations / Variantes

■ CR



**Termostatico incasso 3 vie quadro.**  
✓ TEQ 023

Built-in square shower mixer, 3 ways.  
Mitigeur douche encastré 3 voies, carré.

VARIANTI / Variations / Variantes

■ CR

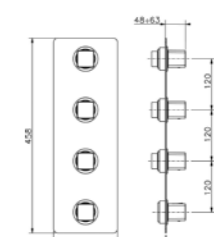
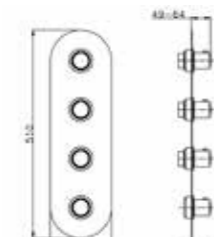
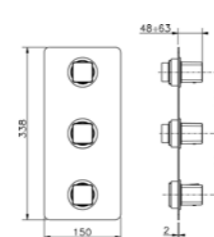
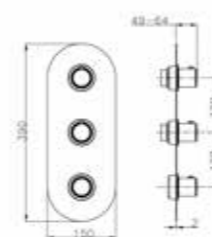
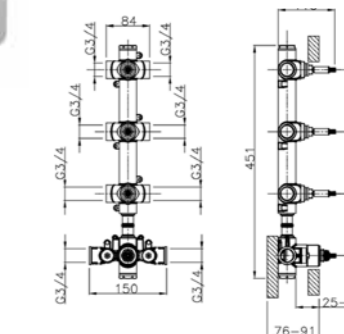
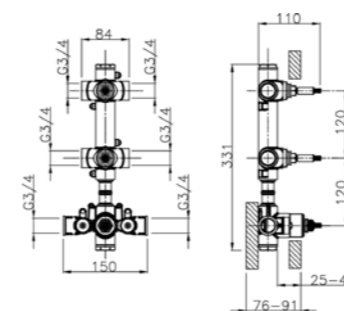

**TET 021**

- ✓ L 150 mm
- ✓ H 390 mm
- ✓ G. 1/2" F

**TEQ 021**

- ✓ L 150 mm
- ✓ H 338 mm
- ✓ G. 1/2" F

**TET 023**

- ✓ L 150 mm
- ✓ H 510 mm
- ✓ G. 1/2" F

**TEQ 023**

- ✓ L 150 mm
- ✓ H 458 mm
- ✓ G. 1/2" F

Sia nei bagni delle strutture ricettive che nei bagni privati, l'attenzione all'igiene personale è sempre maggiore. L'esperienza Nuova Osmo nella produzione di doccette igieniche facilita Graffio nella proposta di shut-off e iperscopini. Le prese con "acqua-stop" brevettate ne permettono un utilizzo sempre sicuro.

*Within both private bathrooms found in the home and bathrooms within public structures, attention to personal hygiene are of utmost importance. The experience of Nuova Osmo in the production of hygienic shower jets has given Graffio an advantage in the production of their innovative product "shut-off" and "iperscopini" (hydro brush). The jets with the patented "acqua-stop" function, make for a secure utilization.*

*Autant dans les salles d'eau des collectivités que dans la propre salle de bain, l'hygiène personnelle est un facteur croissant. L'expérience que Nuova Osmo a consolidées dans la production des douchettes hygiéniques sont, pour Graffio, les atouts déterminants des «shut-off» et des hydro-brosses. Les prises d'eau brevetées qui ouvrent et ferment l'eau rendent leur utilisation facile et sûre.*

# Docce Igieniche





**Doccia igienica a pulsante STELLA**  
tonda in ottone, supporto in ABS,  
flessibile SILVER 1200 mm.

✓ SH 701

*STELLA brass round hygienic shower  
with trigger, ABS shower holder,  
SILVER flexible hose 1200 mm.*

*Douchette hygiénique ronde à levier  
STELLA en laiton, support en ABS,  
flexible SILVER 1200 mm.*

VARIANTI / Variations / Variantes

■ ORO / BS / RS / NS / CR / NEO / BIO

**Doccia igienica a pulsante AIDA**  
tonda in ABS, supporto  
in ABS, flessibile SILVER 1200 mm.

✓ SH 703

*AIDA brass and ABS round hygienic  
shower with push button, ABS shower  
holder, SILVER flexible hose 1200 mm.*

*Douchette hygiénique ronde à poussoir  
AIDA en laiton et en ABS, support  
en ABS, flexible SILVER 1200 mm.*

VARIANTI / Variations / Variantes

■ ORO / BS / RS / NS / CR / NEO / BIO



**Doccia igienica a pulsante NAMIR**  
quadra in ottone, supporto in ABS,  
flessibile SILVER 1200 mm.

✓ SH 702

*NAMIR brass square hygienic shower  
with trigger, ABS shower holder,  
SILVER flexible hose 1200 mm.*

*Douchette hygiénique carrée à levier  
NAMIR en laiton, support en ABS,  
flexible SILVER 1200 mm.*

VARIANTI / Variations / Variantes

■ ORO / BS / RS / NS / CR / NEO / BIO

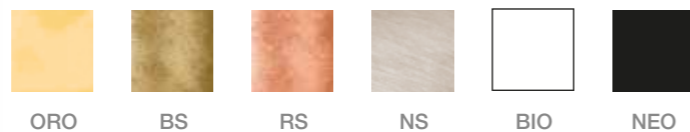

ORO - Oro/Gold/Or BS - Bronzo spazzolato/Brushed brass/Laiton brossé RS - Rame spazzolato/  
Brushed copper/Cuivre brossé NS - Nickel spazzolato/Brushed nickel/Nickel brossé BIO - Bianco  
opaco/Matte white/Blanche mate NEO - Nero opaco/Matte black/Noire mate CR - Cromo/Chrome

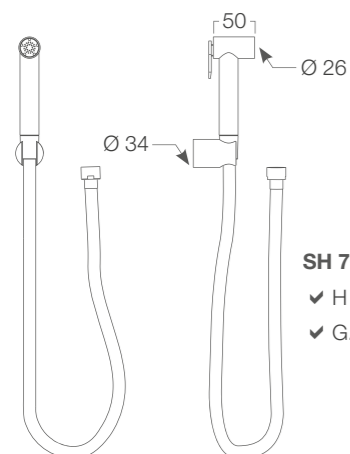

**SH 701**  
✓ H 128 mm  
✓ G. 1/2" F

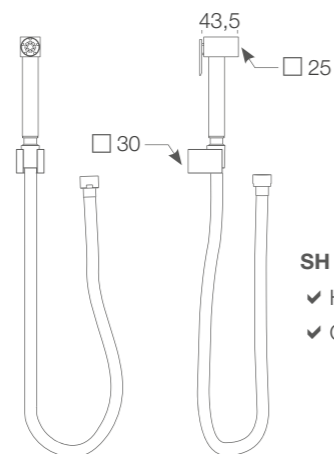

**SH 702**  
✓ H 143,5 mm  
✓ G. 1/2" F

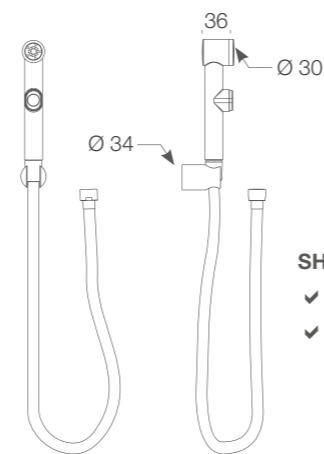

**SH 703**  
✓ H 167 mm  
✓ G. 1/2" F



**Preso acqua con supporto tondo e valvola di  
sicurezza, doccia igienica a pulsante STELLA**  
tonda in ottone, flessibile SILVER 1200 mm.

✓ SH 801

*Water intake with round shower holder with safety  
valve, STELLA brass round hygienic shower  
with trigger, SILVER flexible hose 1200 mm.*

*Prise d'eau avec support rond avec valve de  
sécurité, douchette hygiénique ronde à levier  
STELLA en laiton, flexible SILVER 1200 mm.*



VARIANTI / Variations / Variantes

■ ORO / BS / RS / NS / CR / NEO / BIO



**Preso acqua con supporto quadro e valvola di  
sicurezza, doccia igienica a pulsante NAMIR**  
quadra in ottone, flessibile SILVER 1200 mm.

✓ SH 802

*Water intake with square shower holder with  
safety valve, NAMIR brass square hygienic shower  
with trigger, SILVER flexible hose 1200 mm.*

*Prise d'eau avec support carré avec valve de  
sécurité, douchette hygiénique carrée à levier  
NAMIR en laiton, flexible SILVER 1200 mm.*



VARIANTI / Variations / Variantes

■ ORO / BS / RS / NS / CR / NEO / BIO

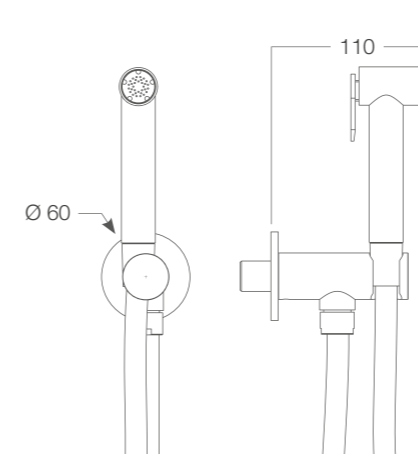

**SH 801**  
✓ G. 1/2" M

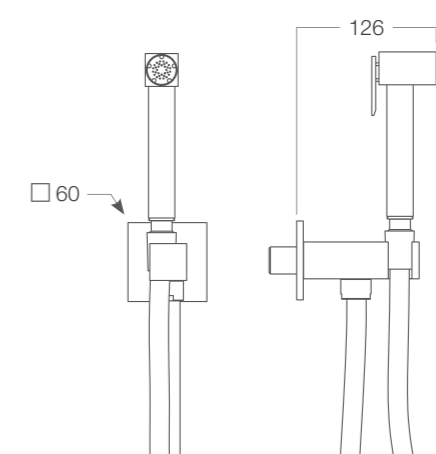

**SH 802**  
✓ G. 1/2" M



Presacqua PADLOCK monoacqua con supporto tondo e comando di sicurezza, doccia igienica a pulsante STELLA in ottone, flessibile ULTRAFLEX 1200 mm.

✓ KSPAT100-07

*PADLOCK water inlet with round security holder, STELLA brass hygienic shower with trigger, ULTRAFLEX flexible hose 1200 mm.*

*Prise d'eau PADLOCK avec support rond et déclencheur de sécurité, douchette hygiénique STELLA en laiton avec poussoir, flexible ULTRAFLEX 1200 mm.*

VARIANTI / Variations / Variantes

■ ORO / BS / RS / NS / CR / NEO / BIO

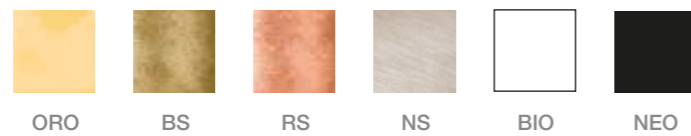

ORO - Oro/Gold/Or BS - Bronzo spazzolato/Brushed brass/Laiton brossé RS - Rame spazzolato/Brushed copper/Cuivre brossé NS - Nickel spazzolato/Brushed nickel/Nickel brossé BIO - Bianco opaco/Matte white/Blanche mate NEO - Nero opaco/Matte black/Noire mate CR - Cromo/Chrome



Presacqua PADLOCK monoacqua con supporto quadro e comando di sicurezza, doccia igienica a pulsante NAMIR in ottone, flessibile ULTRAFLEX 1200 mm.

✓ KSPAQ100-09

*PADLOCK water inlet with square security holder, NAMIR brass hygienic shower with trigger, ULTRAFLEX flexible hose 1200 mm.*

*Prise d'eau PADLOCK avec support carré et déclencheur de sécurité, douchette hygiénique NAMIR en laiton avec poussoir, flexible ULTRAFLEX 1200 mm.*

VARIANTI / Variations / Variantes

■ ORO / BS / RS / NS / CR / NEO / BIO



Miscelatore shut-off progressivo ad incasso PADLOCK con supporto tondo e comando di sicurezza, doccia igienica a pulsante STELLA in ottone, flessibile ULTRAFLEX 1200 mm.

✓ KSPAT101-07

*PADLOCK shut-off mixer with progressive cartridge and round security holder, STELLA brass hygienic shower with trigger, ULTRAFLEX flexible hose 1200 mm.*

*Mitigeur shut-off PADLOCK progressif encastré avec support rond et et déclencheur de sécurité, douchette hygiénique STELLA en laiton avec poussoir, flexible ULTRAFLEX 1200 mm.*

VARIANTI / Variations / Variantes

■ ORO / BS / RS / NS / CR / NEO / BIO

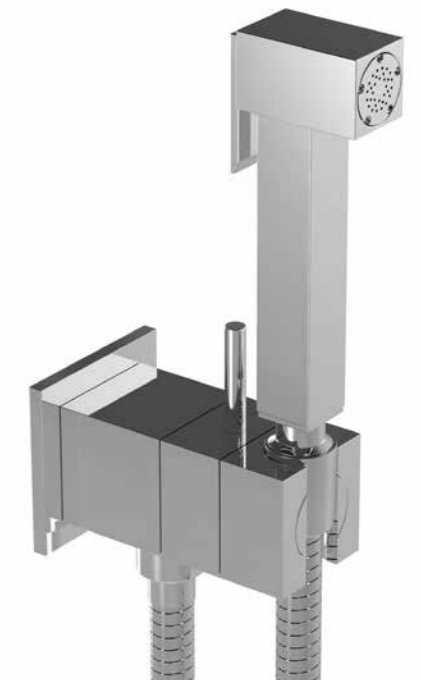

Miscelatore shut-off progressivo ad incasso PADLOCK con supporto quadro e comando di sicurezza, doccia igienica a pulsante NAMIR in ottone, flessibile ULTRAFLEX 1200 mm.

✓ KSPAQ101-09

*PADLOCK shut-off mixer with progressive cartridge and square security holder, NAMIR brass hygienic shower with trigger, ULTRAFLEX flexible hose 1200 mm.*

*Mitigeur shut-off PADLOCK progressif encastré avec support carré et et déclencheur de sécurité, douchette hygiénique NAMIR en laiton avec poussoir, flexible ULTRAFLEX 1200 mm.*

VARIANTI / Variations / Variantes

■ ORO / BS / RS / NS / CR / NEO / BIO

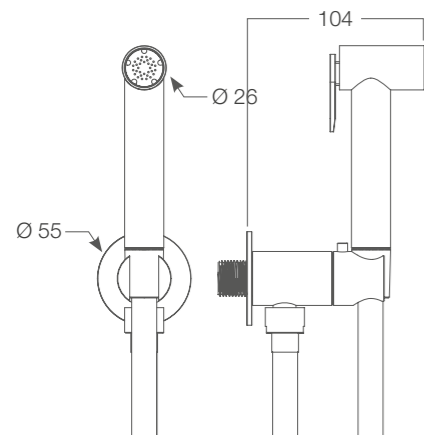

**KSPAT100-07**  
✓ H 128 mm  
✓ G. 1/2"

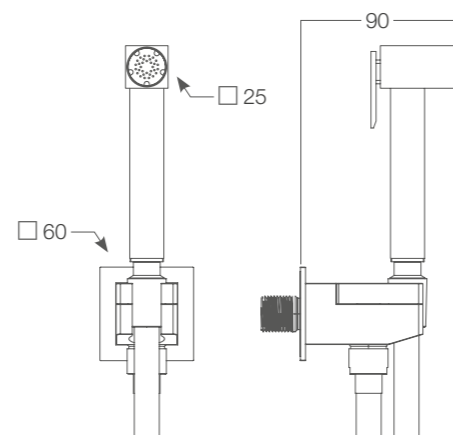

**KSPAQ100-09**  
✓ H 143,5 mm  
✓ G. 1/2"

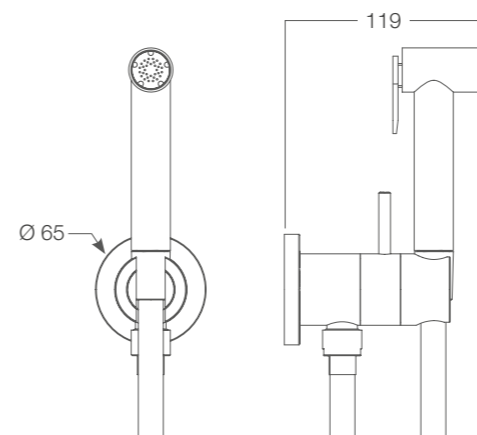

**KSPAT101-07**  
✓ H 128 mm  
✓ G. 1/2"

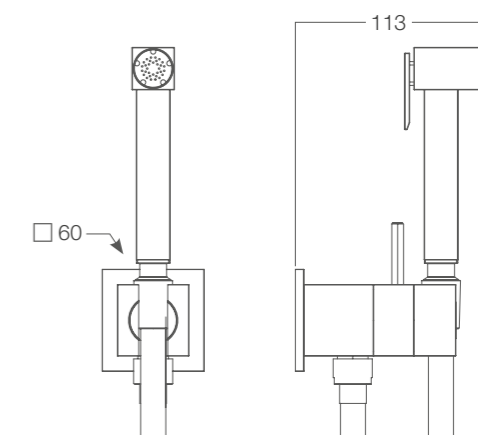

**KSPAQ101-09**  
✓ H 143,5 mm  
✓ G. 1/2"

Miscelatore PRIMA incasso con supporto in ottone e piastra rettangolare 190x110mm, doccia igienica a pulsante STELLA tonda in ottone, flessibile SILVER 1200 mm.

✓ SH 811

*PRIMA built-in mixer with brass shower holder and rectangular plate 190x110 mm, STELLA brass round hygienic shower with trigger, SILVER flexible hose 1200 mm.*

*Mitigeur PRIMA encastré avec support en laiton et plaque rectangulaire 190x110 mm, douchette hygiénique ronde à levier STELLA en laiton, flexible SILVER 1200 mm.*

VARIANTI / Variations / Variantes

■ ORO / BS / RS / NS / CR / NEO / BIO

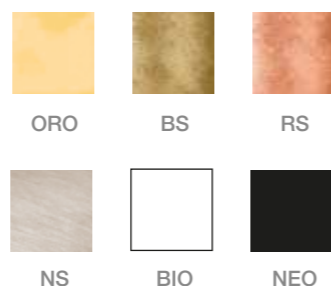

ORO - Oro/Gold/Or BS - Bronzo spazzolato/Brushed brass/Laiton brossé  
 RS - Rame spazzolato/Brushed copper/Cuivre brossé  
 NS - Nickel spazzolato/Brushed nickel/Nickel brossé  
 BIO - Bianco opaco/Matte white/Blanche mate  
 NEO - Nero opaco/Matte black/Noire mate CR - Cromo/Chrome

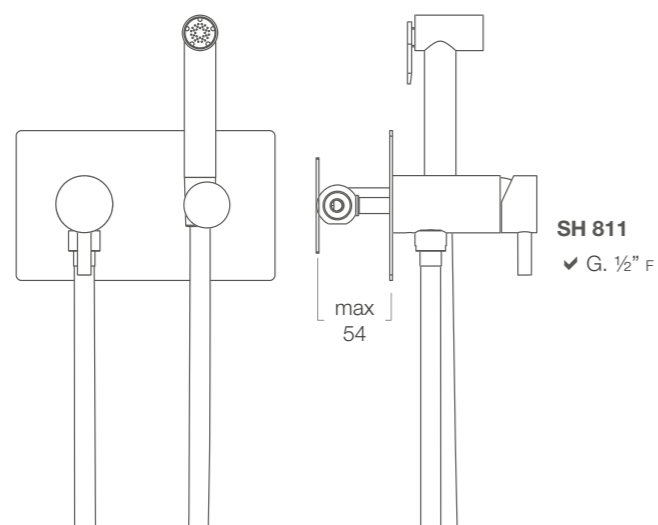

Miscelatore PRIMA PLUS incasso con supporto in ottone e piastra rettangolare 190x110 mm, doccia igienica a pulsante NAMIR quadra in ottone, flessibile SILVER 1200 mm.

✓ SH 812

*PRIMA PLUS built-in mixer with brass shower holder and rectangular plate 190x110 mm, NAMIR brass square hygienic shower with trigger, SILVER flexible hose 1200 mm.*

*Mitigeur PRIMA PLUS encastré avec support en laiton et plaque rectangulaire 190x110 mm, douchette hygiénique carrée à levier NAMIR en laiton, flexible SILVER 1200 mm.*

VARIANTI / Variations / Variantes

■ ORO / BS / RS / NS / CR / NEO / BIO

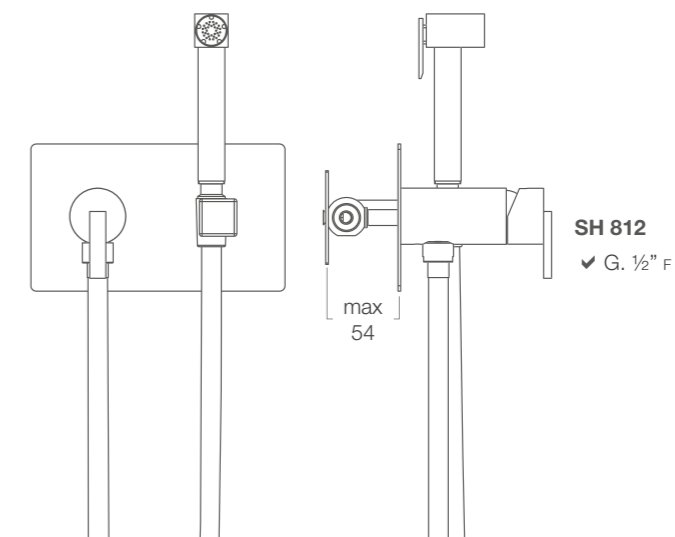

Miscelatore PRIMA PLUS incasso con supporto in ottone e piastra quadra 110 mm, doccia igienica a pulsante STELLA tonda in ottone, flessibile SILVER 1200 mm.

✓ SH 821

*PRIMA PLUS built-in mixer with brass shower holder and square plate 110 mm, STELLA brass round hygienic shower with trigger, SILVER flexible hose 1200 mm.*

*Mitigeur PRIMA PLUS encastré avec support en laiton et plaque carrée 110 mm, douchette hygiénique ronde à levier STELLA en laiton, flexible SILVER 1200 mm.*

VARIANTI / Variations / Variantes

■ ORO / BS / RS / NS / CR / NEO / BIO



✓ SH 821 ABS

Con supporto cromato in ABS.

*With chrome-plated ABS shower holder.*

*Avec support chrome en ABS.*

■ CR



Miscelatore PRIMA PLUS incasso con supporto in ottone e piastra quadra 110 mm, doccia igienica a pulsante NAMIR quadra in ottone, flessibile SILVER 1200 mm.

✓ SH 822

*PRIMA PLUS built-in mixer with brass shower holder and square plate 110 mm, NAMIR brass square hygienic shower with trigger, SILVER flexible hose 1200 mm.*

*Mitigeur PRIMA PLUS encastré avec support en laiton et plaque carrée 110 mm, douchette hygiénique carrée à levier NAMIR en laiton, flexible SILVER 1200 mm.*

VARIANTI / Variations / Variantes

■ ORO / BS / RS / NS / CR / NEO / BIO



✓ SH 822 ABS

Con supporto cromato in ABS.

*With chrome-plated ABS shower holder.*

*Avec support chrome en ABS.*

■ CR

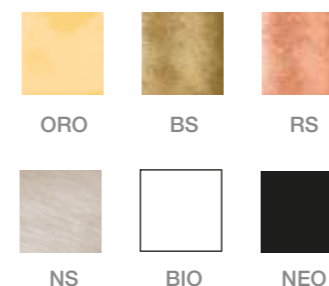

ORO - Oro/Gold/Or BS - Bronzo spazzolato/Brushed brass/Laiton brossé

RS - Rame spazzolato/Brushed copper/Cuivre brossé

NS - Nickel spazzolato/Brushed nickel/Nickel brossé

BIO - Bianco opaco/Matte white/Blanche mate

NEO - Nero opaco/Matte black/Noire mate CR - Cromo/Chrome

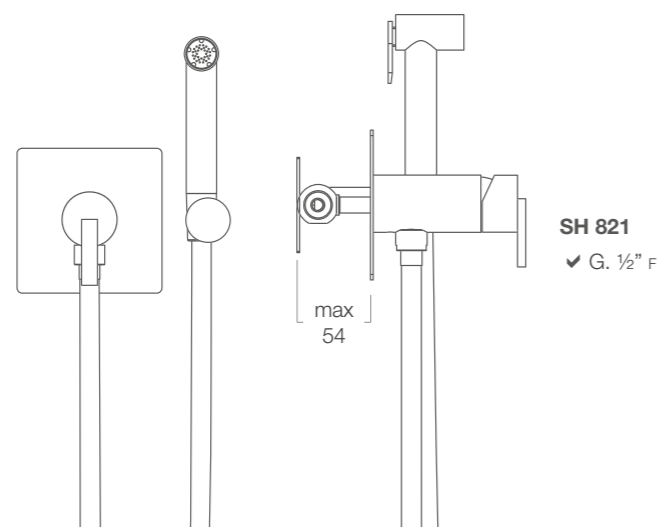

SH 821

✓ G. 1/2" F

max  
54

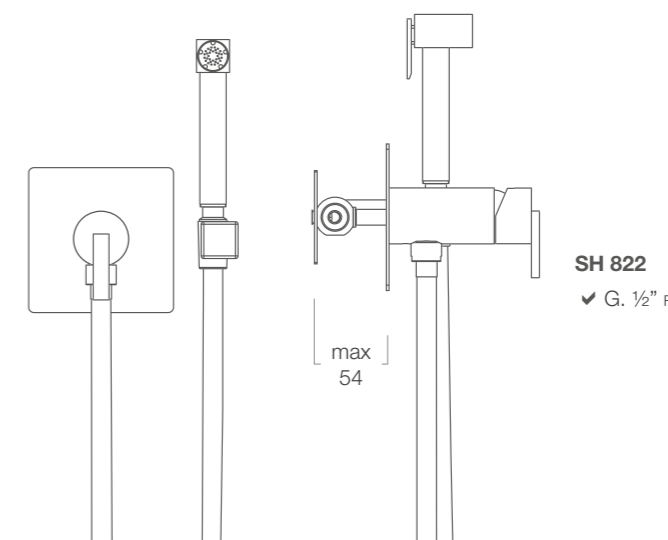

SH 822

✓ G. 1/2" F

max  
54

Miscelatore MINIMALISTA con supporto, interasse 150 mm, doccia igienica a pulsante AIDA tonda in ottone, flessibile SILVER 1200 mm.

✓ SH 603

MINIMALISTA mixer with shower holder, center to center distance 150 mm, AIDA brass round hygienic shower with push button, SILVER flexible hose 1200 mm.

Mitigeur MINIMALISTA avec support, entraxe 150 mm, douche hygiénique ronde à poussoir AIDA en laiton, flexible SILVER 1200 mm.

VARIANTI / Variations / Variantes

■ ORO / BS / RS / NS / CR / NEO / BIO



Miscelatore MINIMALISTA con supporto, interasse 100 mm, doccia igienica a pulsante AIDA tonda in ottone, flessibile SILVER 1200 mm.

✓ SH 613

MINIMALISTA mixer with shower holder, center to center distance 100 mm, AIDA brass round hygienic shower with push button, SILVER flexible hose 1200 mm.

Mitigeur MINIMALISTA avec support, entraxe 100 mm, douche hygiénique ronde à poussoir AIDA en laiton, flexible SILVER 1200 mm.

VARIANTI / Variations / Variantes

■ ORO / BS / RS / NS / CR / NEO / BIO

✓ SH 601

Con doccia igienica STELLA (p. 148).

With STELLA hygienic shower.

Avec douche hygiénique STELLA.

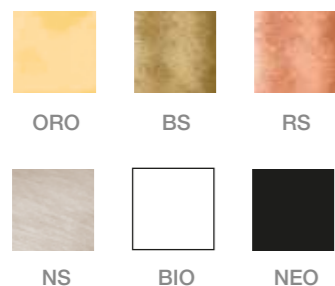

ORO - Oro/Gold/Or BS - Bronzo spazzolato/Brushed brass/Laiton brossé  
RS - Rame spazzolato/Brushed copper/Cuivre brossé  
NS - Nickel spazzolato/Brushed nickel/Nickel brossé  
BIO - Bianco opaco/Matte white/Blanche mate  
NEO - Nero opaco/Matte black/Noire mate CR - Cromo/Chrome

✓ SH 611

Con doccia igienica STELLA (p. 148).

With STELLA hygienic shower.

Avec douche hygiénique STELLA.

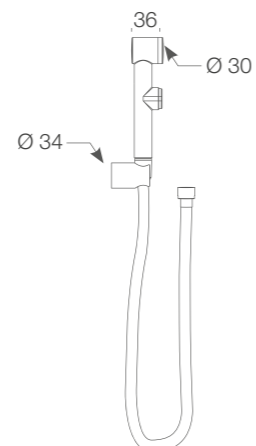
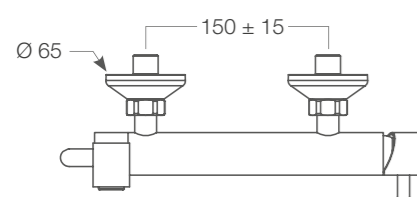

SH 603 / SH 601

SH 613 / SH 611

✓ L 266 mm

✓ G. 1/2" M





# Iperscopini



Iperscopino tondo a pulsante STELLA in ottone, supporto in ABS, flessibile SILVER 1200 mm.

✓ IP 701

STELLA brass round hydro brush with trigger, ABS shower holder, SILVER flexible hose 1200 mm.

Douchette hydrobrosse ronde à levier STELLA en laiton, support en ABS, flexible SILVER 1200 mm.

VARIANTI / Variations / Variantes

■ ORO / BS / RS / NS / CR / NEO / BIO

Iperscopino quadro a pulsante NAMIR in ottone, supporto in ABS, flessibile SILVER 1200 mm.

✓ IP 702

NAMIR brass square hydro brush with trigger, ABS shower holder, SILVER flexible hose 1200 mm.

Douchette hydrobrosse carrée à levier NAMIR en laiton, support en ABS, flexible SILVER 1200 mm.

VARIANTI / Variations / Variantes

■ ORO / BS / RS / NS / CR / NEO / BIO



ORO BS RS NS BIO NEO

ORO - Oro/Gold/Or BS - Bronzo spazzolato/Brushed brass/Laiton brossé RS - Rame spazzolato/Brushed copper/Cuivre brossé NS - Nickel spazzolato/Brushed nickel/Nickel brossé BIO - Bianco opaco/Matte white/Blanche mate NEO - Nero opaco/Matte black/Noire mate CR - Cromo/Chrome

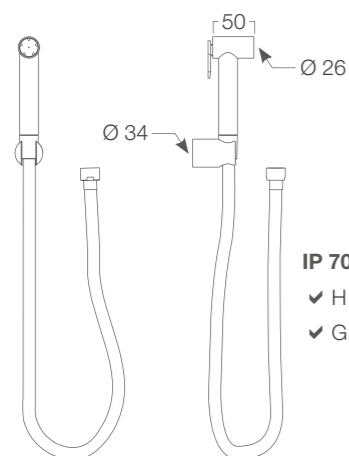

IP 701  
✓ H 128 mm  
✓ G. 1/2" F

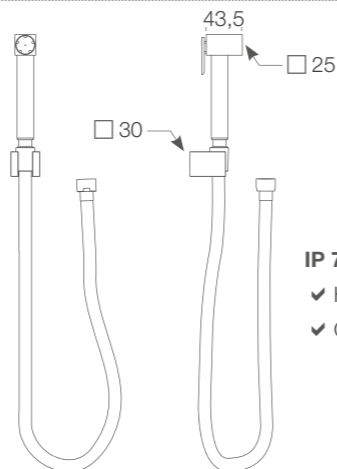

IP 702  
✓ H 143,5 mm  
✓ G. 1/2" F



Preso acqua con supporto tondo e valvola di sicurezza, iperscopino tondo a pulsante STELLA in ottone, flessibile SILVER 1200 mm.

✓ IP 801

Water intake with round shower holder with safety valve, STELLA brass round hydro brush with trigger, SILVER flexible hose 1200 mm.

Prise d'eau avec support rond avec valve de sécurité, douchette hydrobrosse ronde à levier STELLA en laiton, flexible SILVER 1200 mm



VARIANTI / Variations / Variantes

■ ORO / BS / RS / NS / CR / NEO / BIO



Preso acqua con supporto quadro e valvola di sicurezza, iperscopino quadro a pulsante NAMIR in ottone, flessibile SILVER 1200 mm.

✓ IP 802

Water intake with square shower holder with safety valve, NAMIR brass square hydro brush with trigger, SILVER flexible hose 1200 mm.

Prise d'eau avec support carré valve de sécurité, douchette hydrobrosse carrée à levier NAMIR en laiton, flexible SILVER 1200 mm.



VARIANTI / Variations / Variantes

■ ORO / BS / RS / NS / CR / NEO / BIO

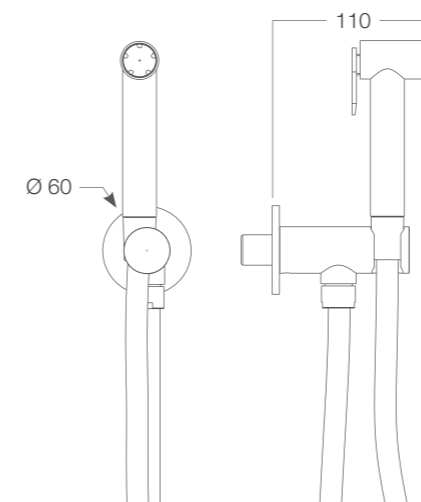

IP 801  
✓ G. 1/2" M

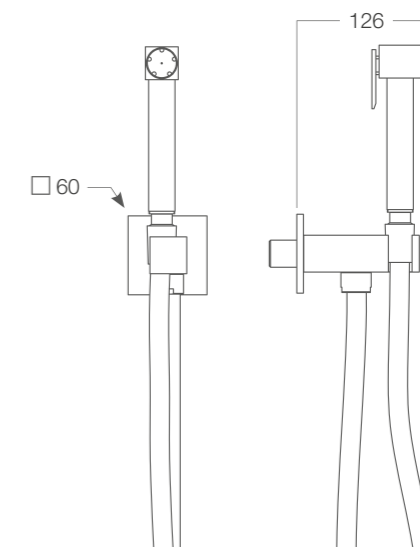

IP 802  
✓ G. 1/2" M



Presacqua PADLOCK con supporto tondo e comando di sicurezza, iperscopino a pulsante STELLA in ottone, flessibile ULTRAFLEX 1200 mm.

✓ KSPAT100-07-01

*PADLOCK water inlet with round security holder, STELLA brass hydro brush with trigger, ULTRAFLEX flexible hose 1200 mm.*

*Prise d'eau PADLOCK avec support rond et déclencheur de sécurité, hydrobrosse STELLA en laiton avec poussoir, flexible ULTRAFLEX 1200 mm.*

VARIANTI / Variations / Variantes

■ ORO / BS / RS / NS / CR / NEO / BIO

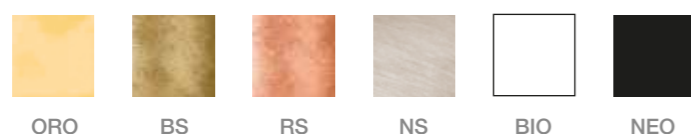

ORO - Oro/Gold/Or BS - Bronzo spazzolato/Brushed brass/Laiton brossé RS - Rame spazzolato/Brushed copper/Cuivre brossé NS - Nickel spazzolato/Brushed nickel/Nickel brossé BIO - Bianco opaco/Matte white/Blanche mate NEO - Nero opaco/Matte black/Noire mate CR - Cromo/Chrome

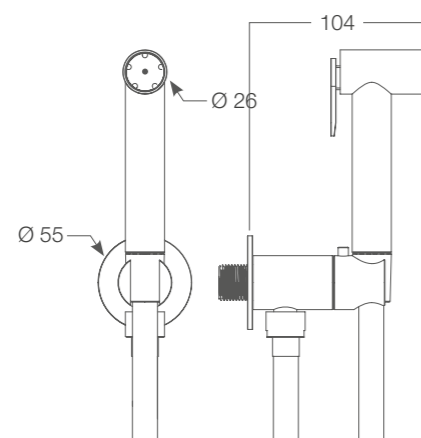

**KSPAT100-07-01**

✓ H 128 mm  
✓ G. 1/2"



Presacqua PADLOCK con supporto quadro e comando di sicurezza, iperscopino a pulsante NAMIR in ottone, flessibile ULTRAFLEX 1200 mm.

✓ KSPAQ100-09-01

*PADLOCK water inlet with square security holder, NAMIR brass hydro brush with trigger, ULTRAFLEX flexible hose 1200 mm*

*Prise d'eau PADLOCK avec support carré et déclencheur de sécurité, hydrobrosse NAMIR en laiton avec poussoir, flexible ULTRAFLEX 1200 mm.*

VARIANTI / Variations / Variantes

■ ORO / BS / RS / NS / CR / NEO / BIO

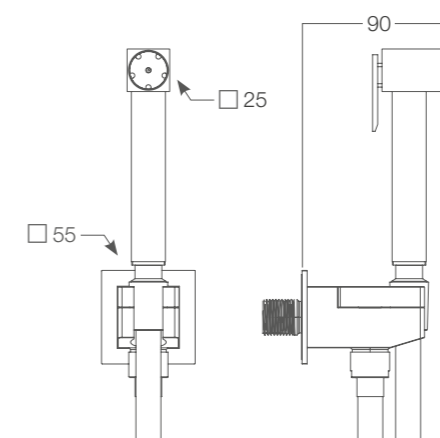

**KSPAQ100-09-01**

✓ H 143,5 mm  
✓ G. 1/2"

Tecnologia al servizio del design. La serie HOOK utilizza la tecnologia per estremizzare il minimalismo. Il rubinetto ridotto alla sola bocca erogatrice, il funzionamento al semplice tocco. Il miscelatore HOOK garantisce confort e rispetto per l'ambiente. Temperatura e tempo di erogazione possono essere impostati a piacere; la portata dell'acqua è limitata. Ecologia che rispetta le nostre comodità.

*Technology for design. The HOOK series utilises technological ability to express minimalism. A tap reduced to its spout, functioning with just one touch. The mixer tap HOOK guarantees comfort and respect for the environment. Temperature and "dispense time" can be programmed accordingly; the flow of water is limited. Ecology which respects our own convenience.*

*La technologie au service du design. La série HOOK utilise la technologie capacitive et pousse le minimalisme à son extrême. Réduit à son simple bec d'écoulement, le robinet HOOK fonctionne par simple touché. Le mitigeur HOOK assure le confort et respecte l'environnement. La température et le temps d'écoulement peuvent être prédisposés au grès de l'utilisateur; le débit de l'eau est limité. L'écologie répond à nos désirs de confort.*

# Hook

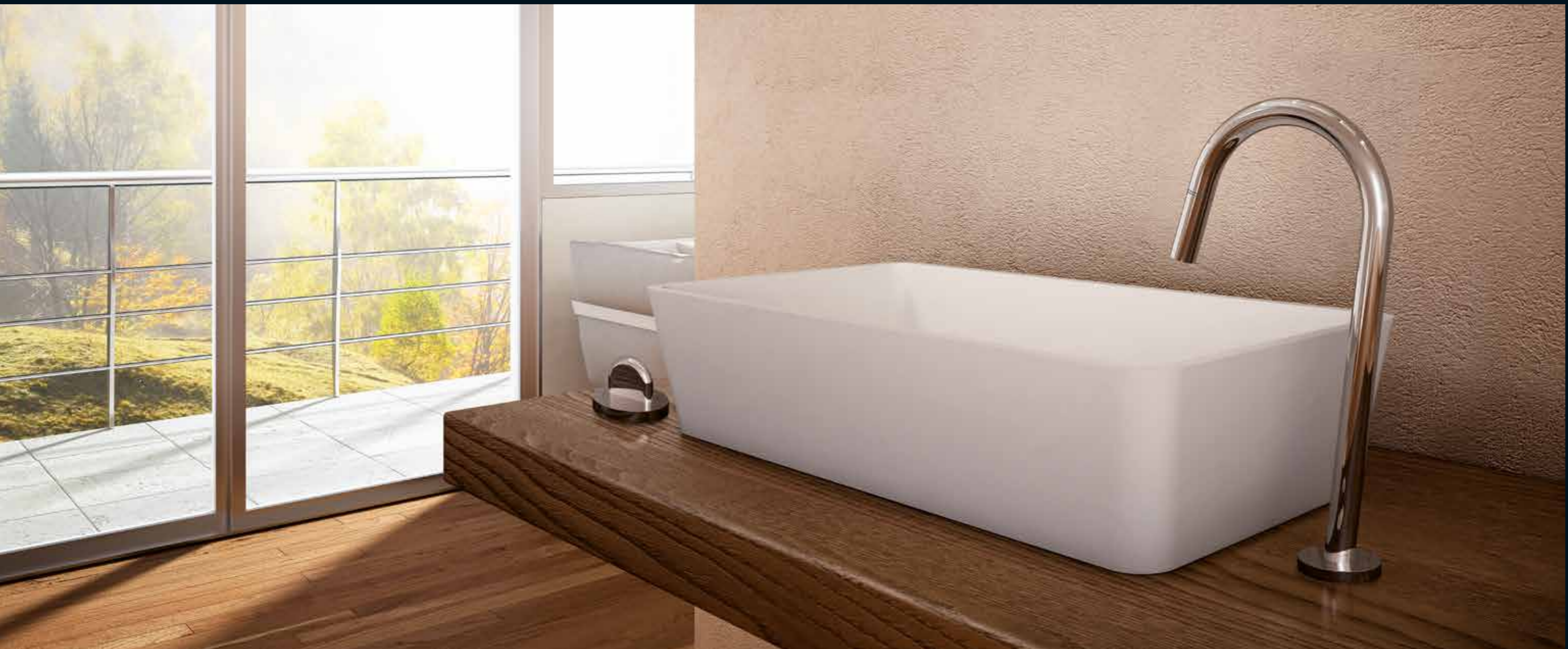

Miscelatore lavabo termostatico alto HOOK,  
2 fori, "touch".

✓ HO 001

HOOK thermostatic washbasin mixer,  
high spout, 2 holes, "touch".

Mitigeur lavabo thermostatique haut HOOK,  
2 trous, "touch".



VARIANTI / Variations / Variantes

■ CR

Miscelatore lavabo alto HOOK,  
2 fori, cartuccia ceramica, "touch".

✓ HO 101

HOOK high spout washbasin mixer,  
2 holes, ceramic cartridge, "touch".

Mitigeur lavabo haut HOOK,  
2 trous, cartouche céramique, "touch".



VARIANTI / Variations / Variantes

■ CR



Miscelatore lavabo termostatico alto HOOK,  
su piastra, "touch".

✓ HO 002

HOOK thermostatic washbasin mixer,  
high spout, deck mounted, "touch".

Mitigeur lavabo thermostatique haut HOOK,  
sur plaque, "touch".



VARIANTI / Variations / Variantes

■ CR

Miscelatore lavabo alto HOOK,  
su piastra, cartuccia ceramica, "touch".

✓ HO 102

HOOK high spout washbasin mixer,  
deck mounted, ceramic cartridge, "touch".

Mitigeur lavabo haut HOOK, sur plaque,  
cartouche céramique, "touch".



VARIANTI / Variations / Variantes

■ CR



SENZA SCARICO/Without waste/Sans vidage.

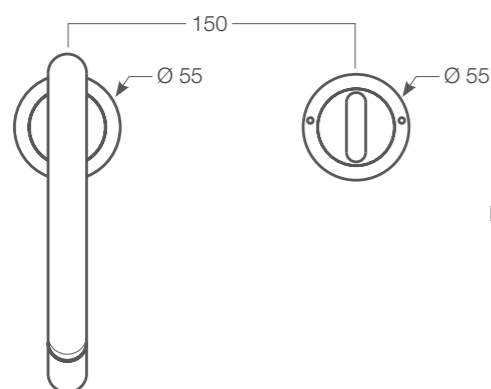

HO 001 / HO 101

- ✓ Ø 20 mm
- ✓ H 321 mm
- ✓ / 7°

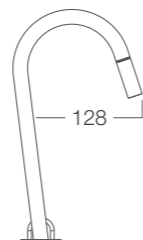

SENZA SCARICO/Without waste/Sans vidage.

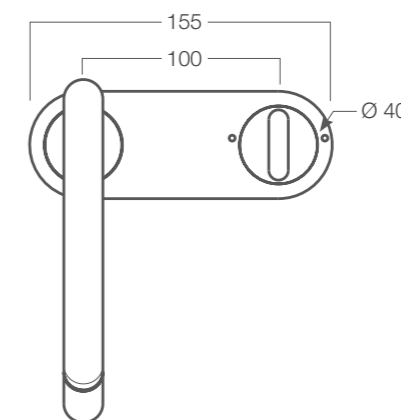

HO 002 / HO 102

- ✓ Ø 20 mm
- ✓ H 321 mm
- ✓ / 7°

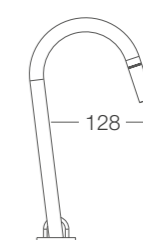

Miscelatore lavabo termostatico HOOK,  
2 fori, "touch".

✓ HO 003

HOOK thermostatic washbasin mixer,  
2 holes, "touch".

Mitigeur lavabo thermostatique HOOK  
2 trous, "touch".



VARIANTI / Variations / Variantes

■ CR

Miscelatore lavabo HOOK,  
2 fori, cartuccia ceramica, "touch".

✓ HO 103

HOOK washbasin mixer, 2 holes,  
ceramic cartridge, "touch".

Mitigeur lavabo HOOK, 2 trous,  
cartouche céramique, "touch".



VARIANTI / Variations / Variantes

■ CR



Miscelatore lavabo termostatico HOOK,  
su piastra, "touch".

✓ HO 004

HOOK thermostatic washbasin mixer,  
deck mounted, "touch".

Mitigeur lavabo thermostatique HOOK,  
sur plaque, "touch".



VARIANTI / Variations / Variantes

■ CR

Miscelatore lavabo HOOK, su piastra,  
cartuccia ceramica, "touch".

✓ HO 104

HOOK washbasin mixer, deck mounted,  
ceramic cartridge, "touch".

Mitigeur lavabo HOOK, sur plaque,  
cartouche céramique, "touch".



VARIANTI / Variations / Variantes

■ CR



SENZA SCARICO/Without waste/Sans vidage.

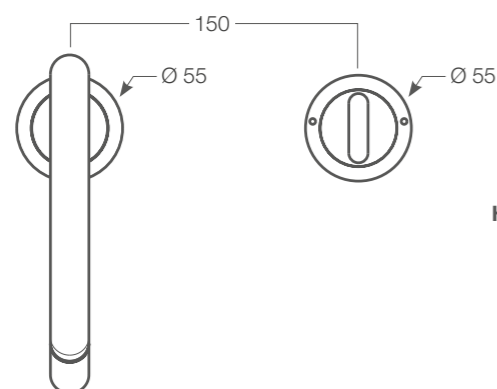

HO 003 / HO 103

- ✓ Ø 20 mm
- ✓ H 241 mm
- ✓ / 7°

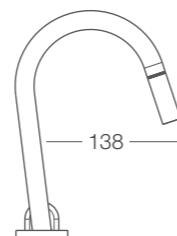

SENZA SCARICO/Without waste/Sans vidage.

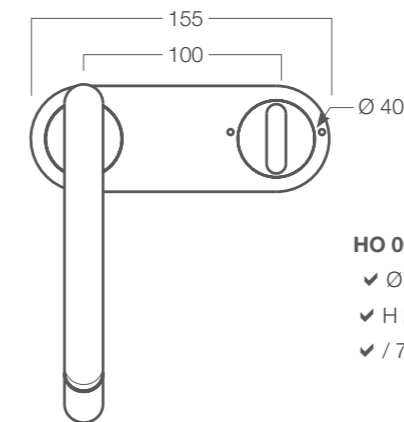

HO 004 / HO 104

- ✓ Ø 20 mm
- ✓ H 241 mm
- ✓ / 7°

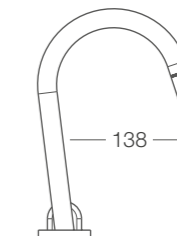

# Indice alfabetico dei codici

Codes' alphabetical index / Index alphabétique des codes.

AM 001 .....p. 120	FR 003 .....p. 45	KSPAT100-07.....p. 150	SK 016 .....p. 56
AM 001-PA.....p. 120	FR 004 .....p. 44	KSPAT100-07-01 .....p. 162	SK 201 .....p. 60
AM 010 M .....p. 116	FR 011 .....p. 43	KSPAT101-07.....p. 151	SK 221 .....p. 60
AM 020 M .....p. 117	FR 012 .....p. 45	KU 001.....p. 112	SK 231 .....p. 85
AM 020 T .....p. 117	FR 401 .....p. 44		SK 271 .....p. 86
AM 030 M .....p. 118	FR 801 .....p. 43	LA 001 .....p. 34	SK 404 .....p. 61
AM 030 T .....p. 118		LA 401 .....p. 37	SK 414 .....p. 59
AM 040 T .....p. 119	GA 001.....p. 109	LA 801 .....p. 35	SK 416 .....p. 59
AM 401 .....p. 121	GI 001 .....p. 113	LA 802 .....p. 36	SK 804.....p. 57
AM 401-PA.....p. 121	GY 002.....p. 74	LA 803 .....p. 35	SK 814 .....p. 57
AM 410 M .....p. 116	GY 003.....p. 74	LA 804 .....p. 36	SK 844 .....p. 61
AM 420 M .....p. 117	GY 005.....p. 74	LA 920 .....p. 38	SK 854 .....p. 61
AM 420 T .....p. 117	GY 077.....p. 82	LA 975 .....p. 38	ST 001 .....p. 97
AM 430 M .....p. 118	GY 271.....p. 82	LM 100.....p. 133	ST 002 .....p. 97
AM 430 T .....p. 118	GY 402.....p. 75	LM 190.....p. 135	ST 003 .....p. 97
AM 440 T .....p. 119	GY 403.....p. 75	LM 800.....p. 133	ST 201 .....p. 96
AR 004.....p. 50	GY 405.....p. 75		ST 202 .....p. 96
AR 014.....p. 49	GY 477.....p. 83	ME 190 .....p. 128	ST 203 .....p. 96
AR 016.....p. 49	GY 802.....p. 70	MQ 190.....p. 128	
AR 201 .....p. 52	GY 803.....p. 70	MR 002 .....p. 66	TA 001.....p. 106
AR 221 .....p. 52	GY 805.....p. 70	MR 003 .....p. 66	TA 002.....p. 107
AR 231 .....p. 85	GY 812.....p. 72	MR 402 .....p. 66	TA 401.....p. 104
AR 271 .....p. 86	GY 813.....p. 72	MR 403 .....p. 66	TA 402.....p. 105
AR 404.....p. 53	GY 815.....p. 72	MR 802 .....p. 64	TA 801.....p. 106
AR 414.....p. 51	GY 842.....p. 71	MR 803 .....p. 64	TA 802.....p. 107
AR 416.....p. 51	GY 843.....p. 71	MR 812 .....p. 65	TA 811.....p. 106
AR 804.....p. 50	GY 845.....p. 71	MR 813 .....p. 65	TA 812.....p. 107
AR 814.....p. 50	GY 852.....p. 73	MR 842 .....p. 64	TA 841.....p. 104
AR 844.....p. 53	GY 853.....p. 73	MR 843 .....p. 64	TA 842.....p. 105
AR 854.....p. 53	GY 855.....p. 73	MR 852 .....p. 65	TA 851.....p. 104
		MR 853 .....p. 65	TA 852.....p. 105
			TEQ 003.....p. 144
BJ 011 .....p. 139	HO 001 .....p. 166		TEQ 007 .....p. 144
BJ 012 .....p. 140	HO 002 .....p. 167	NW 001.....p. 112	TEQ 021 .....p. 145
BJ 021 .....p. 138	HO 003 .....p. 168		TEQ 023 .....p. 145
BJ 311 .....p. 139	HO 004 .....p. 169	OW 001.....p. 79	TET 003 .....p. 144
BJ 312 .....p. 140	HO 101 .....p. 166	OW 002.....p. 79	TET 003 .....p. 144
BJ 321 .....p. 138	HO 102 .....p. 167	OW 801.....p. 78	TET 007 - 01 .....p. 144
BJ 411 .....p. 139	HO 103 .....p. 168	OW 802.....p. 78	TET 023 .....p. 145
BJ 412 .....p. 140	HO 104 .....p. 169		TU 001 .....p. 16
BJ 421 .....p. 138			TU 002 .....p. 16
	IP 701 .....p. 160		TU 003 .....p. 15
CA 100.....p. 124	IP 702 .....p. 160		TU 004 .....p. 15
CA 101 .....p. 126	IP 801 .....p. 161		TU 005 .....p. 15
CD 100.....p. 126	IP 802 .....p. 161		TU 006 .....p. 16
CD 101.....p. 127			TU 007 .....p. 16
CD 101-01 .....p. 127	KI 011 .....p. 91	RE 100.....p. 132	TU 010 .....p. 17
CI 001 .....p. 30	KI 012 .....p. 91	RE 190.....p. 135	TU 020 .....p. 17
CI 002 .....p. 30	KI 014 .....p. 91	RE 800.....p. 134	TU 030 .....p. 17
CI 003 .....p. 30	KI 201 .....p. 90		TU 040 .....p. 18
CI 801 .....p. 28	KI 221 .....p. 90	SH 601.....p. 156	TU 041 .....p. 18
CI 802 .....p. 28	KI 231 .....p. 85	SH 603.....p. 156	TU 050 .....p. 19
CI 803 .....p. 28	KI 251 .....p. 90	SH 611.....p. 156	TU 090 .....p. 20
CI 804 .....p. 29	KI 261 .....p. 90	SH 613.....p. 156	TU 091 .....p. 20
CI 805 .....p. 29	KI 270Q.....p. 84	SH 701.....p. 148	TU 100 .....p. 21
CI 806 .....p. 29	KI 270T .....p. 84	SH 702.....p. 148	TU 120 .....p. 24
CI 900 .....p. 31	KI 271 .....p. 86	SH 703.....p. 148	TU 180 .....p. 23
CR 001.....p. 100	KI 411 .....p. 92	SH 801.....p. 149	TU 180-00.....p. 23
CR 002.....p. 101	KI 412 .....p. 92	SH 802.....p. 149	TU 190 .....p. 22
CT 100.....p. 124	KI 414 .....p. 92	SH 811.....p. 152	TU 800 .....p. 20
CT 101 .....p. 125	KI 477 .....p. 83	SH 812.....p. 153	TU 801 .....p. 19
CT 101-01.....p. 125	KI 477 .....p. 83	SH 821.....p. 154	TU 906.....p. 19
	KI 570Q.....p. 84	SH 821 ABS.....p. 154	
	KI 570T .....p. 84	SH 822.....p. 155	
DW 001 .....p. 110	KI 570T .....p. 84	SH 822 ABS.....p. 155	
	KSPAQ100-09-01 .....p. 163	SK 004.....p. 57	
	KSPAQ101-09.....p. 151	SK 014.....p. 56	
	KSPAQ100-9.....p. 150		

## Condizioni generali di vendita

Le presenti condizioni generali disciplinano tutti gli attuali e futuri contratti fra le parti, salvo eventuali deroghe specificatamente concordate per iscritto. Eventuali condizioni generali del compratore non troveranno applicazione nei rapporti futuri tra le parti se non espressamente accettate per iscritto dalla ditta Nuova Osmo.

### 1. Formazione del contratto

L'invio da parte del compratore di un ordine al venditore comporta l'applicazione al contratto di vendita delle presenti condizioni generali. Il venditore si riserva il diritto di accettare o rifiutare l'ordine ricevuto. Le offerte fatte da agenti, rappresentanti ed ausiliari di commercio del venditore non sono per lui impegnative fino a quando non siano confermate dal venditore stesso.

### 2. Prezzi

Ai prezzi indicati nel presente listino deve essere applicata l' I.V.A. secondo l'aliquota in vigore al momento della fatturazione. Il venditore si riserva di modificare i prezzi, o variare il listino prezzi senza alcun preavviso.

### 3. Resa della Merce

Salvo patto contrario, la fornitura dei prodotti si intende Franco Fabbrica del venditore: trasporto ed assicurazione sono pertanto a carico del compratore e ciò anche quando sia convenuto che la spedizione o parte di essa venga curata dal venditore, nel qual caso quest' ultimo agirà come mandatario del compratore, essendo inteso che il trasporto verrà effettuato a rischio del compratore. I rischi relativi alla fornitura passano al compratore al momento in cui i prodotti lasciano lo stabilimento del venditore.

### 4. Termini di consegna

I termini di consegna si intendono approssimativi a favore del venditore e comunque con un congruo margine di tolleranza. È esclusa qualsiasi responsabilità del venditore per danni derivanti da anticipata, ritardata o mancata consegna, totale o parziale. Il compratore è sempre tenuto a prendere in consegna i prodotti, anche in caso di consegne parziali e quando i prodotti vengano consegnati prima o successivamente alla data di consegna stabilita. Il termine di consegna verrà prorogato di un periodo pari a quello della durata dell'impedimento al verificarsi di cause di forza maggiore. In nessun caso, a causa del verificarsi di tali circostanze, il compratore potrà esigere compensi o indennizzi di qualsiasi natura.

### 5. Garanzia

Il venditore garantisce la conformità dei prodotti forniti; con il termine di conformità dei prodotti si intende che essi corrispondono per qualità, quantità e tipo a quanto stabilito nel contratto e che sono esenti da vizi che potrebbero renderli non idonei all'uso cui sono destinati. La garanzia per vizi è limitata ai soli difetti dei prodotti conseguenti a difetti di progettazione, di materiale o di costruzione riconducibili al venditore e non si applica nel caso in cui il compratore non provi di aver effettuato una corretta conservazione dei prodotti e di non averli modificati senza il consenso del venditore. Il venditore non risponde dei difetti di conformità dei prodotti dovuti all'usura normale di quelle parti che, per loro natura sono soggette a usura rapida e continua.

### 6. Reclami

Il compratore è tenuto a verificare la conformità dei prodotti e l'assenza di vizi. I reclami relativi a non conformità dei prodotti forniti dovranno essere effettuati, a pena di decadenza, entro e non oltre quindici giorni dal ricevimento della merce a destino. I vizi, difetti o non conformità occulti devono essere denunciati immediatamente alla loro scoperta e comunque, a pena di decadenza, entro e non oltre sei mesi dalla data di consegna. Tutti i reclami devono essere effettuati mediante lettera raccomandata indirizzata al venditore e devono indicare dettagliatamente i vizi e le non conformità contestate. La garanzia ha una durata di sei mesi.

### 7. Rimedi

In caso di prodotti non conformi, e dopo aver ricevuto un rapporto dettagliato dal compratore, il venditore potrà, a sua insindacabile scelta:

- fornire gratuitamente Franco Fabbrica al compratore prodotti dello stesso genere e quantità di quelli risultanti difettosi o non conformi a quanto pattuito, dopo averne ottenuto la resa per la verifica. L'eventuale sostituzione effettuata prontamente dal venditore non può essere ritenuta un implicito riconoscimento dei vizi contestati: detto riconoscimento dovrà essere sempre esplicito e conseguente al controllo del venditore sui prodotti contestati. Qualora il venditore, in sede di verifica, non riconosca viziati i prodotti, provvederà alla fatturazione di quelli inviati in sostituzione.
- emettere una nota di accredito a favore del compratore per un importo corrispondente al valore dei prodotti difettosi.

In entrambi i casi il venditore ha diritto alla restituzione dei prodotti difettosi, che diventano di sua proprietà.

### 8. Limitazione di responsabilità del venditore

Salvo dolo o colpa grave del venditore, l'eventuale risarcimento di qualsiasi danno al compratore non potrà comunque superare il prezzo di fattura dei prodotti contestati.

### 9. Pagamento

I pagamenti ed ogni altra somma dovuta a qualsiasi titolo al venditore si intendono netti al suo domicilio. Qualsiasi ritardo o irregolarità nel pagamento dà al venditore il diritto di sospendere le forniture o di risolvere contratti in corso, anche non relativi ai pagamenti in questione, nonché il diritto al risarcimento degli eventuali danni. Il venditore ha altresì il diritto a decorrere dalla scadenza del pagamento, agli interessi moratori nella misura stabilita in Italia dall'articolo 5 del Decreto Legislativo 9 Ottobre 2002, n° 231. Il ritardo nei pagamenti dà altresì al venditore il diritto di escludere la garanzia per tutto il periodo durante il quale il ritardo perdura.

### 10. Riserva di proprietà

I prodotti consegnati restano di proprietà del venditore sino al momento del completo pagamento del prezzo.

### 11. Legge applicabile e foro competente

Tutti i contratti disciplinati dalle presenti condizioni generali sono regolati dalla legge italiana.

Per ogni controversia relativa o comunque collegata ai contratti cui si applicano le presenti condizioni generali è esclusivamente competente il foro del venditore: quest'ultimo avrà tuttavia facoltà di agire presso il foro del compratore.

## General conditions for sale

These general conditions regulate all present and future sales contracts between the parties, subject to any exceptions specifically agreed upon in writing. Any general conditions of the purchaser will not apply to future contractual relations between the parties unless expressly accepted in writing by Nuova Osmo.

### 1. Formation of the Contract

The purchaser placing the order fully accepts the application of these general terms to the contract for sale. Seller reserves the right to accept or refuse it. Offers made by Agents, Representatives or auxiliaries of the seller do not bind him until they are confirmed by the seller itself.

### 2. Prices

The prices indicated in this price list do not include V.A.T. or any other tax whatsoever. Seller may modify the prices / price list without prior notice.

### 3. Surrender of the goods

Unless agreed to the contrary, the supply of the products is intended ex-factory: transport and insurance are therefore at the charge of the purchaser, this also when it is decided that the delivery or part of it will be taken care of by the seller, in which case the latter will act as the purchaser's agent, it being understood that the transport will be carried out at the expense and risk of the purchaser. The risk relative to the supply pass to the purchaser, at the latest at the time in which the products leave the seller's plant.

### 4. Delivery terms

The delivery limits are agreed approximately in favour of the seller and not binding for him. Any liability of the seller is excluded for damage deriving from anticipated, delayed or non delivery, total or partial.

The purchaser is always held to take delivery of the products, even in the case of partial deliveries and even when the products are consigned before the established delivery date of successively to that date.

The seller shall not be deemed to be in breach of this agreement, or otherwise be liable to the purchaser, by reason of any delay in delivery, to the extent that the delay is due to any Force Major, and the time for performance of delivery shall be extended accordingly.

### 5. Guarantee

The seller guarantees the compliance of the products supplied; by the term compliance of the products it is meant that they correspond in quality, quantity and type to what was agreed in the contract and that they are without defects that could render them unfit for the use to which they are intended to be put. The guarantee against defects is limited only to product defects due to defects in planning, materials or construction that can be attributed to the seller, and does not apply in the case where the purchaser is unable to prove a correct preservation of the product and where he has modified them without the agreement of the seller. The seller is not liable for defects in product compliance due to the normal wear of those parts which, by nature, are subject to rapid and continuous wear and tear.

### 6. Claims

The purchaser is required to control the compliance of the products and the absence of flaws.

Claims relevant to non-conformities of the goods must be made, on pain of forfeiture, within and not later than fifteen days from the goods arrival at their place of destination.

Hidden flaws, defect or non-compliances must be reported immediately after the discovery and in any event, on pain of forfeiture, not later than six months from the delivery date.

Claims must be made by registered letter, addressed to the seller and must describe in detail the flaws or disputed non-compliances. The guarantee is for a limited period of six months from delivery date.

### 7. Remedies

In case of faulty products and following to a report by the purchaser, the seller may at his discretion:

- supply ex-factory to the purchaser products of the same kind and quantity as those that proved not in compliance, on receiving returns for checking. Any replacement carried out promptly by the seller cannot be considered as implicit recognition of defects claimed: said recognition must always be explicit and following control by seller on goods challenged: should the seller, on controlling, find the goods in compliance, he will invoice for those sent in replacement;
- issue to the purchaser a credit-note in the amount equal to the value of the defective products.

In both cases the purchaser shall return the faulty products to the seller.

### 8. Limit of the seller's liability

Except in the case of fraud or gross negligence on the seller's part, compensation of any damage to the purchaser will not, in any event, be greater than invoice price of the disputed products.

### 9. Payments

The payment and every other sum due to the seller, are understood as net at the registered office of the seller.

Any delay or irregularity in the payment gives the seller the right to suspend the supply or to cancel the contract in course, even if they are not relevant to the payment in question, as well as the right to the compensation for eventual damages. The seller has also the right – starting from the payment deadline – to interests for delay as per art. 5 of Italian Legislative Decree no. 231 of 09/10/2002. The delays of payment likewise give the seller the right to exclusion from guarantee, for the whole period that the delay may persist.

### 10. Retention of Title

The delivered products remain the seller's property until the moment of the complete payment of the price.

### 11. Applicable Law and Competent Law-Court

All contracts ruled by these general conditions are submitted to Italian Law. For any controversy relative to, connected to the contractual products to which these general conditions apply, the seller's Law-Court has the exclusive competence: the latter, however, will have the opportunity to act also in the purchaser's Law-Court.

## Conditions générales de vente

Les présentes conditions générales disciplinent tous les contrats actuels et futurs entre les parties, sous réserve des exceptions convenues par écrit. Toutes les éventuelles conditions générales de l'acheteur ne trouveront pas d'application dans les relations futures entre les parties si non expressément acceptées par écrit par la société Nuova Osmo.

### 1. Formation du contrat

L'envoi par l'acheteur au vendeur d'une commande entraîne l'application au contrat de vente des présentes conditions générales. Le vendeur se réserve le droit d'accepter ou de refuser l'ordre reçu. Les offres faites par les agents, représentants et intermédiaires commerciaux du vendeur ne contraignent le vendeur que dès lors qu'elles sont confirmées par le vendeur lui-même.

### 2. Prix

Aux prix indiqués dans cette liste de prix doit être appliquée l'I.V.A au taux en vigueur au moment de la facturation. Le vendeur se réserve le droit de modifier les prix, ou de modifier la liste de prix sans aucun préavis.

### 3. Marchandise rendue

Sauf si contrairement convenu, la fourniture des produits s'entend départ usine du vendeur: transport et assurance sont pour autant à la charge de l'acheteur et ceci même lorsqu'il est convenu que l'expédition du lot ou d'une partie de celui-ci est préparée par le vendeur, dans ce cas, ce dernier agira comme représentant de l'acheteur, entendu que le transport sera effectué au risque de l'acheteur. Les risques relatifs à la fourniture passent à l'acheteur dès que la marchandise quitte l'usine du vendeur.

### 4. Termes de livraison

Les délais de livraison s'entendent approximatifs en faveur du vendeur et en tout cas avec une marge de tolérance raisonnable. Toute responsabilité du vendeur est exclue pour dommages dérivant de livraison anticipée, retardée ou manquée de façon totale ou partielle. L'acheteur est toujours tenu à prendre les produits livrés, même en cas de livraisons partielles et lorsque les marchandises sont livrées avant ou après la date de livraison prévue. La date de livraison sera prolongée d'une période égale à la durée de l'empêchement à l'apparition de causes de force majeure. En aucun cas, à cause de survenance de telles circonstances, l'acheteur ne pourra prétendre à indemnisation ou remboursement de quelque nature.

### 5. Garantie

Le vendeur garantit la conformité des produits fournis; avec le terme conformité des produits il est entendu que ces produits correspondent en qualité, quantité et type à ce qui est établi dans le contrat et qu'ils sont exempts de défauts qui pourraient les rendre impropres à l'usage auquel ils sont destinés.

La garantie pour les défauts est limitée aux défauts des produits résultants de défauts de conception, de matériaux ou de fabrication imputables au vendeur, et n'est pas applicable dans le cas où l'acheteur ne prouve pas qu'il a correctement conservés les produits et qu'il ne les a pas modifiés sans le consentement du vendeur. Le vendeur ne répond pas des défauts de conformité des produits qui sont dus à l'usure normale des pièces qui, de par leur nature, sont soumises à une usure rapide et continue.

### 6. Plaintes

L'acheteur est tenu de vérifier la conformité des produits et l'absence de vices. Les plaintes relatives à non-conformité des produits fournis doivent être faites, sous peine de déchéance, au plus tard dans les quinze jours qui suivent de la réception à destination des marchandises. Les vices, défauts ou de non-conformité cachés doivent être signalés immédiatement à leur découverte et, en tout cas, sous peine de déchéance, au plus tard dans les six mois à compter de la date de livraison. Toutes les plaintes doivent être faites par lettre recommandée adressée au vendeur et doivent indiquer de façon détaillée les vices et les non-conformités contestés. La garantie a une durée de six mois.

### 7. Recours

En cas de produits non conformes, et après avoir reçu un rapport détaillé de l'acheteur, le vendeur peut, à sa seule discrétion:

- fournir gratuitement à l'acheteur en départ usine des produits de même nature et quantité que ceux résultants défectueux ou non conformes à ce qui avait été établi, après en avoir obtenu le rendement pour vérification. Tout éventuel remplacement effectué sans délai par le vendeur ne peut pas être considérée comme une reconnaissance implicite des défauts contestés: la dite reconnaissance devra toujours être explicite et conséquente au contrôle de la part du vendeur des produits contestés. Si le vendeur, après vérification, ne reconnaît pas de défaut qui lui soit imputable sur les produits, il facturera les produits envoyés en substitution;
- émettre une note de crédit en faveur de l'acheteur pour un montant correspondant à la valeur des produits défectueux. Dans les deux cas, le vendeur a le droit à la restitution des produits défectueux, qui deviennent de sa propriété.

### 8. Limitation de responsabilité du vendeur

Sauf intention ou faute grave du vendeur, l'éventuelle compensation de tout dommage à l'acheteur ne pourra en aucun cas dépasser le prix facturé des produits contestés.

### 9. Paiement

Les paiements et toute autre somme due à quelque titre que ce soit au vendeur, s'entendent nets à son domicile. Tout retard ou irrégularité dans le paiement donne au vendeur le droit de suspendre les livraisons ou de résilier les contrats en cours, même s'ils ne sont pas relatifs aux paiements en question, ainsi que le droit à l'indemnisation des dommages. Le vendeur a également droit, à partir de la date d'échéance du paiement, aux intérêts de retard dans la mesure établie à l'article 5 du décret législatif italien 9 Octobre 2002 n° 231. Le retard de paiement donne également au vendeur le droit d'exclure la garantie tout au long de la période durant laquelle le retard persiste.

### 10. Réserve de propriété

Les produits livrés restent sous la propriété du vendeur jusqu'à complet paiement du prix.

### 11. Loi applicable et juridiction

Tous les contrats disciplinés par ces conditions générales présentes sont régies par la loi italienne. Tout litige dérivant de, ou relié à des contrats auxquels s'appliquent ces conditions générales est sous la compétence exclusive de la juridiction du vendeur: ce dernier aura toutefois la faculté d'agir dans la juridiction de l'acheteur.





GRAFFIO®

Sign and design  
your lifestyle



**GRAFFIO** is designed by  
NUOVA OSMO S.r.l.

Via Dr. Bellosta, 46  
28017 S. Maurizio D'Opaglio (NO)  
ITALY  
0039 0322 950272

[www.graffio.no.it](http://www.graffio.no.it)  
[info@graffio.no.it](mailto:info@graffio.no.it)